

**Talc and soapstone: their mining, milling, products and uses, by Raymond B. Ladoo.**

Ladoo, Raymond Bardeen, 1893-  
Washington, Govt. print. off., 1923.

<https://hdl.handle.net/2027/uiug.30112104112039>

# HathiTrust



[www.hathitrust.org](http://www.hathitrust.org)

**Public Domain, Google-digitized**

[http://www.hathitrust.org/access\\_use#pd-google](http://www.hathitrust.org/access_use#pd-google)

We have determined this work to be in the public domain, meaning that it is not subject to copyright. Users are free to copy, use, and redistribute the work in part or in whole. It is possible that current copyright holders, heirs or the estate of the authors of individual portions of the work, such as illustrations or photographs, assert copyrights over these portions. Depending on the nature of subsequent use that is made, additional rights may need to be obtained independently of anything we can address. The digital images and OCR of this work were produced by Google, Inc. (indicated by a watermark on each page in the PageTurner). Google requests that the images and OCR not be re-hosted, redistributed or used commercially. The images are provided for educational, scholarly, non-commercial purposes.

DEPARTMENT OF THE INTERIOR

ALBERT B. FALL, SECRETARY

BUREAU OF MINES

H. FOSTER BAIN, DIRECTOR

*Stacks*  
25524  
85  
see

# TALC AND SOAPSTONE

## THEIR MINING, MILLING, PRODUCTS AND USES

BY

RAYMOND B. LADOO



WASHINGTON  
GOVERNMENT PRINTING OFFICE

1923

UNIVERSITY OF ILLINOIS-URBANA



3 0112 104112039

Generated at University of Michigan on 2023-02-13 11:27 GMT / https://hdl.handle.net/2027/ulug.30112104112039  
Public Domain, Google-digitized / http://www.hathitrust.org/access\_use#pd-gooqle

The Bureau of Mines, in carrying out one of the provisions of its organic act—to disseminate information concerning investigations made—prints a limited free edition of each of its publications.

When this edition is exhausted, copies may be obtained at cost price only through the Superintendent of Documents, Government Printing Office, Washington, D. C.

The Superintendent of Documents *is not an official of the Bureau of Mines*. His is an entirely separate office and he should be addressed:

SUPERINTENDENT OF DOCUMENTS,  
*Government Printing Office,*  
*Washington, D. C.*

The general law under which publications are distributed prohibits the giving of more than one copy of a publication to one person. The price of this publication is 25 cents.

Persons desiring for lecture purposes the use, free of charge, of lantern slides of the illustrations in this publication, should make request of the Director of the Bureau of Mines, Washington, D. C.

*First edition, December, 1922.*

622.09  
Un 32b  
no. 213-17  
cop. 2

Remote  
Storage

CONTENTS.

	Page.
Mineralogy and characteristics.....	1
Origin and geological occurrence.....	4
Geological distribution.....	6
World production.....	7
United States.....	8
Vermont.....	8
New York.....	8
Virginia.....	8
California.....	9
Georgia.....	9
North Carolina.....	9
Other States.....	9
France.....	9
Italy.....	10
Canada.....	10
Austria-Hungary.....	10
Spain.....	10
Germany.....	11
India.....	11
British South Africa.....	11
Brazil.....	11
China.....	11
Norway.....	12
Japan.....	12
British Isles.....	12
Philippines.....	12
Colombia.....	12
Other countries.....	12
Effect of transportation on geographical distribution.....	13
Factors influencing new talc-mining ventures.....	14
Markets and prices.....	14
Size and location of deposit.....	15
Present mill capacity.....	15
Mining and milling methods.....	15
Cost accounting.....	16
Royalties.....	16
Prospecting and development.....	17
Quarrying and milling of slab soapstone.....	18
Mining methods.....	19
Openings to surface.....	19
Drifting, crosscutting, and raising.....	19
Stoping.....	20

590113

III

Generated at University of Michigan on 2023-02-13 11:27 GMT / https://hdl.handle.net/2027/uidug.30112104112039  
Public Domain, Google-digitized / http://www.hathitrust.org/access\_use#pd-goo

	Page.
<b>Mining methods—Continued.</b>	
Timbering.....	22
Drilling and shooting.....	22
Loading.....	23
Haulage, hoisting, and signaling.....	24
Drainage.....	25
Ventilation.....	26
Lighting.....	26
Surface arrangements.....	26
Mining plant.....	28
Transportation to mill.....	29
<b>Milling</b> .....	31
History.....	31
Need for proper methods.....	32
Factors in the choice of milling methods.....	32
Physical characteristics.....	33
Availability and cost of power.....	33
Size of output and grades of product.....	34
Relation between first costs and final costs.....	34
Quality, quantity, and cost of labor.....	34
Location and design of mill.....	35
Unloading, sorting, and crude storage.....	35
Freezing in bins.....	37
Dryers.....	37
Examples of present practice.....	38
Best methods of handling wet fines.....	40
Primary or coarse crushing.....	41
Secondary or intermediate crushing.....	42
Fine grinding.....	44
Factors in fine grinding.....	44
Buhr mill.....	44
Vertical emery mill.....	45
Disintegrators, pulverizers, and hammer mills.....	45
The Raymond roller mill.....	46
The Fuller-Lehigh mill.....	47
Tube mills.....	47
The dump cylinder.....	47
The continuous tube mill.....	48
The short tube mill.....	50
The Hardinge mill.....	50
Screening.....	50
Grizzlies and trommels.....	50
Impact and vibrated screens.....	51
Bolting reels.....	51
Air separation.....	52
Raymond air-separation system.....	52
Very fine separation.....	53
Theory of air separation.....	54
Applications of air separation.....	54
Removing impurities.....	55
Emerick air separator.....	55
Construction and principle.....	55
Adaptability.....	57

	Page.
<b>Milling—Continued.</b>	
Wet grinding.....	57
<b>Bagging</b> .....	59
Bagging by hand.....	59
Talc packers.....	59
Factors in the use of bagging machines.....	59
Storage.....	80
Shipment.....	62
<b>Accessory machinery</b> .....	63
Elevators and conveyors.....	63
Ore feeders.....	63
Magnetic pulleys.....	63
Power plant.....	63
Manufacture of pencils and crayons.....	64
<b>Uses of talc and soapstone</b> .....	65
List of uses.....	66
Uses of powdered talc and soapstone.....	66
Uses of massive talc and soapstone.....	69
Factors controlling use.....	70
Utilization of talc.....	71
Paper making.....	71
Types of paper.....	72
Influence of talc.....	73
Use of talc in Scandinavia.....	73
Advantages of talc.....	74
Pottery.....	74
Paints.....	76
Talc in fire-resistant paint.....	77
Glass.....	79
Lime plasters.....	80
Lava gas-tips and electrical insulation.....	80
The testing of ground talc.....	82
Physical tests.....	82
Size of grain.....	82
Shape of grain.....	83
Hardness.....	83
Color.....	84
Slip.....	84
Specific gravity.....	84
Grit—size, nature, and percentage of oversize.....	85
Absorptive power.....	85
Behavior under heat.....	86
Chemical tests.....	86
Importance of standard tests.....	86
Commercial grades of talc.....	87
Representative mines and mills.....	89
Introduction.....	89
<b>Talc mining in Vermont</b> .....	89
Relative importance of the Vermont district.....	89
Location of deposits.....	89
Mode of occurrence.....	90

	Page.
Talc mining in Vermont—Continued.	
Description of more important plants.....	91
Vermont Talc Co., Chester, Vt.....	91
Eastern Talc Co., Rochester and East Granville, Vt.....	93
Mining method.....	93
Milling.....	95
East Granville operations.....	95
Magnesia Talc Co., Waterbury, Vt.....	95
Mining method.....	96
Milling.....	96
American Milling Co., Johnson, Vt.....	98
Mining method.....	98
Milling.....	99
Talc mining in New York.....	100
Importance and distribution of talc in New York.....	100
Mode of occurrence.....	100
Description of individual mines and plants.....	102
St. Lawrence Talc Co. (Carbola Chemical Co.), Natural Bridge, N. Y.....	102
Mining.....	102
Milling.....	103
Uniform Fibrous Talc Co., Talcville, N. Y.....	104
Milling.....	105
International Pulp Co., Gouverneur, N. Y.....	106
Mining.....	106
Milling.....	107
W. H. Loomis Talc Corporation, Gouverneur, N. Y.....	108
Talc in Massachusetts.....	109
Foliated Talc Co. (International Talc Co.), Rowe, Mass.....	110
Mining method.....	110
Milling.....	111
Power.....	111
High-grade talc and the California talc industry.....	111
High-grade talc defined.....	111
Domestic production and imports.....	112
Essential qualities.....	112
California talc industry.....	113
The Inyo Talc Co., Keeler, Calif.....	114
The Pacific Coast Talc Co., Silver Lake, Calif.....	115
Other companies.....	116
The Southern talc industry.....	117
Description of individual mines and plants.....	118
Talc Products Co., Glendon, N. C.....	118
Milling.....	119
The Biltmore Talc Co., Biltmore, N. C.....	121
Milling.....	121
Flow sheets of other mills.....	122
Mining and Milling at Madoc, Ontario, Canada.....	122
Mining.....	122
Milling.....	124
Talc in British South Africa.....	125
The Verdite mine.....	126
Publications on nonmetallic mineral technology.....	127
Index.....	129

## ILLUSTRATIONS.

	Page.
<b>PLATE I. A</b> , Top of mill bins showing mine cars ready to be dumped at the <b>Magnesia Talc Co.</b> , Waterbury, Vt.; <b>B</b> , Mill and incline from mine at the <b>Uniform Fibrous Talc Co.</b> , Talcville, N. Y.-----	30
<b>II. A</b> , Talc mill of the <b>Eastern Talc Co.</b> , near Rochester, Vt., showing incline plane from mine track; <b>B</b> , Truck and car for incline cableway shown in Plate II, <b>A</b> -----	31
<b>III. A</b> , Feed spout for belt conveyor at <b>Magnesia Talc Co.</b> , Waterbury, Conn.; <b>B</b> , Belt conveyor reclaiming crude talc at the old mill of the <b>American Mineral Co.</b> , Johnson, Vt.-----	30
<b>IV. A</b> , Raymond pulverizer equipped with automatic throw-out attachment; <b>B</b> , Hammer mill-----	31
<b>V. A</b> , Vertical emery mill; <b>B</b> , Underrunner buhr mill-----	44
<b>VI. Fuller-Lehigh mill</b> -----	45
<b>VII. A</b> , Newaygo screen; <b>B</b> , The Tyler Hummer screen-----	44
<b>VIII. A</b> , Rotary crusher; <b>B</b> , Base casting of Raymond roller mill; <b>C</b> , Raymond cyclone, tubular, dust collector-----	45
<b>IX. Raymond four-roller, low-side mill, with exhaust fan and cyclone dust collector</b> -----	52
<b>X. A</b> , Raymond mill, vacuum separator; <b>B</b> , Section of Raymond high-side roller mill and separator-----	53
<b>XI. Howes talc packer</b> -----	52
<b>XII. Bates valve bagging machine</b> -----	53
<b>XIII. Underground view showing method of tunneling of the American Mineral Co.</b> , Johnson, Vt.-----	98
<b>XIV. A</b> , Old and new shaft houses of the <b>American Mineral Co.</b> , Johnson, Vt.; <b>B</b> , Rock house of the <b>W. H. Loomis Talc Corporation</b> , Gouverneur, N. Y.; <b>C</b> , Open cut of the <b>Talc Products Co.</b> , Glendon, N. C.-----	99
<b>XV. A</b> , Front view of the mill of the <b>Inyo Talc Co.</b> , Keeler, Calif.; <b>B</b> , Main shaft of the <b>Pacific Coast Talc Co.</b> , Silver Lake, Calif.-----	98
<b>FIGURE 1. Cross section of the Raymond roller mill</b> -----	46
<b>2. Curve showing the amount of total grinding accomplished at different points in a 6 by 26 inch tube mill pulverizing talc</b> -----	49
<b>3. Sectional view of Emerick air separator, showing direction of air currents</b> -----	56
<b>4. Flow sheet of proposed talc mill using wet grinding</b> -----	58
<b>5. Flow sheet of mill of the Vermont Talc Co.</b> , Chester, Vt.-----	92
<b>6. Flow sheet of mills No. 2 and No. 3, Eastern Talc Co.</b> , Rochester, Vt.-----	94
<b>7. Flow sheet of mill of the Magnesia Talc Co.</b> , Waterbury, Vt.-----	97
<b>8. Flow sheet of mill of the St. Lawrence Talc Co.</b> , Natural Bridge, N. Y.-----	104
<b>9. Flow sheet of mill of the Uniform Fibrous Talc Co.</b> , Talcville, N. Y.-----	105
<b>10. Flow sheet of No. 6 mill of the International Pulp Co.</b> , Gouverneur, N. Y.-----	107
<b>11. Flow sheet of No. 3 mill of the International Pulp Co.</b> , Gouverneur, N. Y.-----	108
<b>12. Flow sheet of the W. H. Loomis Talc Corporation</b> , Emeryville, N. Y.-----	109



	Page.
FIGURE 13. Flow sheet of mill of the Foliated Talc Co., Rowe, Mass.....	110
14. Flow sheet of mill of the Inyo Talc Co., Keeler, Calif.....	115
15. Flow sheet of mill of the Pacific Coast Talc Co., Silver Lake, Calif.....	116
16. Flow sheet of old mill of the Talc Products Co., Glendon, N. C..	119
17. Flow sheet of mill of the Biltmore Talc Co., Biltmore, N. C....	120
18. Flow sheet of mill of the Georgia Talc Co., Chatsworth, Ga....	120
19. Flow sheet of mill of the Chattanooga Talc Co., Chatta- nooga, Tenn.....	120
20. Flow sheet of mill of the Cohutta Talc Co., Chatsworth, Ga....	121
21. Flow sheet of mill of the D. M. Steward Co., Chatta- nooga, Tenn.....	121
22. Sketch of vertical section along drift in mine of George H. Gillespie Co., Madoc, Ontario.....	123
23. Flow sheet of mill of the George H. Gillespie Co., Madoc, Ontario.....	124

# TALC AND SOAPSTONE—THEIR MINING, MILLING, PRODUCTS, AND USES.

By RAYMOND B. LADDO.

## MINERALOGY AND CHARACTERISTICS.

Talc is a hydrous magnesium silicate having the chemical formula  $H_2Mg_3(SiO_3)_4$ ; it is often called steatite, soapstone or potstone, and by the trade names talc clay, agalite, asbestine, and verdolite. The term talc may be used to include all forms of the pure mineral, whereas steatite denotes particularly the massive, compact variety, and soapstone the impure, massive form that often contains only 50 per cent of talc. Merrill<sup>1</sup> says:

The name soapstone is given to dark-gray and greenish talcose rocks, which are soft enough to be readily cut with a knife, and which have a pronounced soapy or greasy feeling; hence the name. Such rocks are commonly stated in textbooks to be compact forms of steatite, or talc, but as the writer has elsewhere pointed out, and as shown by the analyses here given, few of them are even approximately pure forms of this mineral, but all contain varying proportions of chlorite, mica, and tremolite, together with perhaps unaltered residuals of pyroxene, granules of iron ore, iron pyrites, quartz, and, in seams and veins, calcite and magnesian carbonates.

When pure, talc is soft, having a hardness of 1, but when impure or when it grades into its varieties, the hardness increases to 3 or 4. Talc ranges in color from pure white and silvery white through gray, green, apple green, gray green to dark green, also yellow, brown, or reddish when impure. It is rarely, if ever, found in well-formed crystals, but often occurs in foliated plates or in fibrous aggregates. It is commonly compact or massive or in fine granular aggregates. Several analyses of talc from different regions are given in Table 1.

Talc has several varieties, the most important of which is Rensselaerite. This variety, found in a small area near Gouverneur, St. Lawrence County, N. Y., is a hard, fibrous, waxlike mineral having the same chemical composition as talc, but lacking its softness and its peculiar greasy feel. Its hardness and its peculiar fibrous form, even when ground, have made its grinding and sepa-

<sup>1</sup> Merrill, G. P., *The nonmetallic minerals*, 2d ed., New York, 1910, pp. 208-209.

TABLE 1.—*Analyses of talc.*

	1 a	2 b	3 c	4 d	5 e	6 f	7 g
SiO <sub>2</sub> .....	61.06	60.21	62.10	60.20	61.51	63.50	64.53
Al <sub>2</sub> O <sub>3</sub> .....	3.63	4.23	.....	1.25	0.83	.....	29.40
Fe <sub>2</sub> O <sub>3</sub> .....	.....	.00	.....	2.50	.....	.....	.....
FeO.....	2.89	4.12	1.30	.00	0.12	.....	0.67
MnO.....	.....	.28	2.15	.....	.....	.....	.....
MgO.....	28.60	27.90	32.40	27.98	30.93	31.70	Tr.
CaO.....	Tr.	.00	.....	2.60	3.70	.....	Tr.
Na <sub>2</sub> O.....	.....	.....	.....	.....	.....	.....	0.28
H <sub>2</sub> O.....	3.92	4.90	2.05	5.70	2.84	4.80	5.45
	100.10	101.77	100.00	100.23	99.93	100.00	100.33

a Waterville, Vt. Analysis by Massachusetts Inst. of Tech.

b Moretown, Vt. Analysis by Vermont State Geol. Survey.

c Gouverneur, N. Y., fibrous talc. Analysis by Sperry, Dana's System of Min., 6th ed., 1911, p. 679.

d Sheep Creek, near Silver Lake, San Bernardino County, Calif. Analysis by R. H. Percy.

e St. Gothard, Switzerland. Fibrous talc. Analysis by Scheerer, Dana's System of Min., 6th ed., 1911, p. 679.

f Theoretical composition of pure talc.

g Glendon, N. C., pyrophyllite. Analysis by Chas. Baskerville, Univ. of North Carolina.

ration a separate problem. In addition to the varieties of talc and soapstone, the mineral pyrophyllite or agalmatolite, a hydrous silicate of alumina, with the formula  $H_2Al_2(SiO_3)_4$ , is also mined and sold as talc. It resembles talc in color, feel, luster, and structure, and may be successfully substituted for true talc for most uses. In this paper it will be considered as one of the commercial forms of talc. The eleventh edition of the Encyclopedia Britannica says of the history of talc:

The "steatites" of Pliny was a stone resembling fat, but otherwise undescribed. Being easily cut, steatite has always been a favorite material with the carver; it was used for Egyptian scarabs and other amulets, which were usually coated with a blue, vitreous glaze; and it was employed for Assyrian cylinder seals and other ancient signets. By the Chinese, steatite is largely used for ornamental carvings, but many of their soapstone figures are wrought in a compact pyrophyllite which is essentially different from talc. The name agalmatolite is often applied to the material of these figures, and was suggested by M. H. Klaproth from the Greek agalma (an image). Pagodite is an old name for Chinese figure stone. Ancient steatite carvings are found among the ruins of Rhodesia.

Steatite and talc schists are widely distributed, and have occasionally been used as building stones. When first raised the stone is soft, but hardens on exposure. Soapstone from Gudbrandsdal is used in the cathedral of Trondhjem in Norway. Veins of steatite occur in the serpentine of the Lizard district in Cornwall, and the mineral was used under the name of soap rock in the manufacture of old Worcester porcelain.

Pure talc is a distinct mineral species with a definite chemical formula; nevertheless, pure talcs from different districts vary widely in physical and chemical properties; when they contain even slight impurities, the differences are much greater. Specimens illustrating a dozen different types have been found in a single mine. By careful mining and milling these different types may be separated into a few uniform grades. In addition to inherent differences in crude

talcs, further differences in ground talcs are developed by different methods of grinding and separating. Failure to recognize these differences commercially has often led to the condemning of talc in general for some uses, on the strength of tests on a single grade. On the other hand, some minerals constituting mineralogic impurities are often ground with talc and are in no way detrimental if the finished product is properly prepared. Thus the grinding of serpentine with talc may result in a product as suitable for many uses as is pure talc.

Since talc and soapstone have neither a fixed composition nor constant chemical and physical properties, as have the metals, any discussion of origin, uses, and substitutes must consider variations in grade—both inherent differences and those produced by grinding—and also therefore variations in value and in suitability for different uses.

Although the uses of talc and soapstone are many and varied, few of them can justly be considered essential, in the sense that no substitutes can be used, but several are of great importance. Massive, close-grained talc, free from iron and grit, is cut into blanks and baked, forming the material, used for gas tips and electrical insulation, commercially known as lava. The hardness of lava, its resistance to heat, acids, and alkalis, and its great dielectric strength make it very useful for electric insulation, and no satisfactory substitute for it has been found. The widest use of talc is in the powdered form. The value of ground talc depends upon color (whiteness), uniformity, fineness of grain, freedom from grit, "slip," and sometimes freedom from lime. White talc, free from grit and iron, and low in lime, ground to about 200-mesh, is used largely as a filler for paper, rubber, and paint. Ground talc and soapstone are used for foundry facings, either alone or mixed with graphite. A coarser grade of talc is used in the manufacture of asphalt-coated roofing felts and papers, both as a filler and as a surfacing. The highest grade of ground talc is used as toilet powder, whiteness, fineness of grain, freedom from grit and lime, and a good "slip" being essential. Ground talc is also used in dressing and coating cloth, in making soap, rope, twine, pipe-covering compounds, heavy lubricants, and polishes. Massive varieties of talc, pyrophyllite, and high grades of soapstone are cut into slate pencils and steel-workers' crayons. French chalk or tailors' chalk is a soft, massive variety of talc. In China, Japan, and India, massive talc is carved into grotesque images and other forms and is often sold as imitation jade.

Soapstone is usually cut into slabs from 1 inch to 2 inches in thickness and sold as griddles, footwarmers, and fireless-cooker stones, or fabricated into laundry sinks and tubs, laboratory-table tops, hoods, tanks, and sinks, electric switchboards, and other uses

in which the properties of resistance to heat, acids, and alkalis, and electricity are essential. For a more complete discussion of its utilization, see pages 69–70.

### ORIGIN AND GEOLOGICAL OCCURRENCE.

Talc is usually a secondary mineral resulting from the alteration of other magnesian silicates or, occasionally, carbonates. The original rocks may have been either sedimentary or igneous, types of each being common. Tremolite, pyroxenite, serpentine, and dolomite have all been recognized as constituting the original source of talc. In many deposits the alteration is not complete and the talc as mined and ground often contains some of these original constituents.

The modes of occurrence of talc have been briefly described by Diller<sup>2</sup> as follows:

There are three distinct modes of occurrence of talc—(1) as an altered sedimentary rock; (2) as an altered igneous rock; (3) as a definite vein. The first two modes of occurrence are of commercial importance; the third mode though yielding the purest talc is of little commercial significance.

Distinct as these three modes of occurrence appear to be, yet on account of the fact that talc is associated with highly disturbed and altered rocks, it is not always easy to determine the mode of occurrence, especially when the talc is not associated with belts of limestone. However, as the most important bodies of commercial talc are either within or near belts of limestone with which they are approximately parallel, it seems probable that the greater portion of commercial talc is derived from the alteration of sedimentary rocks.

*Talc as an altered sedimentary rock.*—This mode of occurrence is best illustrated in the Gouverneur region of New York, where the origin of the material has been studied in detail by C. H. Smyth, jr.,<sup>3</sup> and more recently by D. H. Newland,<sup>4</sup> from whose account the following information is abstracted:

The rocks belong to the same general classes as compose the central Adirondack region described in other reports. "The talc deposits are associated immediately with crystalline limestone and schists of Grenville age." Three belts are mentioned. One, the largest, begins in Antwerp, Jefferson County, and crosses the towns of Gouverneur and De Kalb in St. Lawrence County, and has important marble quarries at Gouverneur. "The second belt, 12 miles long and from 1 to 3 miles wide, is found a few miles to the east, in the towns of Fowler and Edwards. It is this area that contains the fibrous deposits. The third belt, to the south and east of the latter and lying across the St. Lawrence and Lewis County line, includes the Natural Bridge talc occurrence that has been recently under development.

"The limestones are bordered by members of the Adirondack gneisses, some of which are light in color and have the composition and appearance of slightly modified granites and diorites. A very prominent member in the stretch between Gouverneur and the talc district is a dark hornblende variety, which

<sup>2</sup> Diller, J. S., Talc and soapstone in 1912: U. S. Geol. Survey, Mineral Resources of the United States, pt. 2, pp. 1143–1145.

<sup>3</sup> Smyth, C. H., jr., Report on four townships in St. Lawrence and Jefferson Counties, New York: State Mus. Rept. 47, 1894, pp. 491–515. Also Report on talc industry of St. Lawrence County, New York: State Mus. Rept. 49–2, 1898, pp. 661–671.

<sup>4</sup> Newland, D. H., The mining and quarry industry of the State of New York; Production of 1911: Bull. New York State Education Dept., 522, 1912, pp. 91–100.

is usually well laminated and garnetiferous and is injected by light red granite. In places the granite forms a branching network that incloses the darker rock in its meshes, producing a mosaic pattern. These granite injections are no doubt offshoots of some of the larger bodies of that rock, while the darker gneiss may belong to the sedimentary series. Of the general relations of the gneiss group it can be said that the igneous types are apparently the youngest and are all later than the limestones. It is not clearly demonstrated as yet whether any of the gneisses in the region are older than the Grenville.

"The talc deposits occur along minor belts within the Grenville limestones and schists. They are locally called veins and have been described as such by some writers, though they have nothing in common with mineral veins, being layers or beds included within the limestones. They have the same strike and dip as the latter and show a fair degree of regularity and persistence. In thickness they range from seams of a few inches up to 50 feet or more. The dip is uniformly to the northwest at angles that vary usually between the limits of 30 and 60°.

"The associated schists are mainly composed of tremolite, but in some places carry considerable quartz. They are singularly free from other minerals. The tremolite is white or light gray in color and is usually developed in finely fibrous individuals, which when felted form a compact and tough rock. The pink variety, known as hexagonite, is of limited occurrence. Bands and irregular masses of the tremolite occur within the talc deposits, and the immediate walls generally consist of the schist, the border being marked by alternating layers of talc and schist.

"The association is suggestive of the derivation of the talc, which has been the subject of study by C. H. Smyth, jr.<sup>5</sup> The tremolite is no doubt the parent mineral. As explained by Professor Smyth, the limestones were originally impure calcareous sediments and by metamorphic influences have taken on a crystalline character and become impregnated with silicates. Certain limestone beds seem to have contained sufficient magnesia and silica to permit their complete transformation to tremolite, forming a tremolite schist, while other layers, with a predominance of lime, have undergone a partial change, showing scattered crystals and aggregates of silicates within the limestone. The subsequent change of tremolite to talc is the result of weathering and takes place through the agency of ground waters holding carbon dioxide. The alteration may be formulated chemically as follows:  $\text{CaMg}_3\text{Si}_4\text{O}_{12} + \text{H}_2\text{O} + \text{CO}_2 = \text{H}_2\text{Mg}_3\text{Si}_4\text{O}_{12} + \text{CaCO}_3$ . The change is accompanied by an increase in volume of talc and calcite, amounting to 25.61 per cent, though if the talc above is considered there is a decrease of 0.83 per cent, as compared with the tremolite. There is little or no calcite in the talc, so that it probably has been removed with the progress of the alteration.

"The talc is really a pseudomorph after tremolite, and it is due to this that it possesses a fibrous character. Microscopic examination of specimens from almost any of the mines shows a little residual tremolite in the centers of the fiber aggregates, and in some samples there is a very considerable proportion of unaltered mineral. Foliated talc accompanies the fibrous variety, being more abundant apparently the further the process of alteration has gone. It is, of course, a separate development, deposited by the circulating waters which have taken the materials of the schists into solution.

"The view that the tremolite has been formed by metamorphism from the ingredients of the limestones without addition of material from other sources

<sup>5</sup> Smyth, C. H., jr., work cited.

is perhaps the least conclusive part of the explanation. This entails a rather unusual chemical composition that is hardly in conformity with the character of the limestones in the district. As a rule they are not particularly siliceous or impure. An alternative to this view which would seem equally probable in the circumstances may be found in the introduction of silica and magnesia along certain beds by underground circulation after the limestones were formed."

The high-grade talc of western North Carolina occurs in essentially the same way as that of New York. Arthur Keith, of the United States Geological Survey, has described it in the Nantahala folio.<sup>6</sup> The talc bodies are lenticular, ranging in size from a mere fiber up to 50 feet in thickness and several hundred feet in length. It is closely associated with more or less crystalline limestone and is in general more compact than that of New York, so as to be suitable for cutting into various shapes.

Although many lenses of talc have been found in the limestone belt throughout a distance of nearly 50 miles, the lenses are for the most part small, and but few mines have been developed.

*Talc as an altered igneous rock.*—Talc derived from the alteration of basic igneous masses has been found at many places among the older crystalline rocks from New England to Georgia. Keith has mapped and described such occurrences in North Carolina in the Mount Mitchell, Nantahala, and other folios. The talc is commonly associated with soapstone. In most cases there were found in addition to talc a number of other silicates containing magnesia, such as chlorite and varieties of hornblende. As a rule the talc is equaled or exceeded in quantity by the other silicates. The purer soapstone and talc are usually found on the borders of the mass.

Although the available amount of talc of this class, as shown by Keith in the folios referred to above, is considerable, but little is now produced.

One of the most notable of this class of occurrences is the talc mined in the vicinity of Chatsworth, Ga., where, according to Veatch,<sup>7</sup> the talc results from the alternative of peridotite, which has been intruded into quartzite and quartz schist.

In addition to the type occurrences described above may be noted the deposit at Madoc, Ontario, Canada, worked by the G. H. Gillespie Co. (Ltd.). This talc is thought to have been derived from a dolomite member of a series of gneisses and schists. The intimate admixture of dolomite with the talc in places here seems to suggest this theory. (See p. 122, G. H. Gillespie mine.)

### GEOGRAPHICAL DISTRIBUTION.

Talc and soapstone, with pyrophyllite—usually sold as talc—are widely distributed over the earth. Deposits are known in nearly every country, but production on a commercial scale has been confined mostly to the countries having highest industrial development. Of the total for the world, the United States produces about 65 per cent, France 13.4 per cent, Italy 7.4 per cent, Germany and Austria 5.4 per cent, and Canada 4.7 per cent. As soapstone, used in slabs and in such fabricated articles as sinks and tubs, is produced in important quantities in the United States only, this discussion will be

<sup>6</sup> Keith, Arthur, Nantahala folio (No. 143) : U. S. Geol. Survey, Geol. Atlas U. S., 1907.

<sup>7</sup> Veatch, Otto, Mineral resources of Georgia, 1910, p. 187.

confined largely to various grades of ground and massive talc. It should be noted, however, that the American aborigines and the natives of many other countries, such as India and Brazil, made, and still make, use of massive soapstone in the manufacture of pots and kettles.

Although the most valuable grade of ground talc is that used for toilet purposes, by far the largest output is of the lower grades used in the manufacture of paper, rubber, paint, prepared roofing, and other wares. As these grades of talc will not stand high transportation charges, the greatest production is from the countries and districts that have best developed the industrial uses. The market for the highest grades of talc is limited and therefore the nonindustrial countries produce only high-grade talc and that in small quantities.

In the United States, Canada, Germany, and Austria many uses have been found for the lower grades. In France and Italy the chief product shipped is high-grade talc for toilet purposes and massive talc for the manufacture of lava, but some use is made of the lower grades. In most of the other producing countries there is little or no market for anything but the highest grades. Thus India, Brazil, Japan, and Spain, though they possess many known deposits, produce only small quantities. High-grade massive talc suitable for the manufacture of lava has not been found in the United States in quantities large enough to satisfy domestic needs, and the best grades are imported from Italy, Germany, Austria, India, and France.

#### WORLD PRODUCTION.

The accompanying table indicates the approximate distribution of production.

TABLE 2.—*World's production of talc and soapstone.*

[Short tons.]

Country.	1912	1913	1916	1917	1918	Per cent in 1918.
United States <sup>a</sup> .....	159, 270	175, 883	212, 961	218, 848	191, 477	60.4
France <sup>b</sup> .....	60, 629	66, 332	(c)	d 45, 000	63, 459	20.0
Italy <sup>c</sup> .....	15, 800	23, 530	28, 586	24, 100	19, 146	6.0
Canada <sup>e</sup> .....	8, 270	12, 250	13, 104	15, 803	18, 146	5.7
Austria <sup>e</sup> .....	(c)	(c)	(c)	d 12, 000	d 12, 000	3.8
Norway <sup>e</sup> .....	885	1, 653	6, 063	d 5, 000	3, 023	0.9
Spain <sup>f</sup> .....	(c)	(c)	1, 062	3, 803	3, 328	1.1
Germany (Bavaria) <sup>f</sup> .....	3, 551	(c)	(c)	d 3, 500	3, 000	0.9
British South Africa <sup>e</sup> .....	(c)	(c)	132	785	608	0.2
India <sup>e</sup> .....	882	1, 350	1, 010	7, 954	d 2, 772	0.8
Total production.....					317, 003	99.8

<sup>a</sup> Talc and soapstone.

<sup>b</sup> Talc, soapstone, and asbestos.

<sup>c</sup> Statistics unavailable.

<sup>d</sup> Statistics unavailable. Figures represent producing capacity estimated to obtain approximate world production.

<sup>e</sup> Talc.

<sup>f</sup> Soapstone.



For convenience of discussion talc and soapstone will be divided into the following grades: A, toilet-grade talc; B, second or industrial grade talc; C, lava or cutting-grade talc; D, fabricating-grade soapstone; E, grinding-grade soapstone. Letters used in parenthesis indicate grades of secondary importance.

#### UNITED STATES.

The production of talc in the United States in 1919 was divided as follows:

TABLE 3.—*Production of talc in United States, 1919.*

State.	Quantity (short tons).	Value.	Average value per ton.
California .....	9,837	\$147,470	\$14.99
New York .....	62,495	750,765	12.01
North Carolina .....	2,602	76,158	29.27
Vermont .....	78,661	665,652	8.46
Virginia, Georgia, Maryland, Massachusetts, New Jersey, Pennsylvania, and Washington .....	14,744	182,467	12.38
	168,339	1,822,512	10.83

The entire production of soapstone in 1919, 16,504 tons, valued at \$530,163, came from Virginia.

#### VERMONT, GRADES B, (A), (C), (D).

The talc-producing centers at present are Rochester, East Granville, Waterbury, Johnson, Chester, and Windham. Soapstone is produced only at Chester. Many other deposits that have been worked are now idle. Vermont has the largest known reserves of any producing State, over 7,000,000 tons being reported from only two companies.

#### NEW YORK, GRADES B, (A).

In New York the most important producing centers are around Gouverneur, St. Lawrence County, and Natural Bridge, Jefferson County. Most New York talcs have a fibrous structure and are often sold as "asbestine."

#### VIRGINIA, GRADES D, E, (B).

The district producing the most massive soapstone in the United States is in Nelson and Albemarle Counties, Va. Ground soapstone is being produced in Fairfax and Franklin Counties. Important but undeveloped deposits of soapstone are also found in Campbell, Bedford, Amelia, Grayson, Carroll, and several other counties. Talc in commercial quantities is found chiefly in Fairfax County.

## CALIFORNIA, GRADES A, B.

A very high grade of talc, suitable for toilet purposes, has been mined in California at Lindsay, Tulare County; Zabriskie, Keeler, and Tecopa, Inyo County; and Riggs, Avawatz, and Silver Lake, San Bernardino County. Talc not suitable for the toilet trade is used in paper and tile.

## GEORGIA, GRADES B, C.

Talc suitable both for cutting into pencils and lava blanks and for grinding is mined near Chatsworth, Murray County, Ga. Some mining has been done near Mineral Bluff, Fannin County, and near Ball Ground and Holly Springs, Cherokee County.

## NORTH CAROLINA, GRADES B, C, (A), (D).

Both talc and pyrophyllite are mined in North Carolina. Pyrophyllite, which is ground and cut into pencils, is mined at Glendon and Hemp, Moore County. Talc that is ground or cut into pencils and lava blanks has been mined at Kinsey and Marble, Cherokee County; at Marshall, Madison County; Candler, Buncombe County; Nantahala and Hewitts, Swain County; and Beta, Jackson County. Unimportant deposits of massive soapstone occur at Piney Creek, Alleghany County.

## OTHER STATES.

Some talcs, grades B, C, and soapstone, D, are mined in Harford, Cecil, and Howard Counties, Md. Several deposits of talc B have been worked at Easton, Pa., Phillipsburg, N. J., and Zoar and Rowe, Mass. A high-grade massive talc is being mined near Mondovi, Lincoln County, Wash. A deposit of fibrous talc of commercial size has been reported in the Laramie hills, near Wheatland, Wyo. A deposit of talc of medium to high grade has been reported near Dillon, Mont. Massive talc, of lava grade, has been mined near Talladega, Ala. There are large deposits of soapstone near Benton, Saline County, Ark., but distance from a railroad has so far prevented its commercial exploitation. Soapstone deposits have been worked at Manville, R. I., and Francestown, N. H.

## FRANCE.

The deposits noted here produce grades A, B, and C. Eighty per cent of the output comes from deposits in the Department of Ariège; other important deposits are at Montferrier, in the Pyrenees, about 12 miles from the Spanish line, and at Luzech. Another producing district is at Luzenac, near the port of Cette. French or tailors' chalk is produced mainly in the Department of Gard, near the port of Toulon.

102740°—23—2

on the Mediterreanean. Other districts in which talc and soapstone are mined are in the following Departments, named in order of importance: Pyrenees-Orientales, Isère, Aude, Savoie, Loire (Haute), and the island of Corsica. Immediately before the World War the production of talc was rapidly increasing, but during the war the production became almost negligible because of the shortage of labor. Mining will probably soon be resumed on its former scale.

#### ITALY.

The highest grade talcs in the world are mined in Italy. Their superior color, freedom from grit and impurities, and fineness of grain make them especially suited for toilet and medicinal uses and for lava blanks. The main producing district is in the Italian Alps in the neighborhood of Perosa, south of Turin, in the Valle di Chisone. Talc is mined also near Pinerolo and in the valleys of San Martino, Susa, and Lanzo.

#### CANADA.

Canadian talcs generally command a slightly higher price than those of eastern United States; some are suitable for certain grades of toilet powder, but most are used in the industries that demand a medium high-grade talc. The chief production comes from a group of mines near Madoc, Hastings County, Ontario. Several small mines have been operated in Brome, Megantic, Montmorency, and Wolfe Counties, Quebec, and in Cariboo County, and a few other localities in British Columbia. The production of the Madoc district has been rapidly growing and probably will be an increasingly important factor.

#### AUSTRIA-HUNGARY.

Before the World War Austria produced about 4.4 per cent of the present world production of talc and soapstone. The chief deposits of talc lie in the Province of Styria, about 100 miles southwest of Vienna, and in the communes of Mautern, Aflenz, Anger, Pollau, St. Kathrein, and Floing. Other producing districts are in Salzburg, Grusserhof, and Rohonecz, Hungary. The talc is high grade but not equal to that from Italy. Much Austrian talc was used in Germany for paper making. Austrian producers before the war formed an association which published results of research on talc and descriptions of many new uses.

#### SPAIN.

The talc production of Spain is small and comes mainly from the Province of Gerona on the southern slope of the Pyrenees, northwest of Barcelona; one mine is reported in the Province of Malaga.

**GERMANY.**

Important talc deposits are reported at Göpfersgrün near Wunsiedel, in the Fichtelgebirge, Bavaria, from which most of the German production came before the war.

**INDIA**

Massive talc of excellent quality has been mined in India for years, the natives using it for pots and kettles, but export trade has become important because of the suitability of Indian talc for lava manufacture. The largest production at present comes from the Jubbulpore district in the Central Provinces. Other producing districts are in the Provinces of Madras, Rajputna, Mysore, Bengal, Burma, Bombay, and Central India. Production in recent years has greatly increased, especially in Jubbulpore and at Miektila in Burma. The veins are usually thin but of high grade, and the resources are said to be large. Indian talc usually reaches the United States by way of England and thus separate import statistics are lacking.

**BRITISH SOUTH AFRICA.**

Talc is found in Natal and Rhodesia, but the most important production comes from the Barberton district in the Transvaal. There are large bodies of more or less pure talc in both Rhodesia and Transvaal. In the Barberton district pencils, tailors' chalk, billiard chalk, and ground talc are produced. An important industry sprang up during the war and supplied practically all local needs. Increased export trade is expected.

**BRAZIL.**

Though no exports of talc or soapstone are reported from Brazil, that country promises to be an important source. A pure white talc is reported at Rezende, State of Rio de Janeiro. Deposits at Lorena and Santo Amaro, both in the State of São Paulo, are also being mined. Good grades of massive talc, at present worked only by natives for local use, occur near Itaberaba, Bahia; Municipio de Ouro Preto; Varzea, near Dores da Bôa Esperança; near Jacuhy in western Minas Geraes; and in the States of Ceará and Goyaz.

**CHINA.**

Massive talc or high-grade soapstone has been mined for years in China, for the manufacture of carved utensils, images, and ornaments. Much of the material, though ideal for carving, is too highly colored for ground talc. The chief district has been the Tsintien, Chekiang Province, about 42 miles from Wenchow. Talc

is also found in the Provinces of Chihli and Fukien. Large deposits of high-grade talc have recently been reported near Tashih Chiao on the South Manchuria R. R., 148 miles from Dairen and 233 miles south of Mukden, South Manchuria; the talc is fine grained and translucent, pure white to flesh pink, some of the deposits being at least 20 feet thick. The best of them are owned by Japan, but some still belong to China. Shipments have been made to Japan, but none to the United States.

#### NORWAY.

Talc and soapstone both occur in Norway. Mills for the grinding of locally mined talc have been erected at the Songefjord, north of Bergen, and in Oistesto, Vikor, south of Bergen. In 1912-1914 the entire production came from Froastad i Oisteso and Hardanger in South Bergenhus Province, and in 1916 from North Bergenhus.

#### JAPAN.

Both talc and pyrophyllite occur in Japan in the Provinces of Hitachi, Kozuke, Musachi, Omi, Bizen, Suo, Hizen, Higo, Harima, Bingo, and Aki. Small imports of Japanese talc have been received in the United States, and it is probable that Japan may be a moderately important source.

#### BRITISH ISLES.

The mining of talc and soapstone is not important to-day in the British Isles, though several deposits are known and have been worked. Among these may be mentioned the Lizard district in Cornwall; Crohy Head and Gartan, near Letterkenny, in County Donegal, Ireland; the Shetland Isles; the Hebrides (Harris); and Shiness in Sutherland.

#### PHILIPPINES.

Several deposits of high-grade fibrous talc are known in Ilocos Norte. From tests and analyses this talc seems to be of excellent quality for paper filling and may become an important source in the future.

#### COLOMBIA.

The coast lands of the Goajira Peninsula, Colombia, near Castilletes, contain rich deposits of talc that are being worked for export to Venezuela, its value in 1918 being about \$4 a ton.

#### OTHER COUNTRIES.

Talc of a grade suitable for paper is reported as occurring near Heathcote, Australia. Deposits of talc of various grades occur in French South Africa, Jamaica, Sweden, the Netherlands, and Bel-

gium, from which countries small imports into the United States have been received. Talc of excellent quality, but in small quantities, comes from Syria, Mexico, and New Zealand; in fact, almost every country possesses some resources of talc or soapstone.

Accurate data on reserves are difficult to obtain, but the wide distribution of known though at present unworked deposits indicates that existing supplies are ample for years to come. Probably the United States will continue to lead in production, but the output of the Western States will doubtless become increasingly important. Deposits are now being worked in California and Washington, and many others have been noted in the Coast Range, the Sierra Nevadas, and in the Rockies.

#### EFFECT OF TRANSPORTATION ON GEOGRAPHICAL DISTRIBUTION.

As talc is a relatively low-priced commodity and its distribution throughout the world is general, transportation and distance from markets have influenced the location of new plants. The largest use of ground talc lies in the manufacture of paper, and its principal rival as a paper filler has been English clay. Most of the paper mills in the United States have been in New York and New England, and thus the talc deposits of New York and Vermont have been most fully developed because more easily able to compete with English clay brought into the ports of New York and Boston. In addition, the other industries that are large users of talc have been concentrated mostly in the northeastern States.

The most important deposits of talc of toilet grade in the United States are in California, Washington, and possibly in North Carolina and Georgia. The market for this grade is also mostly in the East, and before the World War the demand was mainly supplied by imports from Italy and France. During the war overseas imports were curtailed, prices rose rapidly, and Canadian imports increased, but California producers were able to compete in eastern markets despite the long railroad haul and the remoteness of the deposits from transportation. Thus California production increased rapidly. In 1920 the increased Canadian production, together with the resumption of imports from Italy and France, resulted in a record importation of high-grade talc. At the same time railroad freight rates increased greatly, and at the end of 1920 the California producers again found themselves unable to compete. The Canadian production is easily accessible to eastern markets, and both high and medium grade talcs can be provided by Canadian companies at a moderate price and with a comparatively small freight tariff. If the California producers could find a ready local market for large quantities of medium-grade talc, they might be able to lower their prices on the higher grades to meet competition.

In the South the remoteness of the deposits from railroads, the poor roads, the moderate size of the veins, and the lack of capital for improving transportation, for adequate prospecting and development, and for building efficient mills of large capacity, as well as the distance from the markets for medium-grade talcs, have prevented the growth of the industry. Thus the production has consisted mainly of talc pencils and metal-workers' crayons, which combine small bulk with relatively high value. Here again transportation, both to the railroad and by rail to the market, constitutes one of the most important controlling factors.

Deposits of talc of commercial grade are known in New Mexico, Nevada, Wyoming, Montana, and other Western States, but many of them are remote from transportation. In fact, one deposit of talc in New Mexico, 40 miles from a railroad, supposedly of lava grade, was opened and at least one car was shipped; but unless the material proves of exceptional grade the deposit probably can not be worked profitably. Talc deposits in the Western States may be classed with those of California, in that they will be of little commercial importance unless markets for large quantities of industrial-grade talc can be developed within a moderate freight haul, or until more accessible deposits are exhausted and the demand exceeds the supply so that prices rise. Lava-grade talc is so rare in the United States and its value is so high that a deposit of this material might be worked under unfavorable conditions.

#### FACTORS INFLUENCING NEW TALC-MINING VENTURES.

Before new talc mines are opened or new grinding mills are built a careful study of the demand and the costs should be made. In the history of the talc industry too many mines have been opened, too many mills built, and too many companies have been in the business at any given time, so that only a few companies have been very successful and then only during periods of prosperity. During 1921 there was enough talc-milling capacity in the United States ready for operation to supply at least twice the peak consumption of any preceding year. Some of these mills are so poorly situated or poorly designed that it is doubtful whether they can ever run at a profit.

Some of the factors that must be observed in order to conduct successfully a talc mining and grinding operation are as follows:

#### MARKETS AND PRICES.

Ground talcs of industrial grade come into direct competition with other mineral fillers such as clay, ground asbestos, mica, graphite, ochre, slate dust, whiting, ground silica, tripoli, and diatomaceous earth. For each use, therefore, talc must either have some superior quality or compete on a price basis or meet both conditions. Ground

tales, except toilet grade, normally range in price from \$8.50 to \$20 per ton, according to quality and fineness. With the present high freight rates, and the abundance of competitive materials, this low value greatly restricts the distance that talc can be shipped profitably. For example, it is impossible at present for California tales of industrial grade to compete with eastern tales and other competitive materials in the Eastern States. Most large consumers of industrial-grade talc are situated east of the Mississippi River and north of Virginia.

#### SIZE AND LOCATION OF DEPOSIT.

For economical operation a deposit of industrial-grade talc must maintain a daily production of at least 50 tons a day or 15,000 tons a year. In order that depreciation may not be too great, the life of a mine should not be much less than 15 years. Thus ore reserves of over 200,000 tons should be clearly blocked out before the opening of a mine or the building of a mill is considered. In addition, the vein should be thick enough and of such a character that mining operations would not be difficult or unduly expensive. If the deposit were much more than five miles from the nearest railroad siding, or if the roads were poor, or if there were heavy up-grades from the deposit to the railroad, haulage costs might be too high for economical operation.

#### PRESENT MILL CAPACITY.

At present the grinding-mill capacity of the United States is far in excess of the present apparent consuming capacity, consequently the construction of new mills is not justified unless the mine and the mill are near a large consuming center not now adequately served by existing mills, or unless new uses or markets have been developed that, as definitely known, will absorb the new production, or unless through improved methods of mining or milling a better product can be produced at a much lower cost than is common in present mills.

#### MINING AND MILLING METHODS.

Because of the present keen competition in the talc industry, haphazard methods of mining and milling can no longer be expected to be profitable. The best talc companies now employ skilled engineers and utilize every modern improvement in methods and machines. A new company entering the talc business should be in a position financially to obtain adequate technical advice and to buy the most modern and efficient equipment. Mining and milling methods should be under technical control so that standard grades of product of uniform quality can be guaranteed at all times.



### COST ACCOUNTING.

It is well established that comprehensive and accurate cost accounting is absolutely necessary to the successful operation of a talc company. Accounts should be so kept that it is possible at all times to know the cost of each stage of the process of mining and milling. Only in this way can inefficient operations be discovered and corrected. Adequate provision should be made not only for depreciation and obsolescence of the plant and equipment, but also for the depletion of the ore in the ground. Many apparently profitable mining operations have ultimately proved to be failures owing to the failure to recognize ore reserves as a wasting asset.

### ROYALTIES.

Talc mines may be opened on lands owned by the talc company or on leased lands. If on leased lands, a rental is paid, usually in the form of a fixed royalty per ton. If on owned lands, a charge is, or should be, placed on the books as a depletion charge to pay off a wasting asset, which practically amounts to a royalty. It is important, therefore, to establish a fair value per ton for talc in the ground. This value will depend on the grade of the talc; the distance of the deposit from the nearest railroad shipping point; the character of the roads; the size of the deposit and its accessibility for cheap mining; the quality, cost, and availability of labor; and the distance from the principal markets.

Royalties of \$0.50 to \$4 per ton have been noted, but these figures should not be taken as representing the range of royalties that are fair and profitable to either lessor or lessee. It would be a very unusual deposit, indeed, that would justify a royalty of \$4 per ton, unless the talc were of lava grade and then only if the deposit were small and other conditions were very favorable. So high a royalty could be paid in any event only on talc of toilet or lava grade for which there is a market for a comparatively small tonnage, although the price is fairly high.

If a royalty of \$4 per ton were paid, the production would be limited to a comparatively small quantity that would have to sell at a high price. No lower-priced talcs of industrial grade could be produced, because the high royalty would not permit a profit. But economical production can not be attained on a very small scale, therefore the operation would be conducted inefficiently, at a high cost, and with little profit. If 1,000 tons a year were mined at \$4 royalty per ton, the lessor would receive \$4,000 and the lessee might make even less and be forced to close down. But if 30,000 tons a year (100 tons a day) were mined at \$0.50 per ton royalty, the lessor would receive \$15,000 and the lessee could continue at a fair profit.

The extortion of a high royalty has often been disastrous both to lessor and lessee.

Probably for ordinary talc of industrial grade that sells, when ground, for \$8 to \$15 per ton a royalty range of \$0.25 to \$1 would be fair. For talc of toilet-powder grade the upper limit might be raised, under very favorable conditions, to \$1.50. Under ordinary circumstances royalties higher than this for deposits now known would not be justified. Under certain special conditions, where both toilet and industrial grades might be made, a sliding scale of royalties might be arranged whereby the smaller tonnage of high-grade talc produced would pay a higher royalty than the larger tonnage of medium grade.

### PROSPECTING AND DEVELOPMENT.

For the successful operation of a talc mine enough prospecting should be done before a mine is opened or a mill built to prove a large tonnage of talc of marketable grade. This point is discussed briefly elsewhere in this report (p. 15). Probably 200,000 tons is a minimum safe reserve on which to start operations; 500,000 tons would be much better. Unfortunately, few companies in the past have done adequate prospecting; after some mills were built not enough talc was available to keep them running. When a definite tonnage has been blocked out and a mine opened, it is equally important that prospecting and development be continued so that a large supply of ore may always be blocked out in advance of actual mining.

Prospecting may be done by surface trenching, by drilling—either with a diamond drill or a churn drill—or by the underground methods of shaft sinking, tunneling, drifting, crosscutting, or raising. The one talc company that has used diamond drilling extensively has blocked out definitely millions of tons of ore by this method. A few other companies have used the diamond drill merely to locate veins of talc but not to block out definite tonnages. Thorough diamond drilling is probably the best and, in the end, the cheapest method of prospecting and developing talc deposits. The use of underground methods if properly carried out is very efficient, but they are slow and expensive unless the openings made can later be utilized in mining the deposit. Prospecting by surface trenches is useful only in finding deposits and in determining their approximate surface extent; it never can be used for actual development or for blocking out ore reserves.

In order to permit the making of reasonably safe estimates of ore reserves a deposit must be blocked out clearly in three dimensions by drill holes or openings close enough together to warrant the safe assumption of continuity of deposit. One or two openings that

merely touch the vein but do not cut through it give little or no indication of the size of a deposit. Moreover, float ore scattered about the surface is no indication of the presence of a workable deposit. Prospect openings should cut entirely through ore in place at numerous points, so that the length, depth, and thickness of the deposit may be determined definitely. It is much more important to locate development openings for an accurate estimate of tonnage than merely to prove the presence of ore over a large area by means of scattered openings improperly made. Of the many deposits visited by the author, very few had been adequately prospected or developed.

A characteristic common to many talc producers is unwillingness to drive prospecting or developing openings through waste rock. Yet in many instances such work would probably yield valuable information. Many talc deposits are lenses in schistose rocks and do not constitute a definite vein; several lenses may lie more or less parallel to each other and be separated by varying thicknesses of barren rock. In mining deposits of this nature it is always desirable to drive small crosscuts into the hanging and foot walls at frequent intervals to search for parallel lenses. In a Vermont mine (for example) a large lens was worked out without any exploratory crosscuts being driven; subsequently a diamond drill hole from the surface proved the existence of a parallel ore body larger than the one previously worked. When this second ore body was opened up, it was discovered that the deposit could have been developed by a short crosscut from the old mine. Sometimes small exploratory drifts and crosscuts 50 or even 100 feet long through waste rock would be justified.

#### QUARRYING AND MILLING OF SLAB SOAPSTONE.

All of the talc produced for grinding purposes with a few minor exceptions is mined underground. At the exceptional deposits, the operations are so small and relatively unimportant that descriptions here are not warranted. Massive soapstone produced for the manufacture of soapstone sinks, tubs, tanks, laboratory hoods, and table tops is all obtained from open quarries. As this phase of the talc and soapstone industry differs so entirely from the other phases under consideration, and as the quarrying and milling operations resemble so closely those used in the marble industry, they will not be discussed in this report. Marble quarrying and milling has been well described in a bulletin of the Bureau of Mines by Oliver Bowles.<sup>8</sup>

<sup>8</sup> Bowles, Oliver, Technology of marble quarrying: Bull. 106, Bureau of Mines, 1916, 174 pp.

### MINING METHODS.

The mining of talc in most districts is characterized by the absence of definite methods, because of the comparative youth of the industry, the early development of deposits by men unfamiliar with mining, the lack of proper prospecting and development, and sometimes to the irregularity of deposits. Fortunately, the more progressive companies now maintain adequate engineering departments and give more attention to efficiency and economy in mining. Probably the most common practice in talc mining to-day utilizes the following principles.

#### OPENINGS TO SURFACE.

Shafts are usually sunk in the ore body or on the footwall at an inclination corresponding to the dip of the vein and changing with the dip. Inclined shafts of uniform dip are to be preferred to those of changing dip. Vertical curves or bends in the skip track often cause derailments and necessitate a low hoisting speed. Shafts are usually small and have beside the skip track a stairway or ladderway which should have landings about every 20 feet vertically, and should be separated from the skipway by a strong partition or by lagging. These safety precautions are sometimes omitted, but their omission has led to many serious accidents. Recently the advantages of vertical over inclined shafts have been recognized, and at one deposit, at least, a modern concrete-lined vertical shaft has been sunk. If vertical shafts are used, they should be in the footwall in order to prevent dislocation from the movement caused by surface subsidence. The laws of some States now require that at least two openings to the surface shall be maintained. The following of this practice is strongly urged in all States, for a second opening is not only advisable because of safety, but aids ventilation and thus increases efficiency.

Adits or tunnels are used in place of shafts where surface conditions permit. Such adits should be at least 6 by 6 feet in the clear, should be straight, well timbered, and on a grade that suffices to balance the pull on the outgoing loaded cars and the incoming empties. At many of the mines visited the adits have been too small, crooked, and not on a uniform grade. The first cost of driving an adequate working tunnel is not much greater than that for a poor one, and the increased efficiency more than compensates for the additional cost.

#### DRIFTING, CROSSCUTTING AND RAISING.

In many talc mines the walls of the deposits are so irregular that the boundaries have to be determined by development drifts. These drifts, of course, can not be straight and may well be narrow. After

the deposit is outlined, however, these crooked narrow drifts are often used for working drifts. In such event, it would often pay, especially in wide veins, either to open new, straight drifts of proper size, or to widen the development drifts and straighten out the sharper curves. The importance of maintaining proper, well-timbered working places and haulage ways is often overlooked. In some mines efficiency could be so increased in this way that lowered costs and increased production would result. Crosscuts for development may be small, but working crosscuts should be at least 6 by 6 feet in the clear. Raises when used as development openings must follow the dip of the ore body, but when used for ore chutes they should be driven, if possible, at an angle that will allow the ore to run freely, and should be of uniform slope. If the raise is needed on the footwall and the dip of the vein is less than the required angle, some ore has to be left on the footwall; but this ore may be recovered eventually and the practice is justified amply by the increased facility in handling the ore. In most talc mines raises are driven from the floor of drifts, and ore that comes from the raises must be shoveled by hand into cars, involving unnecessary labor which could be obviated by the use of chutes and gates.

#### STOPING.

The chief factors governing stoping methods are width of ore body; strength, hardness, and uniformity of walls and ore; and size of output desired. In many talc mines these factors have not been studied enough, and the methods of mining used are not the most economical or the most efficient. Not only do inefficient mining methods increase waste and lower efficiency, but they may also have an important effect on milling practice and on the grade of the finished product. Admixture of waste with ore in mining may increase haulage costs, make sorting by hand necessary, increase the load on milling machinery, and lower the grade of the finished product. The presence of excessive moisture increases the possibility of iron staining, raises drying costs, or, if no driers are used, decreases grinding capacity and clogs the machinery and bins. Thus the mining problem involves more than the mere removal of the talc from the ground.

The following general method of mining is used in a number of the larger mines, regardless of the size, shape, or attitude of the ore deposits: Drifts outlining the body are driven 15 to 20 feet wide—or the width of the vein, if less than 20 feet—and 7 to 20 feet high. If the ore body is wide enough, crosscuts are driven from wall to wall and two or more such drifts are cut, with ample pillars between them. At frequent but irregular intervals raises varying in size from 8

to 25 feet square are put up on the footwall or in the ore on an inclination of about  $45^{\circ}$ . Sometimes these raises are perpendicular to the drifts and sometimes they branch at angles of about  $45^{\circ}$  with the drift. Horses of waste are left standing as pillars wherever possible. Ore from the raises is usually allowed to roll to the drifts and is shoveled into cars. In one or two mines raises are started narrow, are widened out above the drift, and chutes and loading gates installed. This modification is advisable where possible.

After the limits of the ore body have been reached, both laterally and in depth, pillars farthest from the shaft are pulled. Then, in retreating toward the shaft from both directions, all ore possible is recovered and the workings are allowed to cave. The disadvantages of this method are that usually not more than 40 to 50 per cent of the ore may be removed on first mining; large unproductive openings must be maintained over long periods of time; backs of raises and drifts are inaccessible for inspection and scaling; and falls of rock and cave-ins often make impossible the final recovery of pillars.

The most efficient system observed is worthy of careful consideration. For a detailed description of this mine see page 122. The ore body varies in width from 15 to 70 feet, with an average of about 35 feet. It dips at a steep angle, has firm, well-defined walls, and contains little or no waste. The ore stands well, but requires drift timbers in places. The deposit is opened by a vertical shaft in the footwall with crosscuts to the vein. Drifts are run along the footwall outlining the body, and small raises are put up at frequent and uniform intervals. Fifteen or twenty feet above the drifts the raises are gradually widened out to the full width of the vein, the sides being maintained at an angle that permits the broken ore to run readily. Several raises may be joined to make one stope, but ample pillars are left between stopes. Thus heavy horizontal pillars are left to protect the drifts, and vertical ribs to hold the walls. Enough broken ore is left in the stopes to permit the back to be reached readily, the surplus being drawn off through chutes and gates at the foot of the raises. Stopes are continued up to the surface or to the level above, and then are left full of ore. When ore is needed it is drawn off, allowing the material above to cave and fall in. Drawing of ore is stopped when waste appears at the gates. Recovery of the pillars has not yet been attempted at this mine, but it might be accomplished after a level was worked out and all subsidence has ceased. By putting up small raises in the pillars to the top and stoping the ore underhand into the raise most of the ore could be recovered. If the pillars were not strong enough raises could be put in one of the walls and connections made into the pillars.

This method of mining, known to metal miners as shrinkage stoping, is excellent for veins of moderate width that have strong, well-defined walls. Some of its advantages are as follows: All ore is broken by overhand stoping; many working places are available; few men are needed underground as no shoveling is necessary; no timber is required in stopes; there are no high, open stopes, with danger from falling roof; large storage for broken ore is available at no cost; ore is not as liable to be water-soaked, the stopes being self-draining. The chief disadvantage is that ore may arch or hang up in the chutes, but usually such a jam may be broken by shooting with dynamite.

Any ideal mining method must be adapted to the conditions at each mine, and the successful use of this method at one talc mine suggests the possibility of its adaptation to other mines.

#### TIMBERING.

In most talc mines, the item of timbering is not of major importance. In some mines no timber at all is used to support the ground. In one mine, however, the ore and walls are badly crushed in places, necessitating the use of heavy timbers and close lagging. When ground of this nature is encountered in drifting, attempts are made to drift around the loose ground in solid ore. Excessive timbering is thus obviated, with the sacrifice of some ore and of some efficiency in haulage.

#### DRILLING AND SHOOTING.

Talc usually is drilled easily and is broken with a small amount of dynamite. Consequently, little attention is sometimes paid to drilling and shooting, and the best methods are not always used. The use of a center wedge or a V-cut, as it is variously known, in drifting—that is, the drilling and shooting out of a set of converging holes in the center of the drift—is not common. The side cut is used to some extent and one or two other methods were noted, but in many mines drilling and shooting have not been systematized.

Experience over a long period of years has shown, both in this country and abroad, that the use of a wedge cut or its modifications, the pyramid cut, or bottom cut, in all tunneling operations is the cheapest, quickest, and most efficient method. Most talc mines would be benefited by a study of drifting and raising methods and the application of the wedge-cut principle.<sup>9</sup>

<sup>9</sup> Brunton, D. W., and Davis, J. A., Safety and efficiency in mine tunneling: Bull. 57, Bureau of Mines, 1914, 271 pp.; Munroe, C. C., and Hall, Clarence, A primer on explosives for metal miners and quarrymen: Bull. 80, Bureau of Mines, 1915, 125 pp.; Peele, Robert, Mining engineers' handbook, 1918, pp. 459-480.

In drilling, compressed-air drills of the "Jackhammer" or "Rotator" type are almost universally used. Sometimes they are mounted on a light column or even a tripod, but usually they are held to the face by hand. In raising and in overhand stoping several types of stoper drills are used, but the larger types of piston drills and mounted hammer drills are seldom seen. The ore and walls in practically all the talc mines examined are so moist that the dust problem in drilling is not serious, and no water sprays or similar devices are used. At one mine electric drills were tried out, but they proved unsuccessful and were replaced by air drills. There is no uniformity in the grade and type of explosives used in talc mines. On account of the absence of inflammable gases or explosive dusts, and as ventilation is usually good, economy and efficiency are the principal factors in the selection of explosives. Black powder is not used, owing to the danger of discoloring the talc by smoke. The Bureau of Mines publications on the selection and use of explosives present a complete discussion of blasting in mines and quarries.

In stoping, the placing and loading of holes has an important bearing, not only on cost and efficiency but on the subsequent operations of sorting, drying, and milling. Ore broken smaller than 2 inches absorbs more moisture than larger pieces; it tends to pack down, clog, and stick in chutes, cars, skips, and crushers; it can not be sorted by hand, and it usually must be dried either in the air or mechanically. On the other hand, ore not properly broken in primary blasting must be either sledged by hand or blasted again; if ore chutes and gates are used, large pieces of ore often clog the chute and are difficult to remove or break. Both extremes in practice have been noted. At one mine it is the custom to shoot down very large pieces of ore and break them by secondary blasting—either mud-capping (bulldozing) or block-holing—an inefficient operation because of the rehandling necessary, and probably as many fines are made as if heavier primary blasts were used. At another mine, where the ore is somewhat fractured, probably too heavy shots were used, and the proportion of fines might be lessened by lighter shooting, even if some secondary blasting were necessary. The most economical ratio between primary and secondary blasting can be determined only by successive trials in each individual case, keeping in mind the relative costs of drilling, explosives, and drying, and the need for sorting out waste. Secondary blasting can also be lessened by the use of larger preliminary crushers in mills.

#### LOADING.

The loading of crude ore underground is done entirely by hand shoveling except in the few mines where chutes and gates are used.



In one mine planks are always laid down close to the face of a drift or at the foot of a raise before shooting. This practice has several advantages; it keeps the broken ore from absorbing water from the floor; it lessens the danger of iron-staining from rails, pipes, and mine water; and it makes shoveling easier. Wider use of this practice is urged. Automatic shoveling machines have not yet been introduced in talc mines, but mines having a large output and using large, open stopes could probably use them to advantage.

#### HAULAGE, HOISTING, AND SIGNALING.

At all of the talc mines visited tramping of ore underground is done entirely by hand or animal. One mine, opened by an adit, had grade enough to allow the loaded cars to roll out by gravity. Here 1-ton, wooden, end-dump cars are used and the empties are hauled back to the face, in trips of five cars each, by a horse. In most mines steel cars are used, of one-half to 1 ton capacity, either end-dump or revolving dump, of gages ranging from 18 to 30 inches. Not enough attention is given at many mines to the proper construction and maintenance of haulage ways. Tracks should be straight, of uniform gage and grade, and properly drained and ballasted. Derailed cars, particularly if loaded, cause expensive delays. Money spent in the proper maintenance of rolling stock and haulage ways is well invested. The mining of talc is not usually done on a scale large enough to warrant the use of mechanical haulage, but in a few of the larger mines, which use electric power underground, the use of storage-battery locomotives might be advisable.

The use of a single hoisting skip in talc mines is almost universal and in most mines the loaded cars are dumped directly into the skip. This arrangement is satisfactory for a small production, but is inefficient for medium or large output. Loading pockets at the shaft are used at some of the larger mines. The pocket should be large enough to hold several skip loads of ore and should be provided with a measuring chute, so that the skip may be loaded full but not overflow. By the use of the shaftpocket the hoisting and haulage systems are made independent; in case of accident to either system, the operation of the other will not be hindered. Furthermore, where the skip and the mine cars are not of the same capacity both may be loaded full on every trip. Self-dumping steel skips carrying 1 to 1½ tons are in general use. It is important that the skip track be straight, of uniform grade and gage, well aligned, and with heavy enough rail that it will not bend. In several mines skip ways are in very bad condition. They are cut too small, are crooked, of uneven grade, laid with very light rail, and not properly supported. Derailments, which are frequent under such conditions, are not only

expensive but are dangerous, particularly when the ladderway is not lagged off from the skipway.

Serious accidents have occurred in talc-mine shafts from derailments, breaking of hoisting cables, and poor signal systems. Proper care of skipways, protection of ladderways, and frequent inspection of ropes should obviate accidents from derailments, and lessen the danger from broken ropes. Men should not be allowed to work at the bottom of skipways during hoisting or while the skip is off the bottom. If such work is necessary, the skip should be securely blocked in position or a steel-bar drag should be attached to the rear of the skip, so that if the rope breaks the skip will be derailed or automatically blocked in place. Improper signal systems have been responsible for many fatal accidents. Electric signals should be used which provide for the return of signals by the hoisting engineer to the level below before hoisting. When the repeated signal is received underground, proving that the original signal was received, the starting signal should be given. The signal code used should be posted prominently at each level.

The mining laws of some States require that mine telephones be installed underground, connecting the working faces, shaft stations, and engine room. Whether required or not the installation of a system of mine telephones is a desirable aid to efficiency and safety.

#### DRAINAGE.

In some talc mines the problem of drainage is important. Heavy flows of water have caused complete abandonment of several profitable mines. Other mines have been flooded repeatedly and for long periods, though finally the water has been controlled. The design of mine pumps has been improved greatly in the last decade so that water problems formerly deemed too costly to handle can now be treated successfully. It is possible or even probable that some talc mines now flooded will eventually be pumped out and reopened. At mines now operated the flow of water varies from a few gallons an hour in some mines in dry weather to a maximum of 850 gallons per minute at one mine in wet seasons. Drainage is a vital problem. In talc mines the staining of the ore by iron-bearing water, and the absorption of moisture by the ore which necessitates drying before grinding, are factors not of importance in metal mines. The quantity of water to be pumped can often be reduced by careful ditching around shafts and around caved ground and by the construction of concrete or tile drains over surface cracks and permeable strata. In shafts streams of water can often be cut off by grouting with cement under pressure and by the use of concrete linings.

A noticeable feature at some mines is the inadequate pump capacity. Enough underground storage should be provided for water so

102740°—23—3

that under adverse conditions pumps may be stopped for several hours at least, without flooding the mine. Some pumps are so situated that they would be completely flooded in a few hours if they stopped, and the water could then be removed only by bringing in other pumps from the surface.

As a motive power for pumps, steam, compressed air, and electricity are all in use, but electrically driven pumps are probably the most common. Steam pumps are objectionable underground, on account of the difficulty of disposing of the exhaust steam. Compressed-air pumps are inefficient in their use of power, but are convenient for temporary use. Electric pumps may be of the geared or of the centrifugal type, each having its advantages under certain conditions. The selection of proper pumping equipment for heavy duty may usually be left to the engineering department maintained by the large companies that manufacture all types of pumps. Adequate pumping capacity should be provided to take care of a surplus over the possible peak load. An example of the successful solution of a difficult pumping problem is given on page 103.

#### VENTILATION.

No explosive or inflammable dusts or gases are ordinarily found in talc mines; drilling and shooting of talc rock produce little objectionable dust; little timber is used, and in many mines large open stopes are maintained. Thus the problem of ventilation is not often acute. In practically all mines examined the air was cool and seemingly pure, although no artificial ventilation is used. In some of the larger mines artificial ventilation may be necessary in the future as deeper levels are opened, but many deposits are not of large enough lateral extent or deep enough to suggest the probability of such need.

#### LIGHTING.

Good lighting as an aid to efficiency and safety is becoming more generally recognized, and in some mines electric lighting is used in part. It is advisable to place lights at shaft stations, pumping stations, loading bins, and at frequent intervals along main drifts and crosscuts. Good lighting pays in increased efficiency and safety. The use of carbide miners' lamps is now almost universal, though in a few mines candles, oil lamps, and "sunshine" lamps were noted. The efficiency of carbide lamps recommends their universal use where open-flame lights are permissible.

#### SURFACE ARRANGEMENTS.

At many talc mines little attention has been given to the proper location of surface structures, pump discharges, tracks, and so on.

At one mine, until recently, the pump discharge was so situated that a large part of the water found its way back into the mine through surface cracks, permeable strata, and even down the shaft. At another mine the ore is rehandled twice before it reaches the crude-ore bins or stock piles; in still another, ore and waste mixed together are hauled out of a tunnel and unloaded by hand beside the track, where the waste is sorted out, reloaded into a car, and trammed out on the waste dump. The good talc, which in this case is pencil stock, is picked up and carried by hand into the mill. These examples and many others are evidences of lack of planning for the future and are the result of thoughtless, haphazard growth. Such inefficiency cuts down production and increases cost.

In opening a new mine it is desirable first to establish the dip, strike, size, and general outline of the ore body. Then a surface map should be prepared indicating the underground data, and showing such surface features as the contour of the ground, the location of streams, swamps, rock ledges, roads, railroad, and power lines. Surface structures may be laid out on this map, determining the most efficient and economical arrangement and allowing for future expansion.

If the vein has a decided dip, surface structures, including the headframe, should be placed, if possible, on the footwall side, so that they will not be disturbed by any future subsidence or caving. Instances have been noted of surface subsidence necessitating the sinking of a new shaft and the relocation of all surface structures. As the underground workings progress, they should be mapped accurately and the outlines placed on the surface map, to obviate the undermining of buildings, the breaking through of rivers or other bodies of water, or the mining beyond property lines. Many mines have been flooded and miners drowned because no maps were kept for correlating underground workings with surface features. Mine maps have been considered by some talc companies as a useless extravagance, but their importance can not be overstated. Only by the use of accurate, up-to-date maps can pillars, stopes, sumps, raises, and drifts be located properly with regard to safety, efficiency, proper ventilation, and drainage, and the highest possible extraction of talc. Recent accidents from cave-ins in talc mines in New York were the result of undermining of pillars because of a lack of mine maps. Fortunately the mining laws of most States now require that accurate mine maps be kept.

If the mine and mill are close together, it may be possible to dump the mine cars directly into the mill bins, as pictured in Plate I, *B* (p. 30), or to hoist the mine skip so that it dumps into the mill bins as shown in Plate I, *A* (p. 30). Such an arrangement is very efficient and should be followed where conditions permit. If waste is handled

out of the same mine, however, provision for openings above the mill bin must be made for sorting the ore and for the disposal of waste. If the mill is at a distance from the mine, crude-ore storage bins should be provided, into which the mine skip or cars dump directly. These bins should hold at least a day's run of ore and as much more as space will permit. Usually such bins should be divided into several compartments, so that different grades of ore can be kept separately. (See p. 94.) Provision should be made for sorting ore and for disposing of waste at the top of the bins, and chutes and gates should be located at the bottom, at the proper height above the ground, so that loading from several gates may proceed at the same time. In order that ore may be distributed evenly over the bin or bins, one company has installed a long inclined chute leading from the skip dumping point to the farthest end of a row of bins. At intervals along the bottom of the chute are openings with trap doors; by the opening or closing of these doors ore can be run into any section of the system of bins. The use of stock piles for crude talc is not efficient or economical, for the material must be rehandled by hand, and the ore accumulates moisture, which must be removed later by drying if efficient dry grinding is to be done. While the surface of an uncovered stock pile may dry out a little, the material underneath absorbs and holds rain water, which more than offsets the drying of the surface.

#### MINING PLANT.

Hoisting machinery now in use has become so standardized that it requires little mention here. Most of the hoisting engines seen have been efficient, but there is a tendency to underestimate the size of hoist necessary. At one mine two changes increasing the size of the hoist were made in rapid succession, on account of poor judgment and lack of foresight in the selection of the first and second hoists. At some other mines the hoists were barely able to raise a medium-size skip load from a moderate depth. Selection of a hoist with a fair overload capacity is desirable.

Hoists, air compressors, pumps, boilers, and engines of efficient types were noted; but here, too, appeared a tendency to underestimate the size and capacity needed. One talc mine was drowned out and its recovery required several months because the necessary pumping capacity had been underestimated. An adequate initial investment will often save much time and money later.

Every mine and mill should be provided with well-equipped carpenter and machine shops unless they are near a city where such shops are available. If the mine and mill are close together, one shop may be enough, but if far apart, the mine should have at least a good blacksmith shop for sharpening drill steel and picks and for

making minor repairs. At almost every mine, even of moderate size, where much drilling is done, the installation of an automatic compressed-air drill sharpener is a good investment. Good drill bits are essential for cheap drilling, and no blacksmith can make as good bits by hand as can be made by machine. Mill shops are almost a necessity, as shutdowns for repairs may be very expensive.

Steam power at mines and mills is being rapidly displaced by electricity, most of the large companies and many of the smaller ones now using electrically driven air compressors, hoists, and pumps. Where a dependable source of cheap electric power is available, the advantages of electricity over steam are unquestionable.

### TRANSPORTATION TO MILL.

If the mill is far from the mine, the item of transportation between mine and mill may be highly important. It is generally preferable to build the mill at a railroad siding and haul the crude ore to it rather than to build the mill at the mine and haul finished talc to the railroad. Talc packed in paper sacks will not stand much rehandling, so the hauling of finished talc packed in this way may result in excessive losses. If the mill is at the railroad, cars may be loaded more rapidly from stock stored in the warehouse. Crude talc may be handled mechanically, but finished stock usually must be loaded and unloaded by hand. Crude talc is sometimes hauled to the railroad, loaded into cars, and shipped some distance to a mill in or near a large city. If the mine is in a remote district where labor is not plentiful and fuel or power is not available, this arrangement is desirable, but it involves some rehandling and additional freight charges.

At a few mines where the mill is not far distant, but is so situated that mine cars or skips can not dump directly into mill bins, an aerial tramway is used. At East Granville, N. Y., mine cars of  $\frac{3}{4}$ -ton capacity are dumped into a bin of 7 to 8 tons capacity. From the bottom of the bin ore is drawn into buckets holding 500 to 600 pounds, running on an inclined cableway, 1,400 feet long, down to the mill, where they dump into a chute leading to the mill floor. Two buckets are used, the load pulling the empty bucket back and the speed being controlled by friction drums at the top. This cableway was the longest noted at any talc mine, nevertheless the use of such a cableway or aerial tramway would be much more economical than the methods of transportation now in use at many mines. In a rugged country with poor roads and steep grades the erection of an aerial tramway should be carefully considered. At several talc mills visited operations are seriously hampered, particularly in winter, by poor facilities for transportation from the mine. For most of these mills a

narrow-gage railway is not feasible, but an aerial tramway would be suitable. For more detailed information on this subject see Peele's Mining engineers' handbook.<sup>10</sup>

The most common form of transportation is by wagon or, in the North in winter, by sled. It is customary to let out such hauling on contract to farmers at a fixed price per ton or load, or at some mines by the day. Wagon hauls up to 18 miles have been noted, the load varying from 1 ton to a maximum of about 3 tons. At one talc mine in Vermont in 1919, where the haul was about 11 miles downhill over a fair country road, wagons on contract carried an average of 3 tons per load at \$2 a ton. This company also owned two 2-ton motor trucks, which hauled an average of 2½ tons per load, at a cost of a little over a dollar per ton. The heaviest hauling here is done in winter by sled, and the surplus talc is stocked at the mill, as hauling by sled is cheaper than hauling by wagon. At a talc mine in New York in 1920 talc was hauled by wagon on contract for a distance of 2 miles over a nearly level road of fair quality at \$1 per ton. Wagons usually made three round trips a day and averaged 3 tons per load. Haulage by wagon on contract is sometimes unsatisfactory when farmers do the hauling, as their teams are unavailable at some seasons of the year.

Motor trucks, either owned by the company or on contract, are used at some mines, but their use has not been entirely successful. In the North trucks can be used only part of the year, on account of heavy snows; in the South the roads are often too poor for trucks. Moreover, many roads are so rough that the repairs and upkeep of trucks are excessive. In some places where truck haulage has been tried it has been unsuccessful, and wagon haulage has been revived.

For operations on a large scale, narrow-gage railways have proved very successful. At Rochester, Vt., the mines and the mill are connected by a system of 36-inch-gage industrial track. The two most widely separated mine openings are about 1,500 feet apart and the other two about 600 feet. The distance from the nearest opening to the top of the incline at the mill is about 4½ miles by rail, the total haul being less than 5 miles. The mines are at elevations higher than the top of the mill incline, so that several switchbacks are required to avoid an excessive grade. The cars used are V-shaped, rocker-dump steel cars with a capacity of 6 tons, provided with heavy brakes and regular railroad couplings. These cars are loaded from tip-up spouts at the mine bins, and are hauled in a trip of six to eight cars to the mill incline by a saddle-tank steam locomotive. In wet weather the loaded cars are covered with oilskins to keep out the water. Enough cars are provided so that the locomotive

<sup>10</sup> Peele, Robert, Mining engineers' handbook, New York, 1918, pp. 1555-1598.

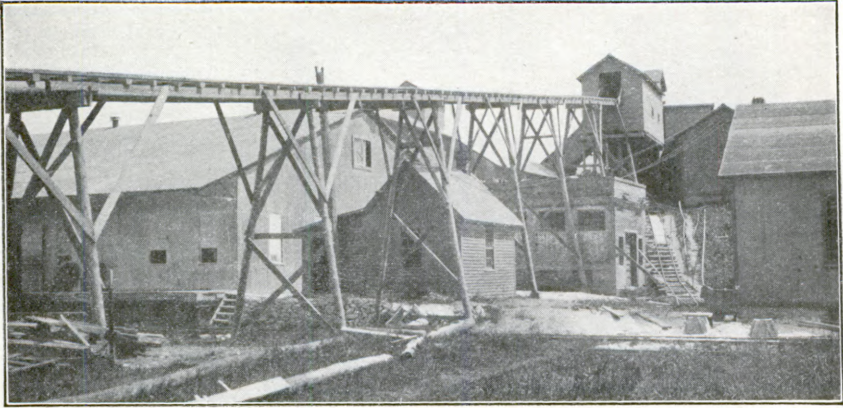

A. MILL AND INCLINE FROM MINE. UNIFORM FIBROUS TALC CO., TALCVILLE, N. Y.

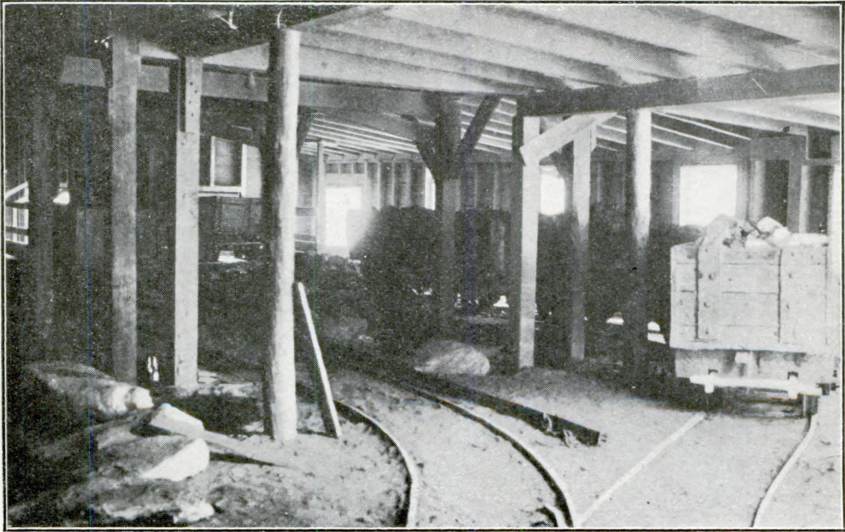

B. TOP OF MILL BINS SHOWING MINE CARS READY TO BE DUMPED. MAGNESIA TALC CO., WATERBURY, VT.

Generated at University of Michigan on 2023-02-13 11:27 GMT / https://hdl.handle.net/2027/uidg.30112104112039  
Public Domain, Google-digitized / http://www.hathitrust.org/access\_use#pd-google



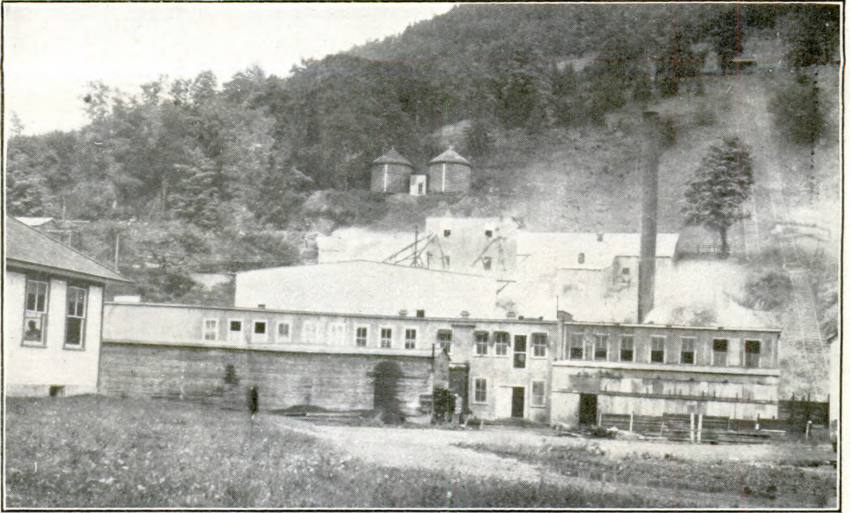

A. TALC MILL AND INCLINE FROM MINE TRACK. EASTERN TALC CO., NEAR ROCHESTER, VT.

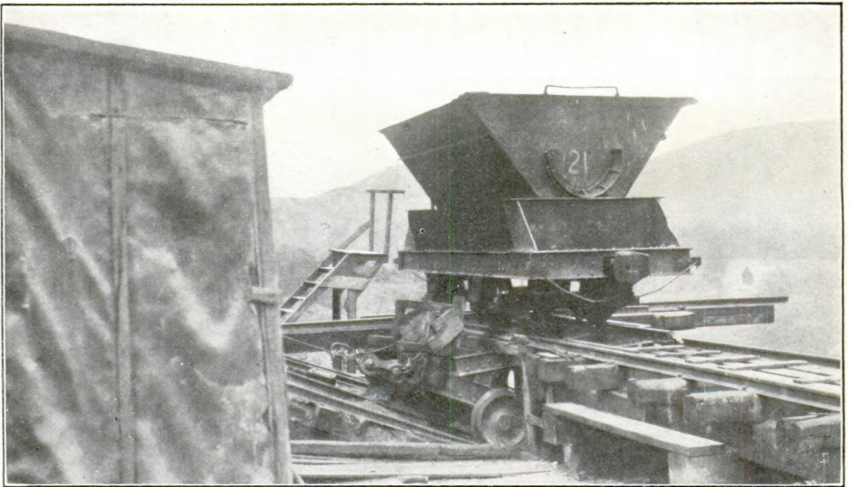

B. TRUCK AND CAR FOR INCLINE CABLEWAY SHOWN ABOVE.

Generated at University of Michigan on 2023-02-13 11:27 GMT / https://hdl.handle.net/2027/uig.30112104112039  
Public Domain, Google-digitized / http://www.hathitrust.org/access\_use#pd-google



A. FEED SPOUT FOR BELT CONVEYOR. MAGNESIA TALC CO., WATERBURY, VT.

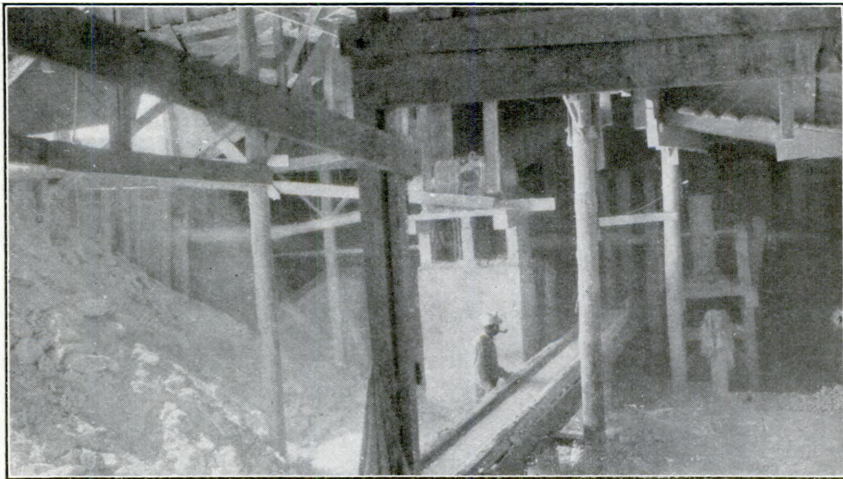

B. BELT CONVEYOR RECLAIMING CRUDE TALC. OLD MILL OF THE AMERICAN MINERAL CO., JOHNSON, VT.

Generated at University of Michigan on 2023-02-13 11:27 GMT / <https://hdl.handle.net/2027/uiug-30112104112039>  
Public Domain, Google-digitized / [http://www.hathitrust.org/access\\_use#pd-goo](http://www.hathitrust.org/access_use#pd-goo)

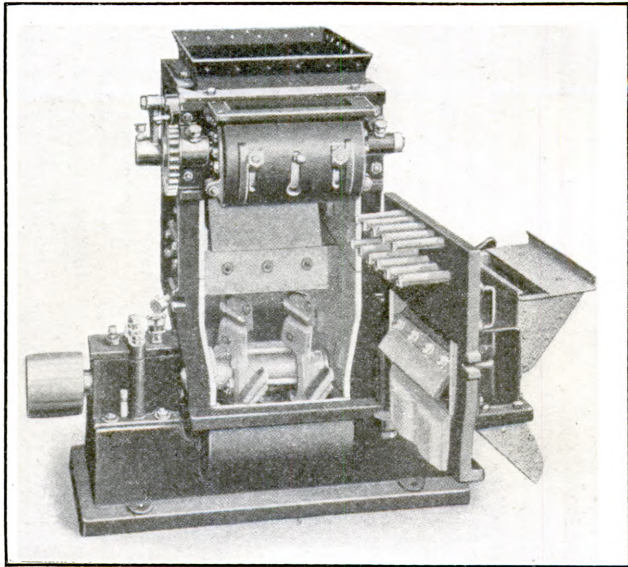

4. RAYMOND PULVERIZER EQUIPPED WITH AUTOMATIC THROWOUT ATTACHMENT.

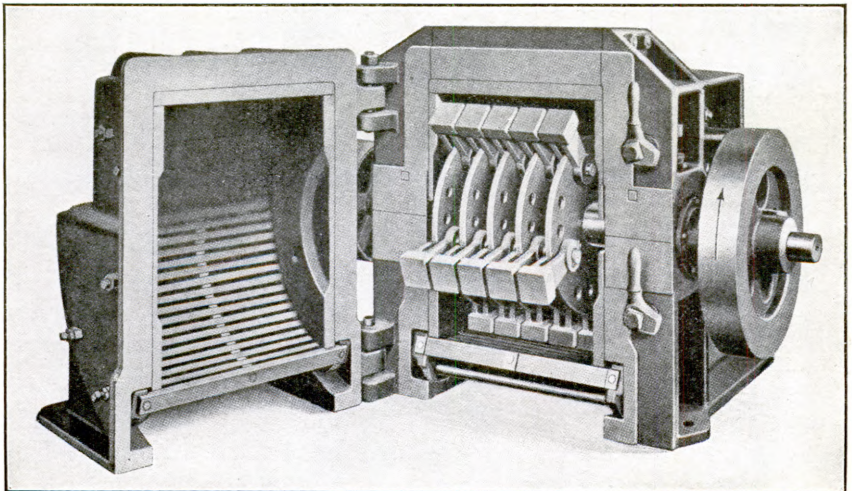

B. HAMMER MILL.

need not have to wait for loads. At the mill is a standard-gage double-track incline (see Pl. II, *A*), about 300 feet long, from the railroad terminus to the top of the mill. One track is extended to the bottom level of the mill so that coal and supplies for the mines may be transferred to the upper track. On each of the incline tracks runs a truck, so built that its upper deck is level. On the deck is a short section of 36-inch gage track that holds one car. A loaded car is pushed on the truck, locked in place, and lowered by gravity to the mill-bin tracks, where the truck is blocked in place, the car unlocked, and pushed out on the mill-bin tracks. The descending truck, whose speed is controlled by a friction drum at the top, hauls an empty car on its truck to the top ready for loading. Between the two incline tracks, at the bottom, the mill track is pivoted in sections so that it may be swung out of the way when the load descends on the near track. The incline truck and car are shown in position at the lower terminus in Plate II, *B*. By this system a rather difficult hauling problem was satisfactorily solved, but, in June, 1919, plans were under way to change the grade of the mine tracks, so that cars could be brought directly to the mill and the use of the incline eliminated.

#### MILLING.

#### HISTORY.

Methods of milling talc have not been standardized, and no data have been published showing the relative efficiencies of the different types of grinding and separating machinery. The talc and soap-stone first used in this country were of the massive varieties which were cut into griddles, foot warmers, and such articles. Several of the Vermont talc deposits were opened to obtain such material. When a demand for ground talc arose, flour-grinding mills were utilized; and for some time flour-milling machinery, with its buhr mills and its silk-bolting reels, was used. Gradually this kind of machinery was proved unsatisfactory and uneconomical; the grinding capacity was small, and the silk-bolting cloth soon wore out, on account of the talc being heavier than flour and containing abrasive grit and other impurities. To-day few of such mills exist, although in one Canadian mill the silk-bolting reels are still retained, in conjunction with tube mills, with seeming success. In the United States only one mill was noted that still uses the old type of flour-mill machinery and still grinds both grain and talc.

Gradually two general systems of milling developed. In New York—where the talc is of unusual hardness and is usually mixed with tremolite—tube mills, first of the intermittent-dump cylin-

der type and later of the continuous type, were adopted, with no screening or separation of the finished product. In Vermont, development was in the direction of vertical emery mills, disintegrators, pulverizers, and roller mills, equipped with vibrating screens for the coarser sizes and with air separation for the finer sizes. In the South development has not been as rapid, and no distinctive methods are used. In California the talc industry first attained importance during the World War. In the construction of new plants producers were able to take advantage of the experience gained in New York and Vermont, adapting their methods from those used in Vermont.

#### NEED FOR PROPER METHODS.

The value of using the most efficient methods of grinding has not always been understood. In the early days of the industry any method that would reduce talc to a fine powder was considered satisfactory, an idea that has not entirely disappeared. Proper grinding is of great importance, not only because of economies in total cost of production, but because of the need of having the product finely ground, uniform in grain size, and of such a standard high grade that consumers may depend on it. With some methods of milling now in use it is impossible to maintain such high standards of quality, and the improperly prepared talc that is placed on the market not only injures the reputation of the producer but harms the entire industry. The output of inefficient mills is often marketed through brokers or jobbers who handle other minerals as well. A company desiring a small lot of talc to test its suitability for definite purposes may obtain poorly prepared material and finding it unsuitable may condemn all grades of talc.

In the design of a new talc mill undue weight should not be given to first cost, the claims of overzealous salesmen of machinery, precedent, or the process used by another talc mill. Low first cost of machinery may mean high upkeep, high consumption of power, or a poor product. Much unsuitable machinery has been installed as a result of too much reliance on claims of salesmen. A salesman's honest convictions may have an unconscious bias. Slavish adherence to precedent has frequently halted progress. The adoption of methods used in other mills has at times resulted unfortunately, either from poor methods in the original mill or from failure to recognize differences in the crude talcs.

#### FACTORS IN THE CHOICE OF MILLING METHODS.

The selection of proper milling machinery depends on the following factors: (1) Physical characteristics of crude ore, such as hardness, the presence and nature of impurities, moisture, structure—

massive, fibrous, foliated, or granular—and specific gravity; (2) availability and cost of power; (3) size of output and grades of product desired; (4) relation between the first cost of machinery and the costs of power and maintenance; (5) quality, quantity, and cost of labor.

#### PHYSICAL CHARACTERISTICS.

Talc is one of the softest minerals known, but fibrous talcs, like those of the Gouverneur district, which grade into tremolite, are much harder than most pure talcs. Compactness and the presence of impurities also increase the hardness. Some impurities, such as quartz, are so much harder than talc that in some methods of milling they remain in the finished product as coarse grit. By other methods of milling the harder impurities are either removed or are eventually ground as fine as the talc. Impurities, such as calcite or dolomite, though harder than talc, are easily ground. The quantity of physically combined moisture, or that which is driven off at 110° C., determines whether or not a drier is necessary. The moisture content of talc depends upon the mineral's absorptive power, the quantity of water that flows through the talc in the mine, and the method of mining and handling. Except the absorptive power, these factors may be modified by changes in mining practice. Structure is a very important factor both in milling methods and in utilization.

Pure massive or granular talcs are ground most easily; grinding fibrous or foliated talcs or a mixture of the two is much more difficult. Fibrous talcs are hard, are usually mixed with tremolite, and tend to grind into long needles rather than into rounded grains. Foliated talcs are soft, but they break up into thin micaceous plates that slip upon each other between grinding surfaces instead of being ground. A mixture of fibrous and foliated talc is not only hard to grind, but sizing by air separation is difficult because large thin flakes and long fine needles are suspended in the same current of air. The true specific gravity of pure talc is 2.55 to 2.78, but impurities may raise or lower it. The apparent specific gravity of ground talc depends somewhat on its structure, hard, compact, rounded grains seeming heavier than thin, flat flakes. Upon the specific gravity and structure depends the possibility of removing impurities by gravity separation.

#### AVAILABILITY AND COST OF POWER.

If water power or electric power can be obtained cheaply in large quantities, and if this condition will probably prevail for a considerable time, the item of power consumption by milling machinery may not be important, but if power is scarce and expensive this factor may be very important. In one large talc district power was formerly

cheap and plentiful, and in the design of talc mills little attention was given to power consumption. Now conditions have changed; the demand for power for other uses and the cost of power have increased. During 1920 the output of several mills was seriously curtailed from lack of power. If these mills had been designed for more economical power consumption, they might have run continuously at full capacity. The cost of power also may be a large item in the total milling cost.

#### SIZE OF OUTPUT AND GRADES OF PRODUCT.

The size of output contemplated and the grades of product to be made are interdependent. Some types of machinery are made in several sizes, so that almost any output may be obtained from one or more machines. But other machines, such as the Raymond roller mill, can not be made successfully in small sizes, and if a small production is desired another type of machine must be used. If several grades and sizes of finished talc are to be made, proper machinery must be chosen to produce these grades in the desired proportion. Some grinding machines will produce a large proportion of 300-mesh talc, others a smaller proportion, and still others, though giving a good percentage through 150-mesh, will give very little through 300-mesh. Many fine-grinding machines can be adjusted to give a large percentage of very fine material but with greatly reduced capacity. Such use of machines to produce a grade for which they were not designed is usually uneconomical.

#### RELATION BETWEEN FIRST COSTS AND FINAL COSTS.

Too often in the design of mills an effort is made to save on the first cost, which includes cost of the machines plus installation, at the expense of final cost, which includes interest on first cost, depreciation, repairs, and the operating costs of power and labor. The reverse may occasionally be true, where a very expensive plant is installed with a low upkeep when a much less expensive plant would give satisfactory results with only a moderate increase in cost of operation. The relation between first cost and final cost should be studied carefully before the ultimate design is decided upon.

#### QUALITY, QUANTITY, AND COST OF LABOR.

The nature of the labor supply available may have some bearing on the success of the methods adopted, as well as upon costs. If labor is scarce and expensive, or if such a condition seems probable in the future, labor-saving machinery should be used wherever possible. If labor is cheap but unskilled and inefficient, methods should be selected in which it is not necessary to exercise skill and alertness. In

one talc mill a process is used successfully, owing to careful supervision and to the intelligence of the labor, that probably would not be successful in other places. Where skilled mechanics are not available, complicated or unusual machines that require expert attention should not be used unless it is planned to bring in such mechanics.

#### LOCATION AND DESIGN OF THE MILL.

The choice of proper location and design for a talc mill has an important bearing on efficiency and cost of production. If the mill is to be on a railroad siding, the number of available sites is usually limited, but if it is to be built at or near the mine a wider range of choice may be possible. There has always been a controversy in the mining profession as to whether a hillside or the level ground is preferable. If a hillside is selected, material may be transported by gravity to a large extent, doing away with elevators and conveyors; but a greater number of floors is necessary, making supervision a little more difficult and possibly increasing slightly the necessary amount of labor. For most talc mills a hillside location is preferable.

The design of a grinding mill is highly important, and the employment of expert engineering advice will generally amply repay its cost. It is not uncommon to find modern, efficient machinery in a mill so poorly laid out that profitable operation is impossible. Improper design means undue rehandling, complicated systems of elevators and conveyors, increased cost of power and repairs, and frequent delays and shutdowns.

In a mill of proper design there is a straight flow of talc through the mill with a minimum of handling; modern, efficient machines are so situated that they may be driven from one or two main-line shafts with a minimum of belting or by individual motors, and efficient and economical operation results.

#### UNLOADING, SORTING, AND CRUDE STORAGE.

The methods used in unloading ore from the mine depend on the means of transportation from mine to mill. Ore may be dumped automatically from the skips into the mill bins; may be dumped by hand or automatically from mine cars; or the ore may be shoveled by hand from wagons, trucks, or railroad cars. Where ore comes in railroad cars, these should be of the bottom-dump type, if possible, and the tracks should be arranged on a trestle so that the cars may be dumped direct into the mill bins. At one mill the ore arrives in flat-bottom cars, is shoveled by hand into wagons, hauled less than a hundred yards to the mill, and unloaded by hand to the mill floor. This mill is small, but the expense of rehandling warrants the installation of a more economical method. At another mill where



ore arrives in railroad cars a track runs along the center line of a large rectangular concrete bin on the ground level. At one side of the bin, resting on its bottom, are jaw crushers used for primary crushing. Unfortunately, the track is so low that when the cars are dumped the ore can not run by gravity to the crusher, nor will it run to the sides of the bin; if the bin capacity is to be utilized, the ore must be shoveled back by hand. An attempt was made to make movable a section of the main track containing a loaded car, so that it might be shifted to a position immediately over the feed hopper of the crusher by means of a secondary crosswise track under the main track; but this device has not yet been successful on account of the great weight to be moved. Even if successful, the wisdom of this method of unloading would be questionable, as the crusher would be choked while the car was being dumped and running idle the rest of the time. The bin capacity here can not be utilized efficiently without extensive changes, involving the raising of the main tracks and the installation of a system of longitudinal and crosswise conveyors to bring the ore to the crushers.

Where ore sorting is not done at the mine and such sorting is desirable, provision must be made at the mill. If little sorting is necessary, the ore may be dumped conveniently on a grizzly or iron-bar screen set at a low angle. As the primary crushers usually make a 2-inch product, the bars may be spaced 2 inches apart and the grizzly undersize by-passed to join the crusher discharge or to go to a dryer. Dumping in this way will relieve the crusher and will also tend to segregate the wettest material; for the water is usually concentrated in the finest sizes. The coarser material left on the grizzly may be sorted into various grades, for which chutes leading to appropriate bins should be provided. The remainder of the material on the grizzly may then be pushed off into another bin. If the mill has large capacity and several grades are to be made by sorting, the crude rock might be unloaded directly into a receiving bin. From the bottom of this bin the ore could pass by an automatic feeder to a variable-speed picking belt or pan conveyor. Here the ore could be sorted into several grades and the material left on the belt allowed to drop into the feed hopper of a primary crusher. The picking belt would thus also serve as a variable-speed feeder for the crusher. The advantages of providing crushing and grinding machinery with a regular and uniform feed are now generally recognized.

Storage bins for crude ore are used by nearly all large producers, but they are as valuable to small producers. The bins should be large enough to hold a day's mill run, or more if possible; they should have sloping bottoms and should be so high that they may feed by gravity to a crusher or be provided with a system of conveyors to

gather the ore from the various bins. One mill is provided with eight crude-ore bins with a total capacity of over 1,800 tons. Four of these bins are for wet stock and four for dry; but they are further designated by the grade of ore for which they are intended. By a system of belt conveyors, ore may be conveyed from the bottoms of the bins to dryers or to a central assembling conveyor which feeds the primary jaw crushers. At another mill three 100-ton crude-ore bins are used, into which the mine cars may be dumped directly. One of these bins is usually reserved for storage of wet talc. Each bin has two discharge gates. In front of and below the gates is a belt conveyor 24 inches wide by 45 feet long, leading to the primary crusher. (Pl. III, A, p. 30) Detachable spouts are used which may be moved from one gate to another, so that the ore on the conveyor will not be impeded by overhanging spouts. As not all of the ore needs drying, the mill is run most of the time without the dryer. When the wet bin is full the dry feed is cut off and the dryer operated until the wet ore is disposed of.

At another mill, storage space is provided, but the handling is less efficient. Crude ore is brought from the mines in wagons or trucks and is shoveled by hand into a storage shed below the level of the road. Down the center line of the shed at a height of about 30 inches above the floor is a 12-inch belt conveyor, 40 feet long, leading to the primary crusher. (Pl. III, B, p. 30.) An additional 20-foot length of conveyor is attached when the shed is nearly empty. The ore must be shoveled from the stock pile, transported by hand, and loaded on the conveyor. As the shed is wide the feeding of the conveyor involves considerable labor when the shed is nearly empty. The entire system is inefficient, yet some effort could be saved by lowering one end of the conveyor.

#### FREEZING IN BINS.

If in winter the ore freezes in the bins, an expedient devised at a tripoli mill in Missouri might be adopted. Large steam pipes are placed in the inside of the bin, one ring near the bottom, one in the center, and one near the top. Exhaust steam from the engine is allowed to circulate through these pipes, so that the cost of steam is negligible. In this way enough heat is maintained in the bins to prevent freezing in the winter, and to have some drying effect during the rest of the year.

#### DRYERS.

Talc producers differ in their views on the economy or the necessity of using a mechanical dryer in milling. As it comes from the mine or quarry, talc may be in large lumps, which are free enough from moisture to pass readily and rapidly through the crushing and grinding machinery. Usually, however, some fine material is present,

which absorbs and holds moisture and reduces the efficiency and capacity of the grinding machinery.

#### EXAMPLES OF PRESENT PRACTICE.

Wet fines are handled in different ways in the Vermont district. At one mine, all material from underground is hoisted in a skip and dumped automatically over a 2-inch grizzly set at a low angle. The wet fines fall into one bin, and the coarse talc, after being picked, is spouted into another bin. The dry talc and the wet talc are hauled in separate cars to the mill, and there dumped into separate bins. Talc from the dry bins passes directly to a jaw crusher, whereas that from the wet bins goes first to a Barlett & Snow, or to a Ruggles-Cole dryer. The inner drum of the Ruggles-Cole dryer has been removed, making it direct heating instead of indirect. Coke is used as a fuel, so that the talc is not discolored by smoke and soot. With coke as a fuel the talc is so little discolored that the dust carried out by the forced draft may be collected and mixed with the ground talc without impairing its color in the least. From the dryers, the talc joins the discharge from the jaw crusher.

At another mine, the wet fines are screened out at the top of the shaft and dumped on piles of wet stock. As the surface of these piles dries out, the top material is shoveled off and hauled to the mill, where it is stored in long low piles under sheds until it is dry enough to grind.

At a third mine, a separation of wet and dry material is attempted underground. In mining the talc, raises from the drift are put up along the steeply dipping walls at intervals of about 50 feet. These raises are widened out into stopes and may be connected with each other by branched raises. Grizzlies made of wooden poles are often placed at the junction between two branched raises. These grizzlies have about 2-inch openings and are arranged so that the coarse material goes to one chute and the wet fines to another. In driving the drifts, the large pieces are loaded separately from the fines. In this way the dry rock and the wet are hauled separately to the mill, where they are dumped in separate bins. Ordinarily the mill handles the coarse, dry material, but when the bin full of wet fines has accumulated the dry feed is cut off, and the wet is run through separately. The dry and wet processes are alike in the initial and final stages, but differ in the intermediate stage. The crude talc is conveyed from the bins to a jaw crusher and is then elevated to a rotary screen with one-half-inch round holes. The oversize (either wet or dry) goes to a Sturtevant rotary crusher, thence, if dry, to stock bins; if wet, to a Ruggles-Cole dryer. The screen undersize, if dry, goes to the stock bins, but if wet, it goes to

the dryer. The dried material joins the dry crushed rock in the stock bins. The Ruggles-Cole dryer is of the indirect-heat type and is fired with bituminous coal.

At a fourth mill, no mechanical dryer or other means of drying is used. Great care is used in mining to keep the talc dry and to prevent water entering muck piles. Two-inch planks are laid close together in the drifts, raises, and stopes before each shot is fired. By this means water and iron stain from rails and pipes are nearly excluded, and shoveling is made much easier. Some wet material inevitably reaches the mill, but being mixed with dry rock it does little harm.

In all of the examples cited the talc is subsequently ground by emery mills, pulverizers, or roller mills, equipped with the Raymond system of air separation. The problem of drying is thus somewhat different from that at mills using tube mills.

At a mill in Canada where grinding is done in tube mills the use of a dryer has been found advantageous. Here the crude ore is first crushed to 2 inches in a jaw crusher and then to one-half inch in rotary crushers. The one-half-inch product is fed to two Cutler steam dryers. This type of dryer is unusual in talc mills, being originally designed as a corn dryer. Essentially it consists of a bundle of pipes, heated by low-pressure steam, set in circular headers that are revolved mechanically about an axis that has a slight inclination from the horizontal. The talc enters at one end and is cascaded around and between the hot pipes until it reaches the other end. The drying temperature may be regulated very closely, thus guarding against overheating, and there is no soot or ashes to contaminate the product. It has been found advisable to convey the dried talc for some distance in the open air before it is fed to the next machine. This allows evaporation of the moisture that has been driven out from the pores of the rock. In other types of dryer this moisture is carried away by the air and gases circulating through the dryer.

Dryers are not used in any New York talc mills, but in some mills dryers would probably increase efficiency in grinding.

The advantages of grinding only dry stock are evident and can not be denied, for wet material packs badly in bins, crushers, and grinders—reducing capacity and increasing labor charges—makes efficient air separation more difficult, and may lower the grade of the finished product. The relative economy of using a dryer or of air drying in heaps is not so evident. Screening and drying at the mine are expensive, slow, and inefficient, as the material must all be rehandled several times by hand. The drying is not uniform through the heap, and is very slow in rainy or cold weather. The advisability of using a mechanical dryer depends upon the follow-

ing factors: Ratio of wet to dry material as mined; percentage of moisture in wet material; cost and feasibility of excluding moisture underground; mill capacity; cost of drying.

If the proportion of wet to dry talc is very small, or if the average percentage of water in the wet is small, then it may be possible to eliminate drying by mixing the wet and the dry talc before crushing. If the walls and roof underground are seamy and water constantly drips from the roof, the use of planks for shoveling might not exclude the moisture and no feasible method might be found for keeping the rock dry underground; if planks or other means could be devised to keep the talc dry, then the cost of such protection must be balanced against the advantages gained, and against the cost of mechanical drying. A very small mill capacity might preclude the possibility of installing advantageously a dryer, irrespective of other factors. The cost of drying might be so low that the exclusion of moisture underground would not be worth while. In general, however, the cost of drying is an important, if not large, item.

#### BEST METHODS OF HANDLING WET FINES.

The ideal method of handling wet fines would probably combine some features of each of the examples cited. In a mine where the exclusion of moisture underground is feasible, the use of planks is advised, as this method obviates drying and increases efficiency in shoveling. For elimination of a small amount of moisture, mixing may be advisable. Mixing of crude stock will also increase uniformity of feed and of finished product, but has the disadvantage of making difficult the preparation of special grades from small lots of high-grade crude talc.

With proper precautions some mills could probably dispense with driers, but in producing finely ground talc the great advantage from milling dry stock should be considered. In large mills, where drying is not always necessary, a small drier should be installed, so that the mill would not be held up if it became necessary at any time to handle small tonnages of wet stock. In conjunction with the reserve drier it is well to consider the installation of enough auxiliary machinery to enable wet and dry stock to be milled simultaneously, instead of running dry and wet alternately. The relative economy of using a direct-heat drier fired with coke, compared to the use of an indirect-heat drier with coal, should be studied. The difference between the cost of coal and coke must be balanced against the increased fuel efficiency of coke and of directly applied heat, the freedom from smoke and soot, and the possibility of recovering fine talc carried out of the heater by forced draft. The possibility of using some type of a steam-heated drier should also be considered.

The crude rock may generally be screened and only the material finer than 2 inches dried. But in very wet mines, where the large lumps also absorb water, it may be necessary to crush all the rock to 2 inches and send it all to a drier.

#### PRIMARY OR COARSE CRUSHING.

Primary crushing at most talc mines is done in jaw crushers of the Blake type. These machines vary greatly in size, too small crushers being used at many mills, especially the small ones. Crushers should be large enough to break mine-run ore without excessive hand sledging and have enough capacity to supply all possible needs of the mill, even if run only part time. There is little advantage to be gained by economizing in the size of the crusher, for it usually results in excessive labor charges for sledging and in costly delays due to an inadequate supply of crushed rock. Crushers were observed varying in size from 12 by 8 inches to 36 by 30 inches. The 12 by 8 inch crusher was so small that most large pieces had to be broken up and fed by hand, the mill being shut down waiting for crushed rock a large part of the time. The smallest crushers that were at all adequate were 15 by 12 inches, but in designing new plants the use of larger sizes would probably be advisable. In order to provide small enough feed for a small crusher it is necessary either to use heavy blasts in the mine or do hand sledging. If heavy shots are used, the percentage of fines is increased, which in a wet mine will require drying. Thus for several reasons the use of crushers of adequate size will prove economical.

At a few mills no large-jaw crushers are used, but the rock is broken by hand small enough to feed to a rotary crusher. This practice is slow and expensive. No gyratory crushers were observed at talc mills, and it is doubtful if their use would be advantageous. Gyratory crushers for the same capacity have smaller feed openings, and they require more head room than jaw crushers. In addition, blocks of crude talc are often so smooth and slippery that it would be difficult for a gyratory to obtain a grip on them. Gyrotories are of advantage only where a very large capacity is desired and where the rock breaks naturally into long thin slabs, which tend to slip through a jaw crusher without being broken.

The approximate power requirements for Blake jaw crushers vary from 10 horsepower for a 15 by 9 inch to 60 horsepower for a 36 by 24 inch, but some reserve power should be provided.

The most common practice in primary crushing is to make a 2-inch product, but products ranging from one-half to 2½ inches are made. In general the 1½ to 2½ inch range should be observed, the exact size depending on the size of the crusher and the nature of the secondary crushing machinery. It is usually not good practice to

crush in primary crushers finer than  $1\frac{1}{2}$  inch, for the capacity of the crusher is reduced too much. If a finer product is desired, it is more economical to crush coarse and use secondary crushers.

#### SECONDARY OR INTERMEDIATE CRUSHING.

In secondary crushing a greater variety of machines is used than in primary crushing, for more types are available and not all types are adapted to every variety of talc. Machines of this class are generally used to reduce the coarse crushed rock ( $1\frac{1}{2}$  to  $2\frac{1}{2}$  inch) fine enough to feed to the fine grinding machinery one-eighth to 1 inch. The most common secondary crushers now used are rotary crushers of various sizes, but rolls are much used; in a few plants hammer mills and disintegrators, set to make a coarse product, were noted. Rotary crushers (Pl. VIII, A, p. 45) resemble gyratory crushers in appearance, but the central vertical shaft merely revolves instead of having an eccentric motion. These machines are built in various sizes with a varying number of grinding heads. An unusually large ratio of reduction may be obtained as the different grinding heads reduce fairly large lumps by successive stages to a moderately fine product. In order to obtain the same ratio of reduction with rolls, the material must be passed through two or three sets of rolls each adjusted to make a finer product than the one before. At one mill where  $2\frac{1}{2}$ -inch lumps were reduced to one-half inch by rolls, three sets were used. The first made a 1-inch product which went directly to a second set making a one-half-inch product, which was sized in a revolving screen with one-half-inch holes. The screen oversize was sent to a third set of rolls set to one-half inch. At another mill where secondary crushing was done in two stages, a rotary crusher followed a set of rolls.

One of the fundamental principles of milling is that it is cheaper to crush than to grind, but it is not economical to try to do fine grinding in machinery designed for secondary crushing.

It is always a good policy to make as fine a product as possible in secondary crushing. If this can not be done by one machine it may be done in two or more stages. If a two-stage reduction is used, a screen having openings the size of the final product desired should be placed between the crushers in order to remove from the first product all the material fine enough to pass the second crusher. This procedure follows out a second milling principle, that when material is crushed or ground fine enough for a particular stage it should be removed from the circuit, in order to lessen the load on the next machine and to make its operation more efficient. Fine material mixed with coarse cushions the crushing or grinding effect of any machine for the same reason that it is difficult to crack a nut resting on a pillow.

In mills having small capacity it may not always be worth while to observe this principle, but in large mills observance may be very important. For the secondary crushing of talc rolls are not usually as efficient as rotary crushers, especially in mills of small or moderate size, as the ratio of reduction obtainable with rolls is much less than with rotaries. Thus, where a given reduction may be made in one stage in a rotary, two or more stages may be required with rolls. Feed to rolls may not be much greater than  $1\frac{1}{2}$  inches in size, whereas rotaries take much larger feed. The ratio of reduction with rolls is ordinarily not much over 4 to 1; with a slippery mineral like talc it may be only 3 to 1.

The most common size of product made in secondary crushing lies between one-fourth inch and one-half inch, but extremes of one-eighth inch to 1 inch were noted. Where the secondary crusher product is to be used as feed to tube mills or pebble mills it is not necessary to crush as fine as where the fine grinding is done in roller mills, emery mills, or in some forms of pulverizers and disintegrators. Though some of the latter machines will take a coarser size of talc feed, nothing is to be gained by requiring a fine-grinding machine to do coarse or intermediate crushing.

In the group of intermediate crushers certain machines should be noted that may be used either for secondary crushing or fine grinding, or for both. To this type of machines belong the various kinds of swing-hammer mills, disintegrators, and pulverizers, two of which are illustrated in Plate IV, *A* and *B* (p. 31). These mills are ordinarily not designed for grinding much finer than 100 or 150 mesh, but in grinding to that fineness a certain quantity of material 200-mesh and finer is produced which may be removed as a finished product by air separation.

Machines in this class may have an important application to the milling of talc when definite properties are desired in the finished product. For example, one talc mill has a good market for relatively coarse grades—that is, 20 to 100 mesh. These grades are made by grinding in a pulverizer equipped with a throw-out device which can be set to discard any size of product. The finely ground talc is removed and separated by an air separation system, and the coarser material, thrown out, is screened into finished products and over-size, the latter being reground. Another use for pulverizers equipped with a throw-out device is for the separation of hard granular material from a relatively soft, easily pulverized material. This system is used successfully for the separation of hard cores from hydrated lime and for the purification of ground phosphate rock.<sup>11</sup>

<sup>11</sup> Rock Products, Cleaning phosphate with air, vol. 23, Oct. 9, 1920, pp. 44-45.



Talc or pyrophyllite containing small rounded grains of quartz could be milled by first disintegrating it in a hammer mill that breaks up the talc but has little effect on the quartz. By further reduction in a pulverizer with a throw-out the talc would be ground to a finished product and the silica with a little coarse talc discarded as waste. If products of the requisite purity and fineness were not made by this method, or if too much talc were thrown out with the quartz, either of the pulverizer products could be put through a second machine for final cleaning. Pulverizers, hammer mills, and disintegrators can also be used for rather soft material to produce a feed for a subsequent fine-grinding machine.

### FINE GRINDING.

#### FACTORS IN FINE GRINDING.

The selection of the proper type of fine-grinding machinery involves a consideration of many factors, of which the following are the most important:

1. Physical properties of talc to be ground and of the impurities in it.
2. Required hourly production of mill.
3. Grain size and shape of product desired.
4. Intended uses for product and objectionable impurities for each use.
5. Cost and nature of power and labor.
6. Cost and quality of fuel (for drying the product if ground wet).

Determination of these factors greatly reduces the range of suitable fine-grinding machinery.

All fine-grinding methods may be divided into two general classes—dry and wet. As the wet grinding of talc, at least in the United States, has not been practiced on a commercial scale it will be considered only briefly. Dry-grinding methods were first developed from the methods used in the milling of flour. The first talc mills were converted flour mills and used horizontal buhrstones, followed by silk bolting reels. At least one mill exists to-day in which grain and talc are both ground in the same machines. A few other mills are in operation that still use the old-fashioned buhr mills, and silk bolting reels have not entirely disappeared.

#### BUHR MILL.

A buhr mill consists mainly of two circular abrasive stones superimposed, one on the other, in a horizontal position. (See Pl. V, *B*.) To one of the stones is attached a vertical shaft, through which

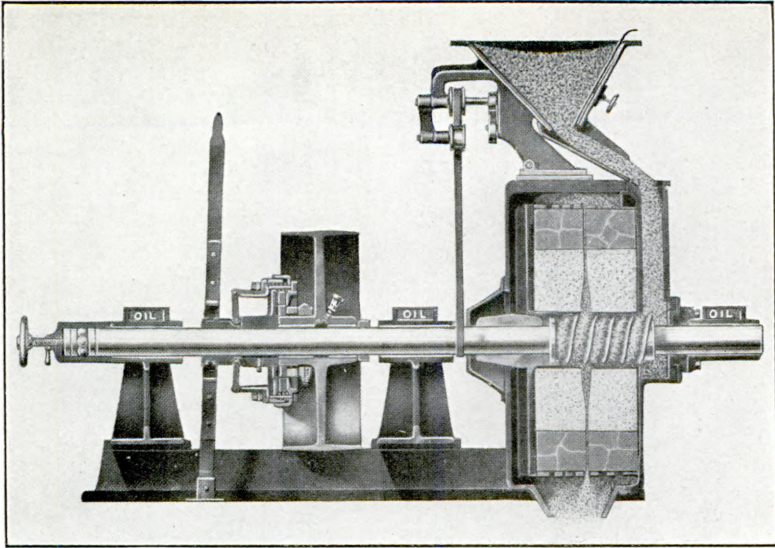

A. VERTICAL EMERY MILL.

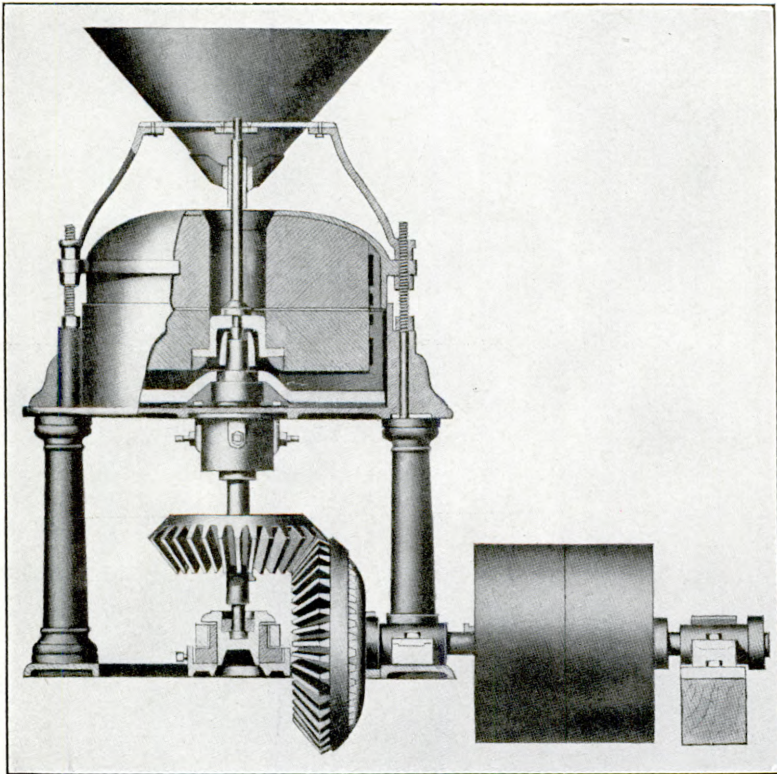

B. UNDERRUNNER BUHR MILL.

Generated at University of Michigan on 2023-02-13 11:27 GMT / https://hdl.handle.net/2027/uiug-30112104112039  
Public Domain, Google-digitized / http://www.hathitrust.org/access\_use#pd-google

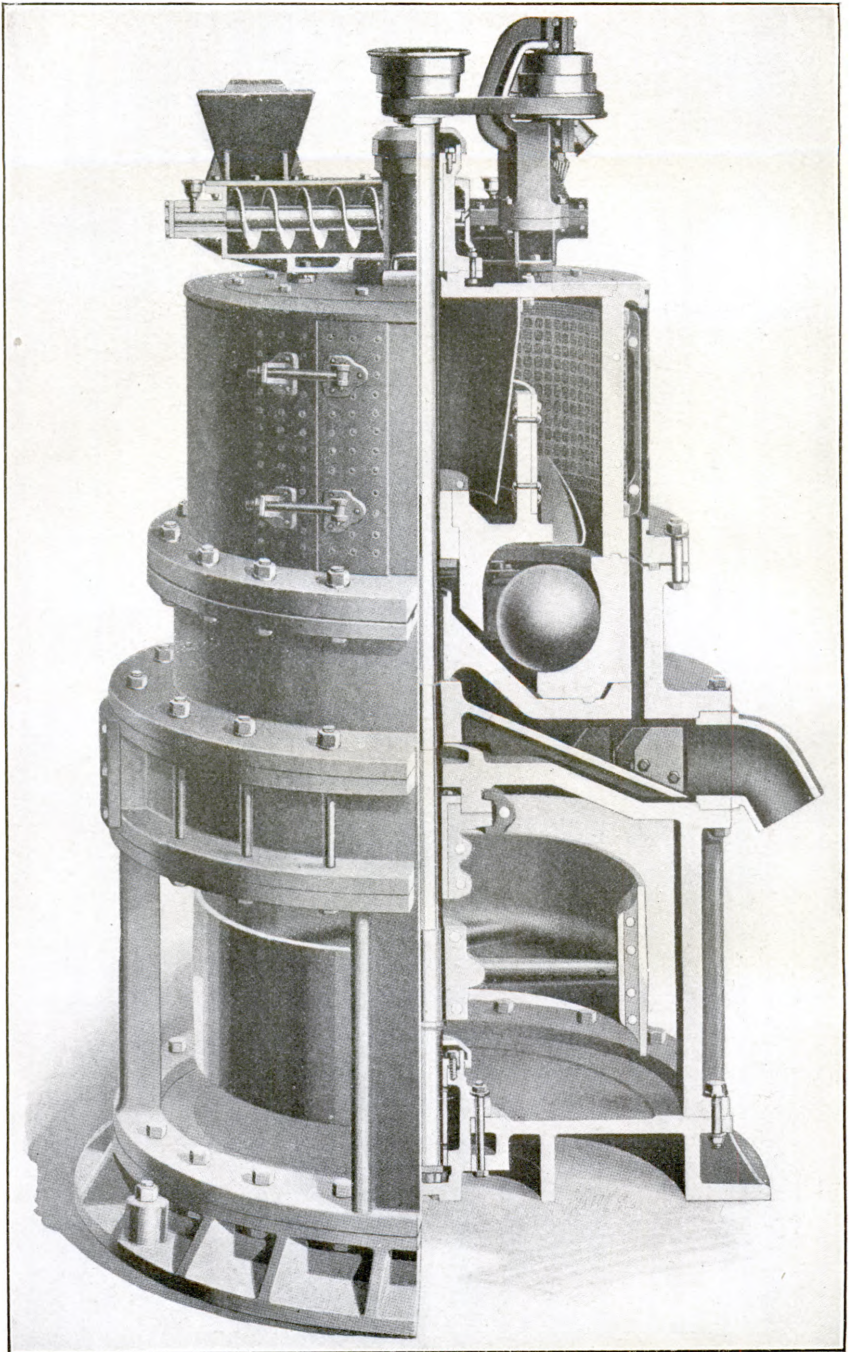

FULLER-LEHIGH MILL.

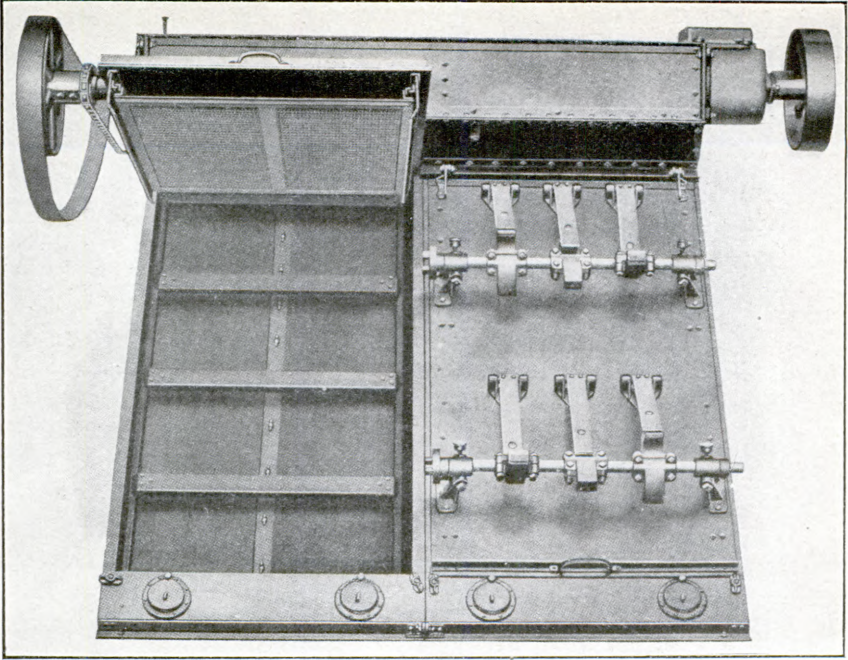

A. NEWAYGO SCREEN.

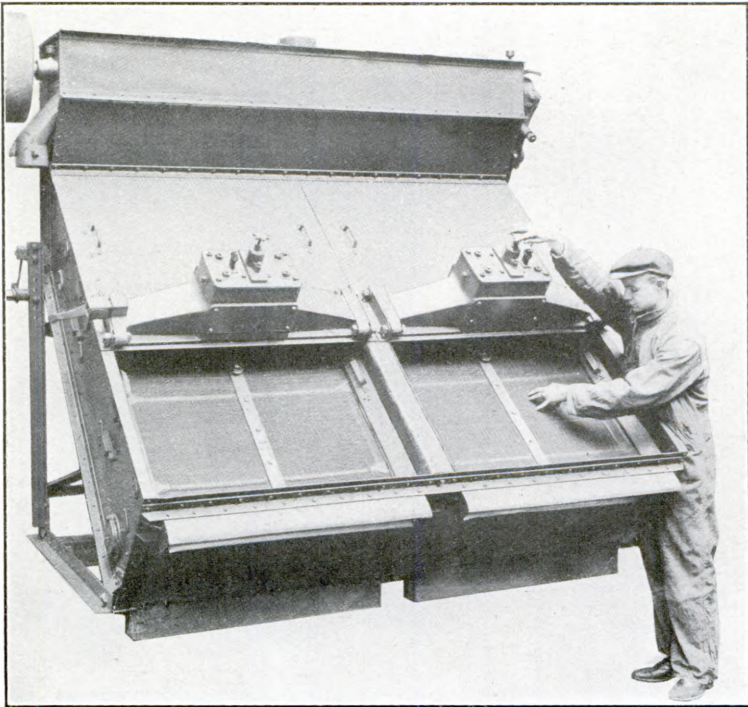

B. THE TYLER HUMMER SCREEN.

Generated at University of Michigan on 2023-02-13 11:27 GMT / <https://hdl.handle.net/2027/uiug-30112104112039>  
Public Domain, Google-digitized / [http://www.hathitrust.org/access\\_use#pd-goo](http://www.hathitrust.org/access_use#pd-goo)

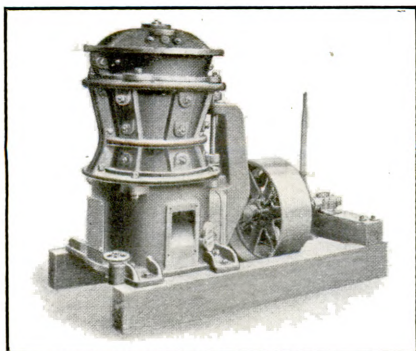

A. ROTARY CRUSHER.

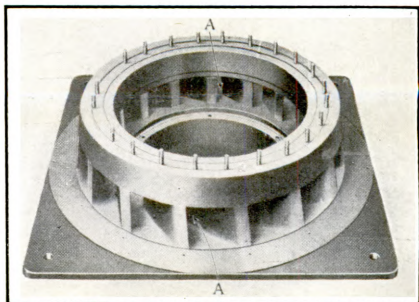

B. BASE CASTING OF RAYMOND ROLLER MILL.

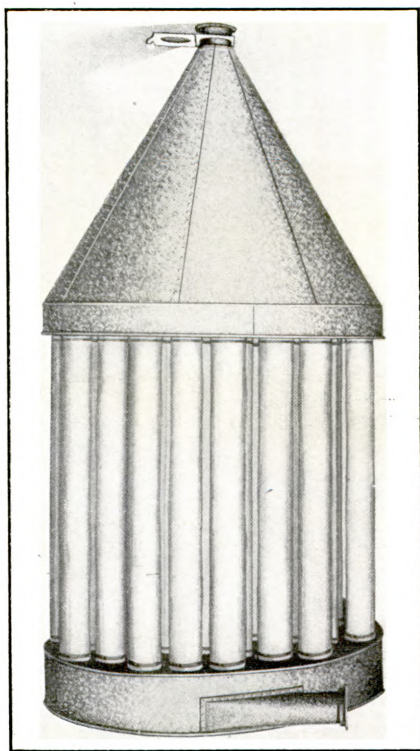

C. RAYMOND CYCLONE DUST COLLECTOR, TUBULAR TYPE.

power is transmitted, causing the stone to revolve. Either the upper or the lower stone may be made to revolve, the other remaining stationary, but the underrunner mill is the more common. In this type the feed is admitted through a hole or eye in the center of the upper stone and is distributed by centrifugal force over the grinding surfaces. Nearly radial slots or grooves of varying depth are cut in the stones to assist the passage of the material from the center to the periphery of the stones. The ground material drops off the edge of the lower stone and flows from the mill through a spout.

The stones usually consist of French buhr, which is a hard, siliceous rock especially adapted for grinding. Stones 36 to 42 inches in diameter were commonly used in talc milling. These mills are slow, have small capacity when making a fine product, and require much labor in dressing the stones. An improvement on the old-fashioned buhr mill has been made by substituting rock emery, a harder substance, for either the whole buhrstones or for the outer segments which wear down most rapidly.

#### VERTICAL EMERY MILL.

The vertical emery mill (see Plate V, A) is a further improvement on the original buhr mill. The stones are supported in a vertical position on horizontal shafts; one stone runs loose on its shaft, and the other is revolved rapidly. The feed is led in to the center of the stones by a spiral feeder attached to the moving shaft, and is thrown out between the stones by centrifugal force. The fineness of grinding and the pressure between the stones may be regulated by adjusting a screw on a thrust bearing on the end of the moving shaft. This mill revolves at a speed approximately twice that of the horizontal emery mills. Stones from 30 inches to 36 inches in diameter are most common in the talc industries. For some types of talc this machine, equipped with air separation, is being used successfully.

#### DISINTEGRATORS, PULVERIZERS, AND HAMMER MILLS.

Disintegrators, pulverizers, and hammer mills of the types previously described are sometimes used for fine grinding. Some of the devices can be adjusted so as to produce a fair tonnage of 200-mesh product when grinding a soft talc. They must always be used with an air-separation system or bolting reels when grinding finer than 100-mesh. Where there is no market for the coarser material rejected by the air separators or reels, it may either be returned for regrinding or, if the impurities are concentrated in it, discarded as waste.

## THE RAYMOND ROLLER MILL.

The material to be ground, crushed to one-fourth-inch to  $1\frac{1}{2}$ -inch size, according to physical properties, is fed to a mill from a storage bin through the spout S into the automatic feeding mechanism F, which delivers it in the proper quantities to the grinding chamber G. Here it is caught by the manganese-steel plows P and thrown up between the rollers R and the pulverizing or bull ring B. One of these plows is located just ahead of each roller, so that a constant stream of material is forced between the rolls and ring. (See Fig. 1.)

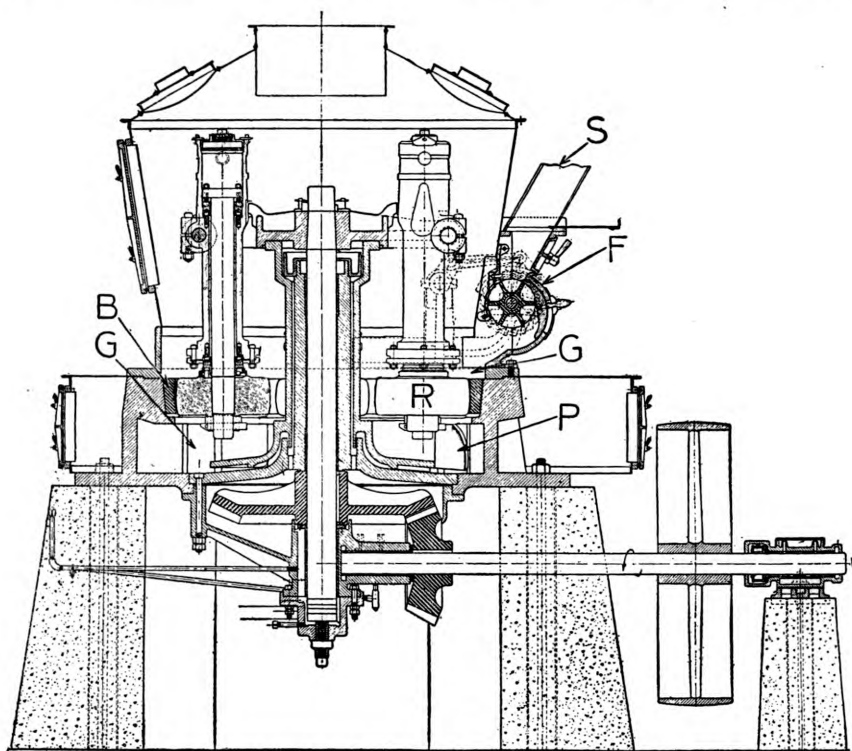

FIGURE 1.—Cross section of the Raymond roller mill. For explanation of lettering, see text.

The constant stream of air drawn through the mill by the air-exhaust fan separates the finely ground material from the coarser particles. The stream of air enters the mill through a series of tangential openings around the base of the grinding chamber and passes upward around the roller R and the bull ring B. In passing up it carries with it into the separator the finely pulverized material from the grinding chamber. The coarser and heavier particles fall back and are thrown up by the plows P to be reground until reduced to the desired fineness. No fine material remains in the grind-

ing chamber to clog the mill and to prevent continuous operation on coarse material. (Further discussion of air-separation equipment appears on p. 52.)

#### THE FULLER-LEHIGH MILL.

The Fuller-Lehigh mill (Pl. VI, p. 45) is made in several types but the grinding and sizing principles are similar in each type. The feed, crushed to three-fourths to 1 inch, enters the mill through an automatic feeder at the top and drops into the pulverizing zone. The pulverizing element consists of four unattached steel balls that roll in a stationary, horizontal, concave grinding ring. The balls are propelled around the grinding ring by means of four pushers attached to four equidistant horizontal arms forming a part of the yoke, which is keyed direct to the mill shaft. The material discharged by the feeder falls between the balls and the grinding ring in a uniform and continuous stream, and is reduced to the desired fineness in one operation.

By means of a fan driven from the main shaft, the finely pulverized material is lifted from the grinding zone into a chamber above and there is held in suspension. A second fan, acting as an exhaust, draws the finely divided particles through the finishing screen, which completely encircles the separating chamber, and down into the fan housing, whence it is discharged through a spout by the air pressure.

In order to make a more finely pulverized product, another type of this mill uses a secondary or auxiliary separating section between the grinding chamber and the screening section. Still another type utilizes an air-separating element which is an integral part of the machine itself.

#### TUBE MILLS.

Tube mills, in this discussion, include not only tube mills proper, but all the various forms of ball mills, pebble mills, dump cylinders, and conical mills in which the grinding is done by pebbles or balls in revolving cylinders or cones.

#### THE DUMP CYLINDER.

Probably the intermittent-dump cylinder is the oldest form of tube mill used for milling tale, and it is still found in some mills.

A typical dump cylinder consists of an iron or steel cylinder about 6 feet in diameter by 8 feet long, supported so that it revolves about a horizontal axis; it is lined with porcelain or silex brick, and is fed and discharged through an opening in the shell midway between the ends. The mill is loaded with a definite charge of flint



pebbles, a weighed charge of talc is admitted, a cover is clamped over the feed opening, and the mill is revolved for several hours until the grinding seems to be complete. Then the mill is stopped and a sample is tested; if satisfactory, the charge is ready for dumping. A grid or coarse screen is clamped over the feed opening to hold back the pebbles, and the cylinder is revolved slowly until all the talc is discharged into a hopper below the cylinder. The time of grinding, the weight and size of pebbles, the weight of talc charged, and the speed of revolution vary with the talc and with the ideas of the operators, but typical data for a fairly hard, fibrous talc are as follows: Charges, 1 ton of talc and 3 tons of Danish flint pebbles; speed of revolution,  $22\frac{1}{2}$  to 23 revolutions per minute; time of grinding, 4 to 7 hours. Grinding in dump cylinders is slow, requires considerable labor, and does not produce a uniform product mechanically. It is not to be recommended for a steady production of talc but may be useful for experimental purposes or for grinding small batches of special grades.

#### THE CONTINUOUS TUBE MILL.

The tube mill proper is used chiefly in New York State for grinding fibrous talc and fairly hard granular talc. There the typical tube mills are steel cylinders 6 feet in diameter by 24 feet long, lined with either silex or porcelain brick, and charged with flint pebbles. The talc is automatically and continuously fed through an opening at one end of the tube, and is discharged continuously through a similar opening at the other end. The axis of the mill is set at a slight inclination from the horizontal, so that the talc slowly traverses the length of the cylinder by gravity, assisted by the rotary movement of the mill. A capacity of nearly 2 tons per hour is obtained in one plant with a power consumption of 106 to 108 horsepower. As the starting load is heavy, a 150-horsepower motor is used to drive mills of this size.

One company uses four 6 by 24 foot tube mills in tandem without any system of screening or air separation to size the final product. In this plant nearly 500 horsepower, continuous load, is used by the tube-mill system alone for a product of slightly less than 2 tons an hour.

The use of the long tube mill without screening or air separation has proved very inefficient. Hardinge<sup>12</sup> says:

As concrete evidence of the great waste of energy in the long tube mill, operating in open circuit, a test was run several years ago on talc in a 6 by 26 foot tube mill. Samples of the material in the mill were taken at intervals

<sup>12</sup> Hardinge, Harlowe, Improvements in dry grinding: *Rock Products*, vol. 24, June 18, 1921, pp. 16-17.

throughout its length; a screen analysis of each sample was made, and the percentage of the total grinding calculated. A curve plotted between, "Percentage of total grinding," and "Distance from feed end in feet," is shown in Fig. 2. The result is startling.

By reference to this curve, it is evident that over 80 per cent of the total grinding is accomplished within the first 5 feet of length of the tube mill, or, in other words, the balance, or 20 per cent of the total grinding, consumed more than 80 per cent of the total power.

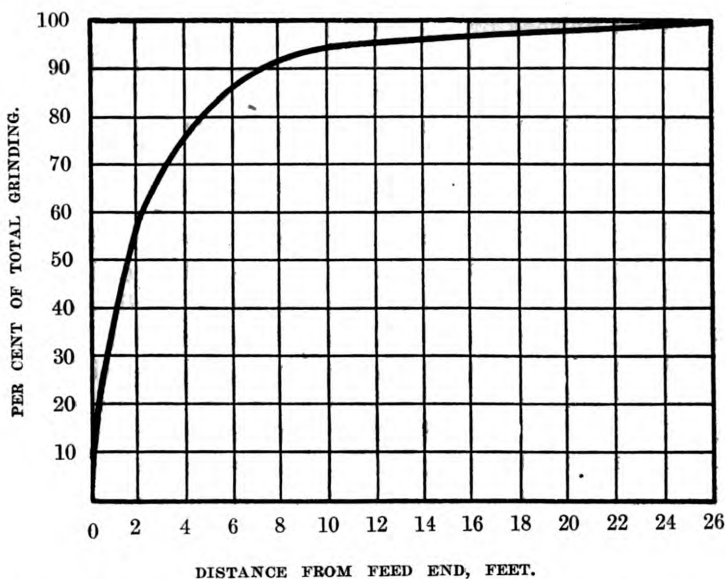

FIGURE 2.—Curve showing amount of total grinding accomplished at different points in 6 by 26 inch tube mill pulverizing talc.

If the mill were cut off at the 5-foot section and operated as before, the product would have to be ground to within 20 per cent of the fineness required. This product would be unsatisfactory, but if an adequate sizing device were employed and the oversize or partially ground material returned to the mill for regrinding, the product from this combination would be satisfactory. It has been found that short pebble or ball mills are far more economical to operate in the majority of cases in conjunction with air separators or screens than a long tube mill in open circuit.

Some operators contend that the short mill does not produce a sufficient amount of "impalpable" powder. This is true unless the short mill is operated in closed circuit with some type of sizing device. Then even more extremely fine material can be produced, as the regulation is positive and the cushioning effect is reduced. It is the very great cushioning effect of the finished material in the tube mill which is the main cause for its low efficiency. The grinding media do not get a chance to do effective work. It is just like trying to pulverize sea sand on the beach by pounding it with a hammer, without putting any hard substance underneath to prevent the sand from spreading out and dissipating the energy without obtaining any appreciable result.

Thus the inefficiency of using four long tube mills in tandem with no screening or air separation between or following them is very evident.

#### THE SHORT TUBE MILL.

The short tube mill has been adopted by one producer to eliminate the inefficiencies of the long tube. Several 5 by 8 feet tube mills are used, each followed by an elaborate system of bolting reels. These reels make a finished product, and an oversize product that is either returned to its tube mill or is sent to a similar regrinding tube mill. In this way the finely ground talc is removed almost continuously, leaving the mills free to grind the coarser particles.

#### THE HARDINGE MILL.

The Hardinge conical mill is being used by several talc producers as a primary fine grinder. Its action is similar to that of a very short tube mill, but its conical shape causes a grading or sizing of the grinding pebbles or balls, so that the coarser pebbles act on the feed and the finer pebbles on the partly ground material. The conical mill has been found very efficient for wet fine grinding, but is not yet used in the talc industry to make a finished product. One producer uses two Hardinge mills in series to produce a feed for dump cylinders. Another producer, in a recently erected mill, uses a Hardinge mill followed by an air separator, from which the material coarser than 150-mesh is returned to the Hardinge for regrinding, and the product finer than 150-mesh is used as a feed for a single 6 by 24 foot tube mill.

#### SCREENING.

Talc, as ground for most uses, must be separated into different products by sizing between two screens or by limiting the maximum size of the very finely ground product by bolting or air separation. Efficient milling further necessitates screening at various stages in the crushing and grinding process in order to prepare material for the feeding crushers and grinders.

#### GRIZZLIES AND TROMMELS.

As previously noted, the feed to crushers and grinders should be sized in order to remove coarse material which is too large for feeding to crushers or grinders, and to remove fine material, which reduces grinding efficiency by cushioning and reduces grinding capacity. Screens for removing coarse material are often used only before the first coarse crusher. Sometimes an iron-bar screen or grizzly

with bars spaced 4 to 8 inches apart is used either above or below the crude-storage bin. Large lumps retained by the grizzly bars are broken up by sledging, so that all the crude ore is of a definite maximum size when it goes to the crusher. Screens are also sometimes used after rolls to remove oversize, which is returned to the rolls for regrinding. For this purpose rotary screens or trommels are generally used.

#### IMPACT AND VIBRATED SCREENS.

For the separation of coarsely ground products—that is, 20 to 120 mesh, such as some of the roofing grades of talc—the use of some form of inclined, impact, or vibrated wire-cloth screen is very efficient. Of the impact screens the Newago is typical and is found most often in talc mills (see Pl. VII, *A*, p. 44). In this type of screen the screening surface is vibrated by impact hammers, the intermittent tapping of which is transmitted to screen wires stretched taut.

A more recent modification of the impact screen is the continuously vibrated screen, a typical example of which is the Tyler Hummer (Pl. VII, *B*). In this a constant vibration is produced by an electromagnet, and is applied directly to a taut, “drum-head” tension, screening surface. The intensity of the vibration may be varied while the screen is in use.

#### BOLTING REELS.

For sizing very fine, dry ground talc there are but two alternatives, bolting through silk or wire bolting cloth and air separation. Until the invention of the air-separation process bolting reels were in common use. Bolting reels resemble revolving screens or trommels, except that the frames are generally made of wood and the screening surface is more commonly composed of silk bolting cloth or “grit gauze.” They are used but little to-day in the talc industry, although for exceptional purposes they seem to be satisfactory. The principal claim made for the bolting reel is that the sizing of the product is more definite and accurate than with air separation. This claim may be true when the cloth is new; later, unless very careful watch is kept of the condition of the cloth, holes appear that allow comparatively large oversize material to slip through into the finished product. The main disadvantages of bolting reels are their small capacity, the high cost of bolting cloth, the rapid wear of the cloth, allowing contamination of product and causing high maintenance costs, and the impossibility of sizing finer than 200-mesh economically.

The main causes for the rapid wear of the cloth are overloading the bolting reel, and the presence of sharp grains of silica or other impurities. The latter trouble is not easy to remedy, but overloading

may be obviated by providing a large number of reels and feeding each one lightly. When milling a pure, soft talc it may be possible to get rather successful results by using plenty of reels, and by constant watch for the development of holes in the cloth.

#### AIR SEPARATION.

The best sizing methods to-day make use of some form of air separation. This process depends upon the lifting power of a current of air, and upon the interplay between centrifugal force and gravity upon particles in a circular or spiral air current. The two air-separation systems in most common use in the talc industry are the Raymond and the Emerick; other types in use are either home-made or are modifications of the principles used in these systems.

#### RAYMOND AIR-SEPARATION SYSTEM.

The Raymond air-separation system is really a part of the Raymond mill. In fact, the grinding action of the mill is dependent upon and inseparable from the air-separation system. Kanowitz<sup>13</sup> has given the following excellent description of this process.

By air separation we mean genuine air separation and not air conduction. There are processes which use air to handle the ground product. In some of these the material is sucked out by a fan and in others the discharge passes to a mechanical separator instead of to screens.

A real air separator should be an integral part of the mill. It should be able to remove the ground material from the grinding surfaces just as fast as it is made, thus preventing the mill from clogging. This increases the capacity of the mill, as it permits the rolls to grind on coarser particles. This can only be accomplished by having the air enter underneath the grinding surfaces and blow the ground particles up and away from the rolls.

The separator should be dustless in operation. It should be able to maintain a uniform product irrespective of changes in air velocity or air density met with under operating conditions. Should it become necessary to change the fineness of the finished product, it should be so designed that this can be accomplished in a short time and without shutting down the equipment.

Plate VIII, *B*, shows air-inlet ports, *A*, beneath the grinding chamber of a Raymond mill. Plate IX shows a view of a typical installation, a cross-section of which is shown in Figure 1 (p. 46). In Plate IX it will be noted that after the material has been ground and separated it is drawn into the fan and then blown into a cyclone dust collector. The material after traveling in the comparatively small sectioned discharge-pipe enters the large sectioned collector and is compelled to travel in a circular path; the centrifugal force thus produced causes the material to hug the walls of the collector and eventually drop through the bottom as finished product. The air being freed from the material passes up through the top of the collector into the return-air pipe, which delivers the air back to the portholes under the grinding chamber, shown in Plate VIII, *B*. These ports are surrounded with an air-tight casing, as shown in Plate IX.

<sup>13</sup> Kanowitz, S. B., Principles and practices of air separation: Rock Products, vol. 23, April 10, 1920, pp. 34-37.

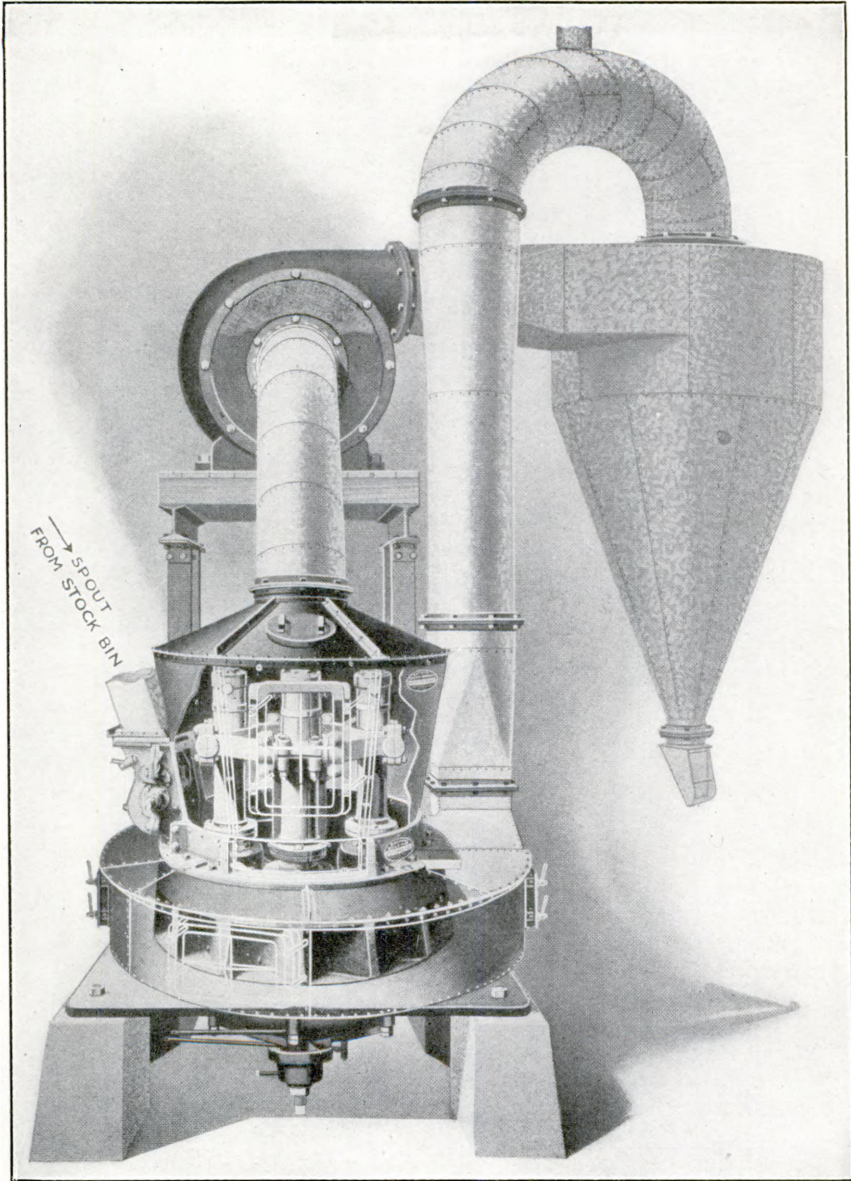

RAYMOND FOUR-ROLLER, LOW-SIDE MILL WITH EXHAUST FAN AND CYCLONE DUST COLLECTOR.

Generated at University of Michigan on 2023-02-13 11:27 GMT / https://hdl.handle.net/2027/uiug-30112104112039  
Public Domain, Google-digitized / http://www.hathitrust.org/access\_use#pd-gooole

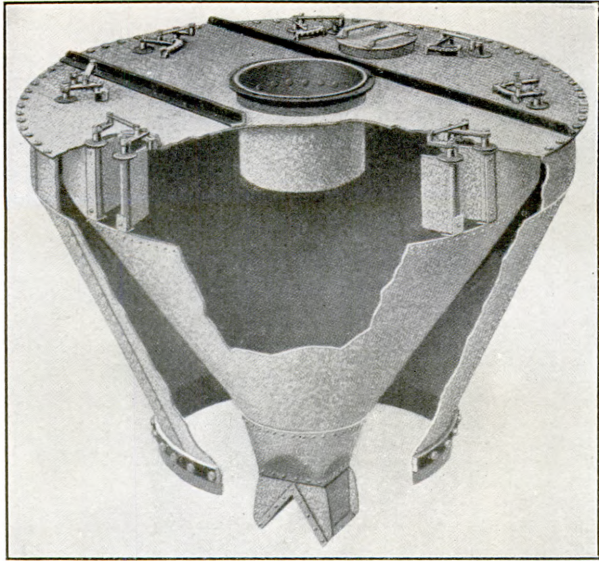

A. RAYMOND MILL, VACUUM SEPARATOR.

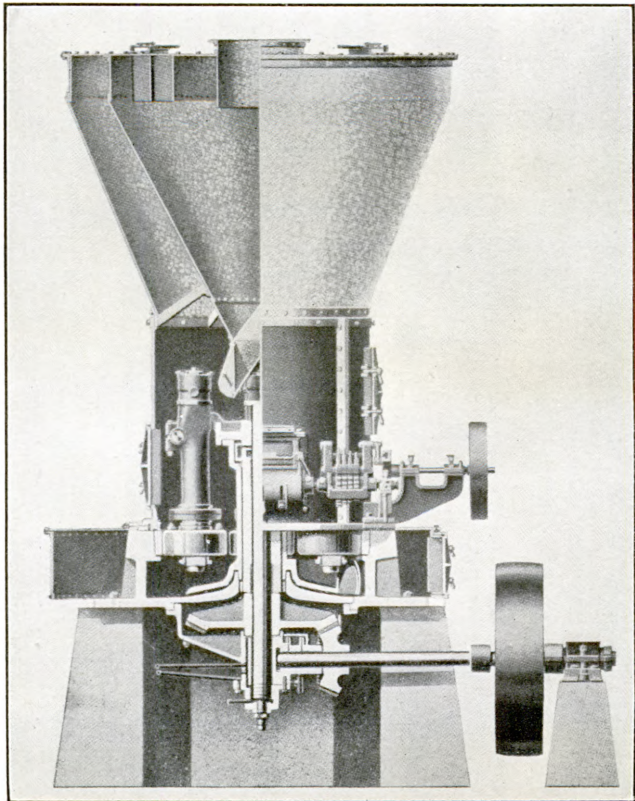

B. SECTION OF RAYMOND HIGH-SIDE ROLLER MILL AND SEPARATOR.

Generated at University of Michigan on 2023-02-13 11:27 GMT / https://hdl.handle.net/2027/uiug-30112104112039  
Public Domain, Google-digitized / http://www.hathitrust.org/access\_use#pd-google

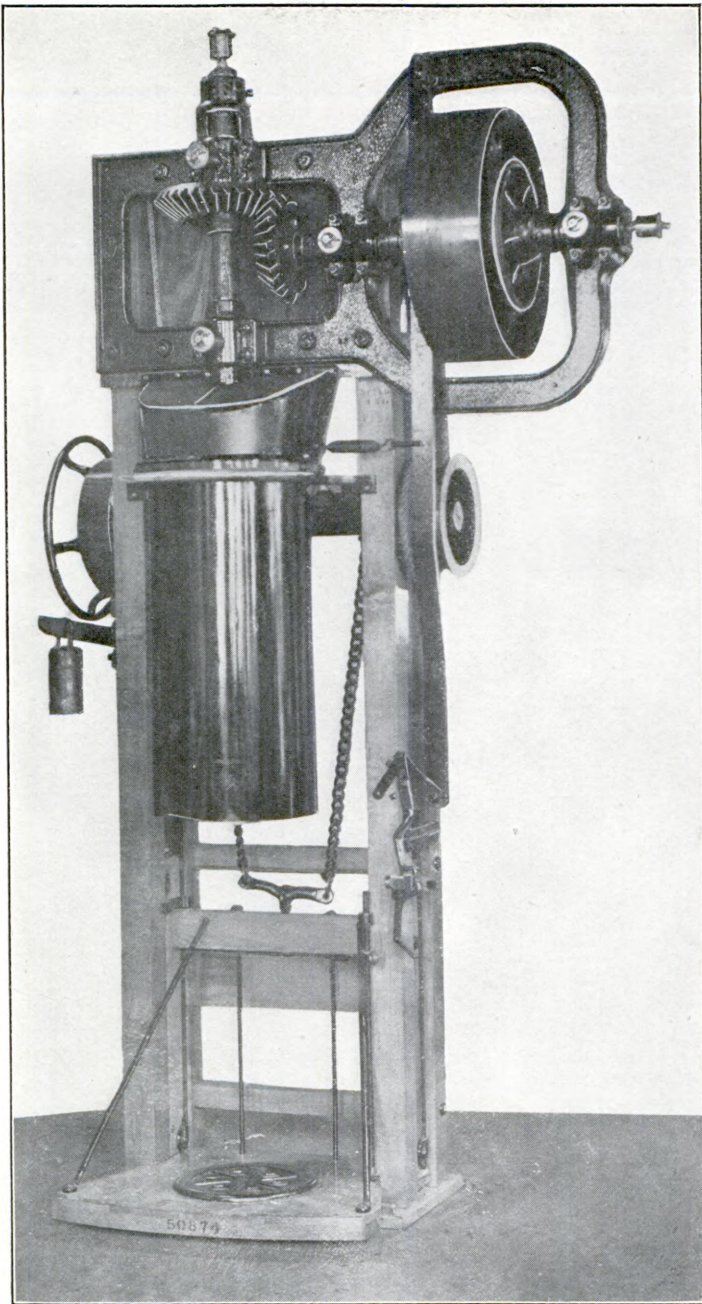

HOWES TALC PACKER.



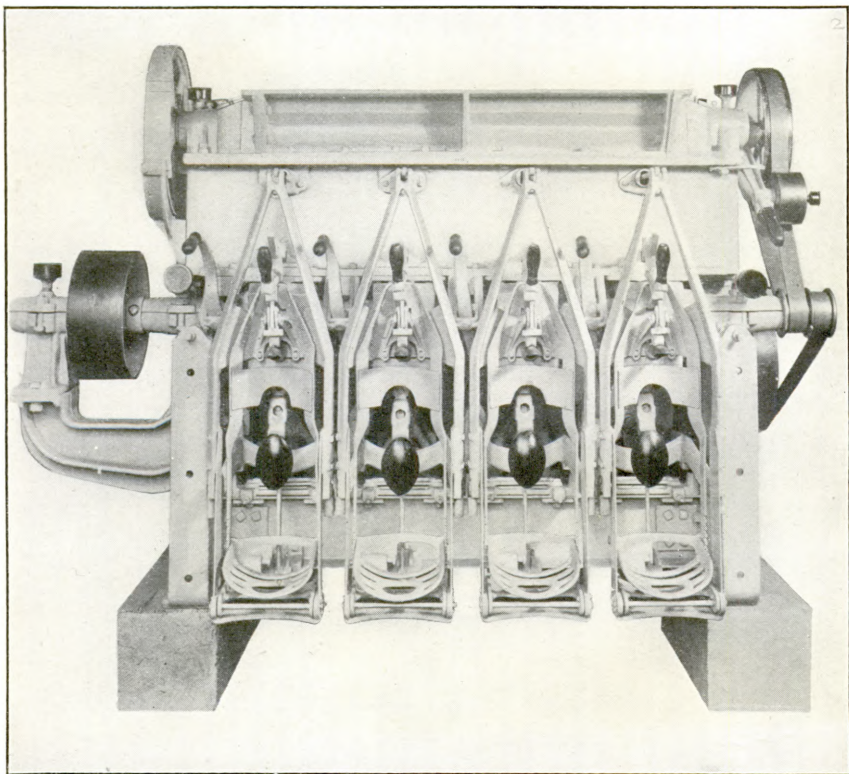

BATES VALVE BAGGING MACHINE.

Generated at University of Michigan on 2023-02-13 11:27 GMT / https://hdl.handle.net/2027/uiug-30112104112039  
Public Domain, Google-digitized / http://www.hathitrust.org/access\_use#pd-google

Just as soon as the rolls pass over the material the air takes it away, lifting it up, at the same time imparting to the material a whirling or circular motion. As the material passes up with its cyclonic motion, the whirling currents travel in a larger and larger circular path, due to the increased radius of the separator, the coarser particles, due to the action of centrifugal force, are constantly being thrown against the sides of the separator and drop back to the mill to be reground, while the finer particles upon which the centrifugal force is not great enough to overcome the fan suction, pass into the fan intake.

This type of separation is used with what is known as the low-side mill (Fig. 1, p. 46). It is adapted for medium grinding; that is, for material ground so that 85 to 95 per cent passes through a 100-mesh sieve. It will be noticed that the separation obtained is not done by changing the air velocity or air density, but by imparting a circular motion to the particles, lifting them up with a cyclonic motion, and as the separator increases in diameter and the air increases in rarity the coarser particles keep on dropping back to be reground. We can thus safely use a high-air velocity and lift up both coarse and fine, keeping the grinding surfaces free from fines and gradually, due to the cyclonic motion of the particles, separate the fine from the coarse and throw the coarse out of the air current back to be reground.

#### VERY FINE SEPARATION.

When a still finer product is required, or where it is desirable to frequently change the fineness, the high-side mill is used. The grinding mechanism of a high-side mill is identical to that of a low-side mill, the only difference being that in a high-side mill a double-cone separator is used, while in a low-side mill the single cone is used. The material is ground and removed from grinding surfaces in a similar manner in both mills.

In the high-side mill the material, after being subjected to the same mode of separation as in the low-side mill, receives a further separation by passing up between two cones and into an inner cone where it receives any degree of separation desirable. Plate X, *B*, shows the high-side mill.

The material after passing up between the two cones passes into the inner cone through ports, on the inside of which are fastened deflector vanes. The double-cone separator with the ports and deflector vanes is shown in Plate X, *A*. The deflector vanes can be rotated by means of a dial on top of the separator, so that the angle of ingress of material can be varied. This angle can be changed through minute degrees from a radial position (pointing straight toward fan intake) to an extreme tangential position.

When the material enters the inner cone, a certain per cent of the larger particles will drop out of the air current, due to the expansion of the air within the inner cone. As we wish to increase the fineness of the finished product, we set the deflectors so that the materials enter the inner cone at an angle. This will cause the material to travel in a circular path, producing a further cyclonic action; more and more particles will be thrown out of the air current against the inner cone and drop back through flap valves to the mill to be reground. The mechanism of this is shown in Plate X, *A*.

If a finer product is desired, the angular position of the deflectors is increased, which increases the cyclonic action, and the material is forced to travel in a path farther and farther away from the fan intake, so that the centrifugal force acting on the particles continues to overbalance the suction force of the fan, thus making more and more particles drop out; the finished product becomes finer and finer until when the deflectors reach their extreme tangential position so much material will be thrown out that the material entering the fan intake will be exceedingly fine.

The position of the deflectors can be changed by the operator in a very short time, while the mill is running, and any degree of fineness obtained without losing any time, due to a shutdown.

The operator soon finds out what position of deflectors will give the required fineness for any particular material. Having once found the required position for a certain material, he can indefinitely leave the deflectors in that position; the separator will automatically take care of his fineness. The only time he will have to change the position of the deflectors will be when he changes from one material to another having different physical characteristics.

#### THEORY OF AIR SEPARATION.

From what has been written above it will be seen that the fineness of the finished product depends upon the centrifugal force acting on the particles that will be rejected. The rarer the air the finer will be the finished product, since as the vacuum in inner cone increases the buoyancy of the air decreases and so loses its carrying capacity.

We will now assume that the material in the inner cone is revolving, due to the cyclonic action produced by the high air velocity. Each particle is acted on by two forces—the centrifugal force due to the velocity of its rotation and by the central radial force due to the fan suction. Those particles which are so small that the central force overbalances the centrifugal force will enter the fan intake and be delivered as the finished product. The other particles will be thrown out of the air current back to the mill.

We will now assume that for some reason or other the speed of fan is increased. This would tend to increase the carrying properties of the air and in some systems coarser particles would be lifted and delivered with the finished product, changing the uniformity of the product. In the Raymond system, however, just as soon as the increase in air velocity takes place, lifting up more and more coarse, there is a corresponding increase in the centrifugal force acting on the particles, since centrifugal force increases with an increase of velocity, throwing the particles back again. We thus see that an increase in air velocity tending to change the uniformity of finished product is counterbalanced by the increased centrifugal force, and the equilibrium of the operation is maintained. Or, vice versa, a decrease in air velocity decreases the carrying power of the air, tending to increase the fineness, but a decrease in air velocity decreases the centrifugal forces acting on the particles, and the equilibrium is again maintained.

We can now readily see how important it is to use a high air velocity in order to be able to produce an appreciable centrifugal force acting on the product, which gives a fine product and at the same time maintains its uniformity. When we also consider the small size of the particles dealt with the importance of high velocity becomes more apparent. This velocity must be of such intensity and under such control that its centrifugal action on the particles can be so regulated as to separate particles whose difference in weight is less than one-thousandth of a milligram.

#### APPLICATIONS OF AIR SEPARATION.

In the industrial field air separation has replaced all other methods where an extremely fine product is required, for it gives a much larger capacity than is possible by screening or bolting. In fact, the fineness of the finished product attainable by air separation is practically unlimited. A finer product can be obtained than from the finest silk bolting cloth, and at a fraction of the cost.

The fineness of some materials that are being commercially separated to-day is greater than can be indicated by the finest testing sieves it is possible to make. When one realizes that there are screens on the market of 350 meshes to the linear inch, or 122,500 holes per square inch, some inkling is had of the fineness that can be attained in an air-separated product. The fineness of such materials can only be determined by a microscope and the mesh of the particles estimated.

Sticky materials, or materials that become sticky when handled, can be readily obtained by air separation; such materials are resin, pitch, shellac, and various gums used in making varnishes.

#### REMOVING IMPURITIES.

The excess air, which leaks in through small openings in the housing, is allowed to escape through the small pipe at the top of the bend of the return air pipe. This exhaust air contains exceedingly fine particles of ground material, too small to settle out in the cyclone dust collector. If the release of this material in the open air is objectionable or if a market for it is available, as is usual in the talc industry, it may be collected and saved. This is accomplished by passing the surplus air into the top of a tubular dust collector (Pl. VIII, *C*, p. 45), which consists of a large number of cloth tubes suspended from a header and terminating in a conical hopper. The meshes of the cloth are fine enough to hold back the small, solid particles, but allow the air to escape. The capacity of the collector may be increased or decreased by varying the lengths of the tubes.

This system of air separation is often applied to a pulverizer by attaching a double-cone separator to the discharge of the mill. A separate air-separation unit consisting of a feeder, a double-cone separator, and a cyclone collector, with or without a tubular dust collector is also available for the sizing of harder materials ground in the tube mills or other grinding machines.

#### EMERICK AIR SEPARATOR.

The Emerick air-separation system (Fig. 3) is an independent unit designed for the sizing of all finely ground materials, whether ground in tube mills, pulverizers, or other fine grinders. The principle of this machine has been well described as follows:<sup>14</sup>

#### CONSTRUCTION AND PRINCIPLE.

Construction of the machine is very simple. It consists of an outer casing, an inner separating chamber, a hollow shaft, to which is attached a fan carrying a distributing plate at the lower end, a stationary feed pipe extending down inside the hollow shaft, a damper to regulate the amount of air circulating through the inner chamber, together with a pair of gears, shaft, pulley, and

<sup>14</sup> Cement Mill and Quarry, Nov. 20, 1920, pp. 39-40.

bearings. Two openings in the bottom provide for the discharge of the fine material and tailings. The four bearings are of high-grade Babbitt; the thrust bearing supporting the hollow shaft consists of one bronze and two steel washers. Manholes are provided in the cover. Steel angle bars are attached

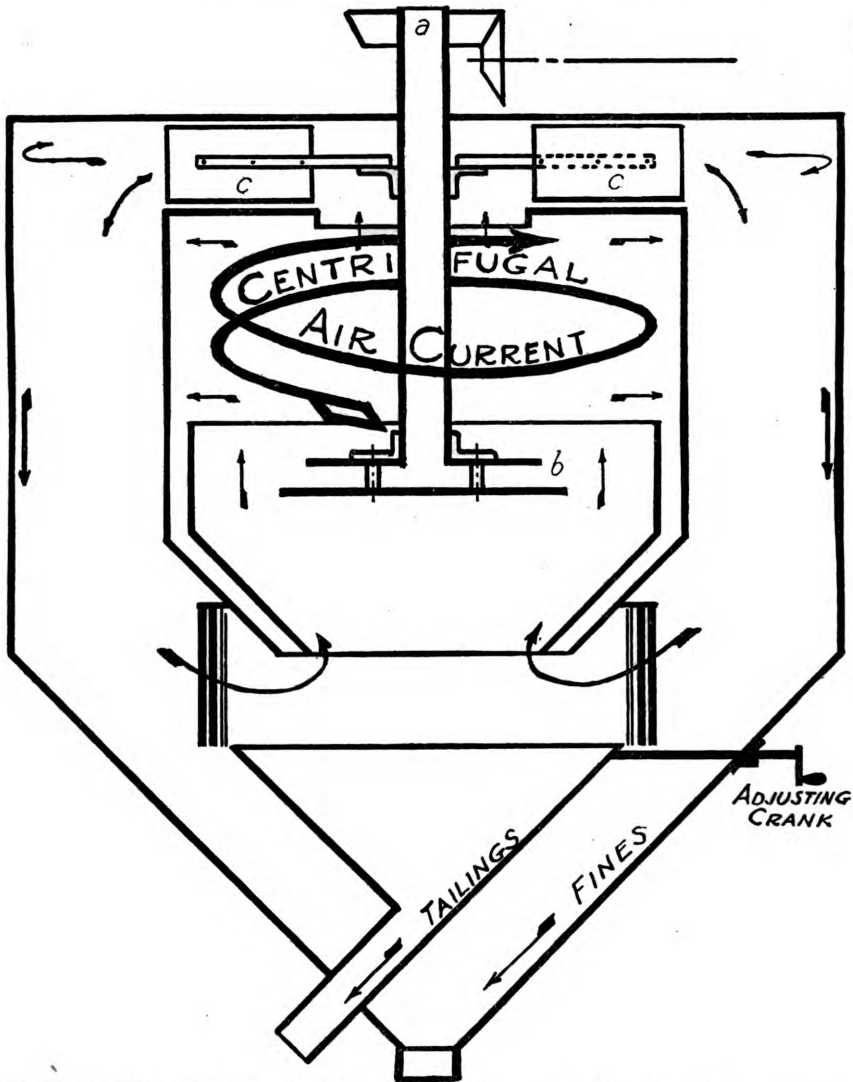

FIGURE 3.—Sectional view of Emerick air separator, showing direction of air currents. For explanation, see text.

to the top in pairs and project about 9 inches for supporting the separator on beams or posts, or it may be suspended from above, if desired.

The hollow shaft carrying the distributing fan is caused to rotate at a relatively slow speed at an average of 175 revolutions per minute. Material is fed into the stationary feed pipe *a*, as shown in the illustration (Fig. 3), and falling on the revolving distributing plate *b*, is thrown off in a thin sheet by

centrifugal force. The revolving fan *c* draws a current of air through this thin layer of material, fine enough to be lifted by the air current into the fan chamber. The fine material is discharged by the fan against the inner wall of the outer casing, sliding down the same to the outlet at the bottom. The air circulates downward between the inner casing through the opening between the inner casing and the lower cone, again passing through the material as it falls off the lower edge of the inner casing in the form of a circular curtain, removing any fine particles which were not taken out when the material was first spread by the distributing plate. The volume of air in circulation is controlled by an adjustable damper or valve, which regulates the fineness of the product. The area of the openings, direction of the air currents, and the deflecting arrangement of the parts are such that the fine material is removed from the air and settles to the bottom of the outer casing and is discharged through the outlet provided, while the coarse material falls into the lower inner cone and passes out through the tailings spout.

#### ADAPTABILITY.

The usual range of fineness required is from 60 to 300 mesh and the machine, when run at the speed recommended, can usually be regulated to give the product desired by adjusting the damper only. However, by varying the fan speed a large range of adjustment is possible. The separator can be supplied in extra heights for extremely fine or special material, and will give as fine as 98 per cent of 300 mesh.

It is probable that the use of systems of air separation will continue to increase, because of their many advantages over sizing by bolting reels and because of the growing demand for material finer than 250 mesh, which can be separated only by air separation or water classification.

#### WET GRINDING.

Wet grinding of talc has not been used commercially, at least in the United States, although some experimental work on it has been and is being done. The advantages that might be gained by the use of a wet-grinding method are as follows: The production of a finer-grained product with less consumption of power; the ability to use water classification for sizing and removing impurities; an opportunity to remove iron stains by bleaching or to improve the color by adding blue dyes. Some of the difficulties in wet grinding are iron staining from contact with iron grinding surfaces, cost and difficulty of drying product, and the necessity of pulverizing and sizing the dried product before shipping. These difficulties could be obviated or lessened so that it seems not improbable that wet-grinding methods will be developed in the future, especially where material finer than 300-mesh is desired in quantity. Iron staining may be minimized by grinding in porcelain or silex lined pebble mills or by acid bleaching. The problem of drying and disintegrating finely ground material is common in the clay, ocher, barytes, and other industries, and progress is being made in improving dry-

102740°—23—5

ing methods. A form of dryer now in use in some industries, which might be adapted to the drying of talc, is the spray dryer; in it a liquid suspension of the material to be dried is sprayed into a large heated chamber. The moisture evaporates immediately, and the dried material falls to the bottom of the chamber as an impalpable powder, which is removed by air currents to a dust collector. This system does away with the expense and inconvenience of repulverizing a dried cake and resizing by air separation.

Wet grinding has the further advantage of permitting water classification, or even an adaptation of flotation methods for very fine sizing and for the removal of impurities such as siliceous grit or grains of magnetite or pyrite. Such purification may become very important in the preparation of a high-grade product from some talcs such as are found in North Carolina and Georgia.

Recently a process of wet grinding and separation has been developed that promises success. It has been worked out by the Dorr Co. and uses a modification of the Dorr classifying and dewatering machinery common in the treatment of metallic ores. Test runs have been so successful that a southern talc company is planning to use this system in its new mill. The attached flow sheet (Fig. 4) indicates the proposed methods.

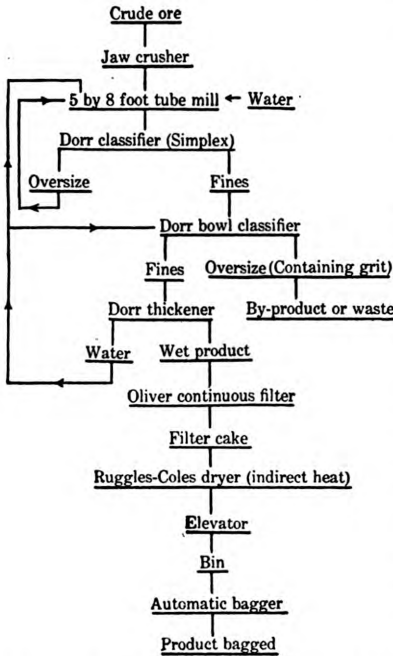

FIGURE 4.—Flow sheet of proposed talc mill using wet grinding.

a very fine uniform product but will practically eliminate siliceous grit, even when it is present in rather large quantities. If this elimination of grit holds true on a commercial scale, the system will mark an important step in the progress of talc milling. The most expensive stage in the method outlined is that of drying the product from the continuous filter; but this is offset by the fact that no drying of crude ore is necessary and the cost of wet grinding and water separation is lower than that of dry grinding. It is claimed that the total cost per ton of finished product is no higher by this method than by methods now in use, and that a finer, cleaner product is made.

Experimental tests have shown that this system not only yields

## BAGGING.

Nearly all finely ground talc is prepared for shipment by packing in either cloth or paper bags. This may be done by hand, by semi-automatic machines, or by entirely automatic machines.

## BAGGING BY HAND.

In bagging by hand the talc is allowed to run from the bin through a spout into the bag until it is nearly full. Then the spout is closed and the bag transferred to a platform scale, where the exact weight is made up by additions from a hand scoop. The bag is sewed or tied with wire or cord.

## TALC PACKERS.

The talc packer most commonly used in the talc industry is the semiautomatic type as illustrated in Plate XI (p. 52).

The empty bag is fitted over the feed tube with its bottom resting on the movable platform. By closing a friction clutch, talc is fed into the bag by means of an auger, the platform gradually lowering until the bag is filled to the proper point, when an automatic trip stops the feeding. The bag is then removed, weighed—slight discrepancies in weight being adjusted from a hand scoop—and sealed by hand.

An entirely automatic packer that may be adapted to packing talc in bags is the Bates valve bagging machine (Pl. XII, p. 53), which is designed primarily to fill a type of paper bag having a specially designed top with an envelopelike opening and filled through a long filling tube. The machine automatically fills and weighs the bags, and when the desired amount of material is in the bag the feeding automatically stops. Upon the removal of the filled bag the pressure of the material inside closes and seals the opening.

## FACTORS IN THE USE OF BAGGING MACHINES.

The use of automatic or semiautomatic bagging machines reduces the labor necessary in the packing room and increases efficiency. If baggers are used, enough storage capacity to hold at least a half-day's run of ground talc should be provided. If a mill is run on a 24-hour basis, it is often possible to store enough talc so that all of the packing can be done in one shift a day by the use of automatic packers. Some producers object to the use of automatic packers on the ground that storage capacity is necessary to run a bagger continuously and that storage of ground talc is not efficient; these users declare (1) that the mill product can not be changed from one grade



to another without emptying the storage bins, although this objection could be removed by the use of a reserve bin kept empty for this purpose; (2) that if impurities or off-grade stock should go through the mill by accident, a whole bin of talc would be ruined or lowered in grade; (3) that a closer check can be kept on the product and necessary changes made sooner if no bins are used. The last two arguments really amount to the same thing, and can be met by taking and testing samples at frequent and regular intervals from the chute that discharges into the storage bin. Irregularities can be detected in this way and checked before appreciable damage is done. Such frequent testing is desirable whether or not bins are used.

The use of storage bins for finished talc is considered desirable for the following reasons: (1) Machines can be used by which talc is weighed into burlap or paper bags rapidly and accurately and with much less labor than by hand; (2) the product of a grinding plant running three shifts can be stored and all bagged by machine in one shift; (3) breakdowns in either the grinding or the bagging department will not cause delays in the department unaffected; (4) talc can be bagged either by hand or by machine, whereas without storage capacity the machines would be used inefficiently if at all.

The most common sizes of bags used in packing talc are 50-pound paper; 50 and 100 pound cloth; and 150, 175, and 200 pound burlap. If much finished talc, packed in bags, is to be stored or rehandled several times before shipment, it is advisable to pack in cloth or burlap bags, as much talc may be lost by breakage of paper bags. Another factor influencing the choice of the container is the manner in which the talc will be used. It is a common practice in some paper mills to put talc into the paper-pulp mixture without removing it from the bag. Of course, for such use the bags should be of paper without metal fasteners or wires for sealing.

#### STORAGE.

Adequate storage capacity for crude ore, intermediate products, and finished talc packed in bags should be provided, though most mills are deficient in some one of these requirements. Storage capacity should be provided at several intermediate stages in the milling process, particularly if the mill is designed for a large capacity, otherwise breakdowns or delays at any machine make necessary a shutdown of the entire mill. Production loss is one of the chief causes for high costs.

The milling process may be divided into several units or stages, each with its separate power drive, so that any one unit may be stopped independently. For each unit enough bin capacity can be provided to hold several hours' production. The size and capacity

of the mill, the method of milling, and the space available govern the number and size of bins.

Capacity for storing a large quantity of finished talc before bagging has been considered by one company that objects to the storage of talc already packed because of the rehandling necessary and the losses incidental to storage in paper bags. Accordingly they have prepared plans for the erection of a large concrete bin to hold several thousand tons of powdered talc. By a system of conveyors the talc would be distributed over the bin as it is made, and drawn off into a small packing bin from which it would be packed, as required, by automatic packers. Little or no bagged talc would be stored, and the bags would be loaded directly into cars for shipment. Of course, the automatic talc packers would have a capacity considerably greater than the regular mill capacity, to care for a congestion of orders. Instead of one large bin it would probably be better to provide a number of smaller bins to allow for the storage of several grades and to lessen the chances of spoiling large quantities of talc by faulty milling.

This plan has many evident advantages, but a critic claims that the talc would clog and stick so badly in the bins that it could not be drawn off. This argument may hold for some talcs and would be serious if no remedy could be found; but some method of agitation or stirring, either with compressed air or a mechanical stirrer, could probably be developed. An alternative method might involve the use of an air current in pipes instead of belt conveyors to convey the talc to the bins and from the bins to the packers. By this method sticking would probably not give serious trouble. For New York fibrous talc, however, the argument has recently been disproved, as a storage bin of moderate size for finished talc is now being used successfully without sticking and without the use of stirring devices. The new mill of the American Mineral Co., at Johnson, Vt., also uses large storage bins for finished talc.

The customary method of storing the finished product is in bags. Most talc mills have some warehouse space for such storage, although many mills do not have enough. If talc is to be stored instead of loaded directly into cars for shipment, the bags are usually piled by hand on trucks, carried into the warehouse, unloaded, and piled by hand into stacks. If the stacks are high, the bags may be rehandled several times before they reach the top. When the talc is removed for shipment, the bags must again be rehandled several times. This rehandling not only requires additional labor but causes losses when the talc is packed in paper, as previously noted.

In order to reduce labor in storing and removing bags from high stacks one company has used a portable electric elevator, known as

the "Revolvator." By this machine several hundred pounds may be raised vertically from the floor to a considerable height, which greatly facilitates stacking in high piles. This device eliminates some labor, but it is not entirely satisfactory. A great improvement could perhaps be effected by the use of a belt conveyor pivoted on a carriage or truck, which carries the motor for driving, in such a way that it may be tilted through a wide angle. Additional portable conveyor sections are obtainable, so that material in bags or other packers can be transported mechanically to any part of a warehouse and stacked to any height. By reversing the conveyors, material may be taken from storage and transported directly into freight cars for shipment. If labor is scarce or expensive, or if it is necessary to store much talc in paper bags, the installation of this system may be worthy of consideration.

#### SHIPMENT.

Most mills are on a railroad siding, so that cars may be loaded directly from the mill or warehouse, but at some plants the finished talc has to be transported to a siding. One fairly large mill, not on a railroad, uses a  $3\frac{1}{2}$ -ton motor truck to haul finished talc about  $1\frac{1}{2}$  miles to a railroad. Truck haulage answers well enough where haulage is absolutely necessary, but the mill should be, if possible, on a siding. If the choice is between hauling crude talc to the mill or of hauling the finished product to a railroad, the former is always preferable. Crude talc can be transported with no hand labor, but talc in bags must be rehandled several times by hand, with increased costs and losses by breakage of paper bags.

Practically all bagged talc is shipped in box cars. When the empty cars arrive for loading they are often dusty and dirty from having been loaded with coal, ore, or other material in bulk. For this reason many cars have to be cleaned by brushing or even by washing. In addition many cars are completely lined with cheap building paper. If talc is shipped in paper bags and is to be used without dumping in the manufacture of paper, it is highly important that the car be lined or at least very carefully cleaned. A paper manufacturer once complained that a carload of talc was badly off-color and that a large quantity of paper had been spoiled. Investigation showed that the talc had been shipped in a dirty car and had been dumped, still in paper bags, into the pulp mixture. The talc producer and the paper company were both at fault, one for improper loading and the other for lack of inspection.

**ACCESSORY MACHINERY.****ELEVATORS AND CONVEYORS.**

In every talc mill more or less accessory machinery, such as elevators and conveyors, must be used. Such equipment is so well standardized that little comment is necessary, but a few fundamental facts may be emphasized. The power consumption of elevators and conveyors is usually comparatively low, yet their repair cost may be high and delays from breakdowns may be very expensive. For this reason it is well to design a mill so that transportation by elevators and conveyors is reduced to a minimum. The use of a hillside for a mill is of great advantage in this respect. For the transportation of finely ground or even moderately coarse material, the use of compressed air has been suggested and has been adopted by some industries. This method probably could be applied with success to the conveying of ground talc.

**ORE FEEDERS.**

The use of ore feeders to provide a steady and well-regulated feed to crushers and grinders is becoming general. Mechanical feeding devices increase the efficiency of grinding machinery so greatly that their cost is more than repaid. Some grinding machines, such as the Raymond roller mill, are equipped with feeders by the machinery manufacturers, but if feeders are not provided, their installation should be carefully considered.

**MAGNETIC PULLEYS.**

In all mining and milling operations a certain amount of tramp iron, such as nails, hammer heads, and drill bits, inevitably becomes mixed with the ore. If this iron is allowed to go through the crushing and grinding machines it not only may damage them but it also contaminates the finished product. It may be effectively removed by a magnetic pulley on the head end of a belt conveyor preceding the primary crusher. If the crusher is fed from a chute by gravity it is usually a comparatively simple matter to put in a short belt conveyor. Some of the largest and most efficient talc companies are now using magnetic pulleys.

**POWER PLANT.**

At the various talc mills visited the consumption of power varied from 61 to 375 horsepower per ton of hourly capacity. The cost of

power may therefore be a decidedly important item in the total milling cost, and the most efficient and economical source of power should be chosen. The author noted mills using hydroelectric power, steam, water, and steam-generated electric power and gasoline engines.

Where plenty of cheap water power is available, this source is usually the cheapest. But where water power is unavailable, the choice of the best and cheapest source of power may involve considerable study. In some localities the difficulties of obtaining power are so great that mills are built in a large centrally located city and the ore is brought in by rail. Electricity is an efficient form of power; and where it can be purchased at reasonable rates from a dependable source, it is probably most desirable. Individual motor drives may be arranged for each machine, or the mill may be divided into sections, each with its own motor, so that any machine or section of machines may be started or stopped independently. Individual motor drives also permit the use of individual voltmeters, ammeters, and wattmeters for noting the performance of each machine and for keeping accurate costs of each stage of the milling operation. Where the cost of power is high, each machine should run at highest efficiency; this can be done most easily with electric power.

If electric current is not purchasable, it is usually not advisable to attempt to generate electricity by steam power, as small steam-power generating plants can not usually be run efficiently. The use of direct-connected steam power is more advisable. It is almost always cheaper to buy electric power than to generate it by steam, but under some conditions small hydroelectric plants may be used advantageously.

#### MANUFACTURE OF PENCILS AND CRAYONS.

Talc suitable for sawing into crayons and pencils is found mainly in North Carolina and Georgia, but some pencil stock is produced in Vermont, Maryland, Virginia, and California. By far the largest output of talc crayons formerly came from North Carolina and Georgia; but now one mine in Vermont is an important producer.

Pencil stock must be free from cracks and joint planes and so firm that it may readily be sawed into thin strips strong enough to stand rather hard usage. A very soft pencil is not desirable, as it breaks easily, wears down rapidly, and tends to burr over on the end. On the other hand, if a pencil is too hard it will not mark on a soft material and the point glazes over. The presence of grains of pyrite or magnetite makes a massive talc difficult to saw and dulls the saws very rapidly. Finished crayons from such stock have hard spots and tend to scratch some surfaces.

The normal market for all grades of talc crayons is approximately 225,000 gross a year. The most common size of pencil is  $\frac{3}{16}$  by  $\frac{1}{2}$  by 5 inches and weighs from  $7\frac{1}{2}$  to  $8\frac{1}{2}$  pounds per gross. The entire crayon production of the United States therefore does not account for much more than 1,000 tons of talc in finished form. As the blocks suitable for sawing constitute but a small part of even the best deposits of pencil stock, the tonnage mined for this purpose is much larger. Sometimes the unsuitable material is ground, but in mines remote from transportation facilities it is often wasted. Pencil-sawing equipment is rather inexpensive, so that many small mills have been built. The crayon-mill capacity of the South alone is probably double the normal consumption.

The equipment of pencil plants differs but slightly in various mills, except for the size and number of saws. One mill has one 24-inch facing saw, one 16-inch cut-off saw, one 16-inch stocking saw, and four 8-inch pencil saws. Another mill has one 20-inch cut-off saw, one 10-inch blanking saw, and three 8-inch pencil saws. Ordinary circular saws are used, such as those in woodworking plants, the blocks of talc being pushed through by hand.

For a completed description of a typical pencil mill, see page 97.

Efforts have been made frequently to produce a satisfactory pencil from ground talc plus a liquid binder such as sodium silicate. One company now produces pencils made in this way, but the total output has not yet become significant.

#### USES OF TALC AND SOAPSTONE.

The uses of talc are many but are not in general well known or fully developed. Several companies have realized the possibilities of greatly increased use and have proceeded intelligently to develop some of the most promising fields, thereby lifting talc from its obscurity. The work, however, is only started, and much remains to be done. More attention has been paid to the technology and utilization of talc in Germany and Austria than in the United States, despite the fact that the United States produces 65 per cent of the world's talc and Germany and Austria together only 5.4 per cent. In the "Bericht über die Tätigkeit des Verbands der Talcum-Interessenten in Oesterreich-Ungarn" (Proceedings of the Austria-Hungarian Talc Association), for the years 1912 and 1913, many notes concerning new uses appeared with suggestions on further development of old uses. Aside from a few notes regarding the use of talc in paper little information on this subject has been published in the English language.

## LIST OF USES.

An outline of the various uses of talc and soapstone is given below:

## Uses of powdered talc and soapstone.

## 1. Paper manufacture:

- a.* Filling or loading of all grades of paper.
- b.* Ingredient of coating mixture on glazed or finished papers.
- c.* In tissue-paper manufacture from sulphite stock.
- d.* In the manufacture of blotting and absorbing papers.
- e.* For the bleaching of cellulose.
- f.* For removal of resin from cellulose.

Quality: 200-mesh or finer. Colloidal property demanded. Presence of lime sometimes objectionable.

Color: Colorless; free from ferric salts, for white paper. Color not important for wrapping paper.

## 2. Roofing-paper manufacture:

- a.* Filling or loading.
- b.* Coating, to prevent sticking together.
- c.* Surfacing.

Quality: For filling and coating, 200-mesh. For surfacing, 40 to 80 mesh.

Color: Negligible.

## 3. Textile manufacture:

- a.* Dressing cloth.
- b.* Coating, sizing, and bleaching cotton cloth.
- c.* Dyeing.
- d.* Dry polishing or sizing of pile fabrics.

Quality: 200-mesh.

Color: Dependent on use.

## 4. Rubber manufacture:

- a.* Filling.
- b.* Dusting.
- c.* Packing material for rubber.
- d.* Protective coating for crude rubber.
- e.* On molding tables in making tires.
- f.* In manufacture of rubber tubing for bedding tubing during vulcanization.

Quality: 200-mesh.

Color: Negligible.

## 5. Paint manufacture:

- a.* Pigments; absorption of complex coloring matters.
- b.* Filler or extender, particularly in mixed paints.
- c.* Cold-water paints.
- d.* Enamel paints.
- e.* Waterproof paints for protection of metal, stone, and wood.
- f.* Flexible roofing paints and cements.
- g.* Fireproof or fire-resistant paints.
- h.* Base for disinfectant paints.

Quality: 200-mesh or finer. Colloidal property demanded in most paints.

Color: Dependent on use.

## 6. Soap manufacture:

a. Filler.

b. Constituent of soap compound.

Quality: 200-mesh only, colloidal property demanded in (b).

Color: Dependent on use.

## 7. Foundry-facing manufacture:

a. Replacing graphite.

b. Mixed with graphite.

Quality: 200-mesh.

Color: Dependent on use.

## 8. Toilet preparations:

a. Face powders.

b. Toilet powders.

c. Foot powders.

d. Creams, pastes, and lotions.

Quality: 200-mesh or finer; freedom from grit, iron, and lime; good slip.

Colloidal property advantageous when used with liquids.

Color: White or flesh color.

## 9. Wire-insulating compounds:

Quality: 200-mesh.

Color: Dependent on use.

## 10. Lubricants, liquid or grease:

a. Talc alone.

b. Incorporated with heavy oils, 40 to 60 per cent talc.

c. With water, talc in colloidal state.

Quality: 200-mesh.

Color: Negligible.

## 11. Linoleum and oilcloth manufacture:

a. Filling.

b. Dusting.

Quality: 200-mesh.

Color: Dependent on use.

## 12. Pipe-covering compounds.

## 13. Pottery and porcelain:

a. Body material for china, porcelain, and porcelain crucibles.

b. Glaze.

## 14. Electrical insulation:

a. Artificial or synthetic lava—talc with binder.

b. Substitute for electrical porcelain—talc with clay, with or without liquid binder.

Quality: 200-mesh.

Color: Dependent on use.

## 15. Rope and twine manufacture:

a. Filling.

b. Finishing.

Quality: 200-mesh.

Color: Dependent on use.

## 16. Leather manufacture:

a. Dressing skins and leathers.

b. Drying oily leathers.

c. Substitute for wheat flour in making glacé kid.



17. Cork manufacture:  
*a.* Dusting molds.  
 Quality: 200-mesh.  
 Color: Negligible.
18. Oil manufacture:  
*a.* Filtering medium.  
 Quality: 200-mesh.  
 Color: Negligible.
19. Glass industry:  
*a.* Polishing powder for glass, especially plate glass.  
*b.* Dimming and clouding glass.  
*c.* Dusting glass, bottle molds.  
 Quality: 200-mesh.  
 Color: Negligible.
20. Portlant cement and concrete:  
*a.* Ingredient of special cements.  
*b.* Part of concrete aggregate.  
*c.* Surfacing material.
21. Wall plaster:  
*a.* Ingredient.  
*b.* Finishing.
22. Asbestos industry:  
 Ingredient of asbestos shingles, blocks, and slabs.
23. Manufacture of crayons, plaques, and blocks.
24. Preservative coating on stonework.
25. Cleaning and polishing rice, peas, coffee, beans, maize, barley, peanuts, and similar food stuffs:  
 Quality: 200-mesh.  
 Color: Negligible; colored talcs are used for colored products.
26. Bleaching barley grain of inferior color. Used with sulphur-dioxide gas.  
 Quality: 200-mesh.  
 Color: Negligible.
27. Dusting in rubber-stamp manufacture:  
 Quality: 200-mesh.  
 Color: Negligible.
28. Composition floor manufactures.
29. Insulating material for switchboards and floors of generating stations.
30. Imitation stone:  
*a.* Marble and jointless flooring.  
*b.* Sanitary appliances.
31. Boot and shoe powder:  
 Quality: 200-mesh.
32. Glove powder:  
 Quality: 200-mesh.  
 Color: White.
33. Dermatology:  
*a.* Absorbing colors, colloidal solutions, fats, and oils.  
*b.* Absorbing odors.
34. Absorbing colors of animal, plant, and artificial origin.
35. Veterinary surgery:  
 For dusting wounds and sores, and for treating skin diseases of cattle and other animals.

36. Purifying, decolorizing, and degreasing of waste waters:
  - Quality: 200-mesh, colloidal properties demanded.
  - Color: Negligible.
37. Manufacture of water filters, similar to Berkfeld.
38. Conserving fruits, vegetables, and eggs.
39. Sugar refining.
40. Contact material for catalytic reactions.
41. Absorbent for nitroglycerin.
42. Packing material for metallic sodium and potassium:
  - Used wetted with oil.
43. Fireproofing wood:
  - \*Used with sodium silicate (water glass).
44. Acid-proof and fireproof packing and cement, for pipe, and such articles.
45. Automobile polish.
46. Filler in manufacture of fertilizers.
47. Agriculture:
  - a. Filler or extender for insecticides.
  - b. Ingredient of remedies for plant diseases, such as "Fostit" or mixture of copper sulphate with ground talc or soapstone.
48. Shoe polish and cleaner:
  - a. Cleaner for white-canvas and buckskin shoes.
  - b. Ingredient of polish for leather shoes.
49. Yarn and thread manufacture:
  - a. Dressing.
  - b. Polish.
50. Chemical-pharmaceutical industry:
  - a. Powder.
  - b. Tablets.
51. Colored crayons:
  - a. Crayons of chrome colors, and pastel colors.
52. Stove polishes.
53. Imitation amber.
  - For clouding effects.
54. Cleaning and glossing of hair and bristles.
55. Floor wax.
56. Terrazzo or mosaic flooring.
  - In place of oil in laying terrazzo.
57. Candy manufacture.
  - With starch, or other medium as dusting agent to prevent sticking in molds, on molding boards, etc.
58. Window shade manufacture; to render cloth opaque.
59. Chewing-gum manufacture; as dusting agent to prevent sticking.
60. In manufacture of putty, as filler.

#### Uses of massive talc and soapstone.

1. Lava blanks for electrical insulation, gas burner tips, and sparks plugs.
  - Quality: Massive, fine-grained talc, free from iron and grit, no cracks or cleavage planes. Must be soft and easily machineable but compact and strong. Must be tested under heat.
  - Color: Negligible in raw state, but white color preferable after burning.

2. Crayons and pencils.  
Quality: Compact, massive talc, medium hard, strong when sawed into thin, narrow strips.  
Color: Negligible.
3. Tailors chalk or French chalk.  
Quality: Compact and strong, fine grained, but medium soft.  
Color: White or light color.
4. Glass making.  
Molds for bottles, watch glasses, etc.
5. Metallurgical industries.  
Molds for casting of iron, brass, copper, etc.
6. Refractories.  
Fire brick and blocks.
7. Polishing agent.
  - a. Wooden handles, etc. Small blocks of talc tumbled in cylinder with wooden handles to fill grain of wood and give rough polish.
  - b. Polishing and lubricating wire nails used in automatic box-nailing machines. Blocks of talc tumbled with nails.
8. Carvings.  
Chinese and other Oriental carvings.
9. Cooking utensils.  
Used by uncivilized peoples in various parts of the world.
10. Soapstone slabs.
  - a. Electrical switchboards and base plates.
  - b. Acid-proof laboratory tables, sinks, hoods, and tanks.
  - c. Laundry tubs and sinks.
  - d. Fireless-cooker stones.
  - e. Foot warmers.
  - f. Griddles.

#### FACTORS CONTROLLING USE.

Talcs, in common with other nonmetallic minerals, do not have definite and constant physical and chemical properties; results obtained in the study of one talc will not necessarily hold true for all talcs. Just as each clay used in pottery must be tested for its own peculiar properties, so must talcs be tested, for some uses. Clays differ in color, grain, size, plasticity, bonding strength, melting point, and vitrification range. Talcs probably do not vary as widely as clays, but nevertheless, a variety of talcs should be studied for each use. Thus, in testing talc for use in porcelain bodies, one ceramist might find the fusion point of talc low and the range of vitrification very short; another might find a high fusion point, with a long vitrification range, and a slow uniform fusing. Both might be right, for the particular sample used; but neither result could be said to be true of all talcs. Furthermore, some materials sold and used as talc are not talc at all, strictly speaking, but pyrophyllite, or a hydrous aluminum silicate instead of a hydrous magnesium silicate. Representative samples of a wide variety of talcs should consequently be tested uniformly in all research work.

Some of the properties of ground talc which should be determined are as follows:

(1) *Physical properties*.—Grain size, shape of grains, color, impurities, melting point, vitrification range, absorption, bonding strength, "slip," colloidal properties.

(2) *Chemical properties*.—Presence of lime, iron, and other impurities, amount of uncombined water.

#### UTILIZATION OF TALC.

##### PAPER MAKING.

Probably the largest single use of talc is as a filler or loading material in paper. The manufacture of newsprint consumes the largest quantities, but talc is used also successfully in many papers, from the cheapest to the finest grades. For the manufacture of the best grades of paper the requirements are freedom from grit (both oversize and siliceous impurities), alkalies, and carbonates; a fine-grain size (200-mesh or finer), and a pure-white color. For use in paper, talc must be procurable at a price about equal to that of the best white clay; but paper makers could afford to pay slightly more if the talc is retained in paper better than the clay.

The matter of retention is very important as only the proportion of talc that is actually retained is useful. From many tests by chemists of paper mills on different talcs it seems definitely proved that talcs show a greater retention than most clays—in some talcs very much greater. In this respect true talc and pyrophyllite are alike. Results obtained by the laboratory of a large paper mill in an interesting series of retention tests of a pyrophyllite talc from Glendon, N. C., and of a typical high-grade clay are given below:

TABLE 4.—Retention tests of talc and clay.

Proportion added (per cent).	Retention (per cent).	
	Talc.	Clay.
10	85.8	58.5
15	85.8	59.0
20	73.7	67.2
25	71.7	66.0

In examining talc for use as a paper filler, the methods and tests used for clay fillers are not applicable. Many paper men do not realize this fact, and therefore have often condemned talc as unsuitable for this reason. The retention of clay in paper is usually a function of its plasticity or ability to stay in suspension in water. If a clay shows poor suspension, the more difficult retention tests are often

not made, and the filler is declared unsuitable. This test is usually fair for clays, but the suspension of talc is often very poor, whereas the retention is very high. Talc producers who wish to sell their product as a paper filler should be sure that actual retention tests are made (if the talc is otherwise suitable) instead of suspension tests.

The following data<sup>15</sup> indicate the wide range of uses for talc in the paper industry.

#### TYPES OF PAPER.

Sugar papers treated with talc give from 60 to 80 per cent ash, so that talc is preferable to kaolin. Talc also covers better and is more economical than blanc fixe.

*Mill-finished papers.*—Provided the raw material has been well prepared and sufficiently sized, talc has always given good results on mill-finished papers.

*Colored papers.*—The shade of colored papers prepared with talc is more pronounced and the glazing better than those treated with other minerals.

*Wall papers.*—Talc entirely prevents transparency when a new wall paper is placed over an old one.

*Heliographic papers.*—Talc is not only employed as an addition in the pulp, but also to give photographic papers a special surface.

*Paper for poly copies.*—Talc is very useful as a raw material. So far it has not been tried for recopying papers, but it facilitates the binding of duplex papers.

*Hectographic papers.*—The employment of talc is very advantageous in these qualities.

*Impregnated papers.*—As talc resists the effect of air and moisture, it can be advantageously employed for papers used for preserving purposes. Talc added to salicylic acid is a good preservative. It is also useful in the production of waterproof pasteboards.

*Grease-proof papers.*—In certain mills talc is used in the production of these papers. The quantity of the loading depends on the thickness and the purpose for which the paper is to be employed.

*Crêpe papers.*—The addition of a little talc to crêpe papers imparts a suppleness, but it must not be used for Chinese fiber papers.

*Tissue papers.*—Talc is an important factor in the preparation of silk papers made from wood pulp to replace the thin rag papers, as it is the only mineral that helps to produce the appearance of a rag paper. It diminishes the silky appearance and increases the opacity.

*Thick papers.*—For certain pasteboards and thick papers talc is useful, as it imparts moisture-resisting properties. This is particularly the case with highly glazed papers.

*Pasteboards.*—Talc gives the pasteboard a certain strength and prevents it from breaking when being cut. Talc is therefore a useful addition in the manufacture of playing cards. It can be used for most kinds of pasteboards. Added in proper quantities to the beaters, it imparts a special surface and advantageously influences the coloring. In certain cases talc can replace asbestos for packing steam joints. Mixed with sulphite, a pasteboard can be made which can be used for boiler joints. The pulp so prepared is practically indestructible, whereas pasteboard made without talc requires to be replaced at each boiling. Talc-prepared pasteboard has also been used to replace the rubber parts of a hydraulic press with most satisfactory results.

<sup>15</sup> Pulp and Paper Magazine (Canada), Jan. 1, 1915, pp. 19–20.

*Papier-mâché.*—Different trials made with talc have given good results in the making of papier-mâché. This especially applies to papers used for cartridge tubes and receptacles of all kinds.

#### INFLUENCE OF TALC.

*Finishing and coloring.*—Papers and pasteboards containing talc acquire a very high surface. Printing papers made from a mixture of 80 per cent fresh mechanical pulp and 20 per cent wood pulp can be sized with talc bound with about one-fourth per cent potato starch, after the pulp has been made mordant with sulphate of alumina. This treatment fulfills all conditions required for a good sizing of newspaper paper of average weight, while a great economy of rosin and alum is effected.

*Mineral loadings.*—For papers requiring a good sizing it is generally advisable to add talc after the sizing has taken place. Good writings have been obtained, however, by adding first in the beater the solution of sulphate of alumina, then the talc, and finally, just before emptying, the cold-sizing milk. The loading waste is generally less if the talc is added before the size.

*Whiteness.*—An addition of talc imparts to raw sulphite pulp or lightly bleached fibrous matter a whiteness equal to that of highly white pulps.

*Flatness.*—Talc gives a perfect flatness to paper which no other mineral enables it to obtain. It prevents the paper from shrinking after the damping and during the calendaring.

*Use of blocks.*—As already stated, talc is the best means of protection against the presence of dust in papers made from cylinder machines. It is only thus that lithographic papers can be produced which will not damage the surface of blocks.

*Talc as a substitute for rosin.*—It has been generally admitted that Americans were the only manufacturers able to produce news paper without rosin, as the pulp they employed contained natural colloidal rosin, so that the only addition they required was asbestos or talc. Papers free from mechanical pulp, not sized, have been very successfully produced in European mills, however, for the production of the most finished printings, and especially the famous Oxford paper.

The fundamental basis of this manufacture resides in the employment of minerals, of which talc is the chief, for the following reasons: The more the surface is able to absorb color, the less ink and coloring impregnants (such as turpentine) are required and less pressure is needed at the moment of receiving the color; talc is the finest distributor, adheres equally to the small fibers, and prevents irregularities of the surface of the paper. When the printing is done properly the finest lines appear neatly on the paper. In these conditions high-priced rosins can be totally or partly dispensed with, according to the nature of the pulp.

Talc prevents colors from appearing in transparency when printed on thin Oxford paper.

#### USE OF TALC IN SCANDINAVIA.

In an important Scandinavian mill, where Chinese and Japanese absorbent paper is made with Styrian talc, a test revealed that from 90 to 95 per cent of the talc remained in the paper. The results were obtained without the addition of potato starch.

The papers containing talc commanded a price almost equal to that of very high quality paper. They were suitable for pen and brush writing, and their whiteness and purity and entire absence of sand brought them into favor and

created a demand. They were also easily worked on the machine, and the sheet did not adhere to the presses as when potato starch was used. Moreover, the felts and wire did not get dirty so quickly as when potato starch was used, and the life of the felts and wires was longer and depreciation considerably lessened.

The greasiness of talc enables it to be absorbed at a higher grade than any other loadings, and it gives more resistance to the structure of the paper, of which it suppresses the roughness.

#### ADVANTAGES OF TALC.

Before the employment of chlorine for bleaching, the whiteness of the papers was augmented by the use of minerals that answered the purpose on account of their own whiteness and covering qualities. These mineral matters gave more brightness to the white-rag shade and thus increased its white appearance.

About the middle of the last century Belgian paper makers, and later on Germans, produced papers strongly loaded with mineral matters. These papers were soon greatly in demand. Later still the making of mechanical pulp supplied a cheap raw material; but the papers containing such pulp were not liked, and the prejudice was justified through the want of technical experience at the beginning.

Chemical pulp then made its appearance, and in this the defibered wood found a valuable auxiliary. The chemical and mechanical fibers were felted together in a very advantageous way on the machine, though a third substance was wanted to fill up the pores and empty spaces of the mechanical pulp, as this by itself has very little suppleness. Talc, together with the mineral loadings and rosin size, produces an even web. The paper loses its woody character and acquires the appearance and feel of rag paper.

The obstacles that the new method often met must be attributed to wrong treatment. In some cases the quantity of loading or mechanical pulp added to the rags or wood pulp was too heavy; in other instances the addition was too small or the material was unsatisfactory or the workmen were too inexperienced.

All minerals used as loadings before the employment of talc have shown their defects. Lime sulphates, though pure and white, remained in a small proportion only in the paper. The asbestine imported from America, which is a kind of siliceous magnesia, has given fairly good results, but its dryness and rough feel made it objectionable.

Talc, which is also a silicate of magnesia—but free of iron, sand, and chalk—answers all requirements as the smoothest loading material and the softest to the touch.

#### POTTERY.

One of the less known uses for talc is in the manufacture of pottery and porcelain. The properties and uses of talc have been studied more extensively in Austria and Germany than in the United States, and pottery containing talc has long been in use there. A large quantity of ware has been manufactured, known as "Steatit," composed of talc or steatite and clay.

In the United States the use of talc in the ceramic industry has been studied to some extent, and a paper entitled "Talc as a body material" was prepared in 1913 by Parmelee and Baldwin.<sup>16</sup> These inves-

<sup>16</sup> Parmelee, C. W., and Baldwin, C. H., Talc as a body material: *Trans. Am. Ceram. Soc.*, vol. 15, 1913, pp. 532-546.

tigators used a talc purchased from a dealer in potters' supplies and mixed it with five different bodies in proportions varying from 1 to 30 per cent. The results of their work they summarized as follows:

Talc as a body material may be introduced in considerable quantities, at the expense of the clay content without affecting the working properties of the body.

It has a decided influence toward promoting the translucency of the ware, even when introduced in small quantities. The light transmitted through such translucent ware is of a whiter quality.

The color of the ware is made whiter by the addition of the talc, and becomes of a grayish tone in some mixtures.

Talc promotes vitrification in the body; this vitrification proceeds slowly and apparently without the sudden fusion peculiar to lime.

Progressive additions of talc to a body up to certain limits increases the toughness as measured by abrasion loss. This increase is noticeable with all the feldspar contents examined. This is in accord with the statement by Richard<sup>17</sup> that "the usual lime earthenware is comparatively easily breakable. The introduction of magnesia as well as lime into the clay body gives more resistive power toward knocks or pressure."

Experiments have also been made with talc as a constituent of glazes for porcelain. Kanashima,<sup>18</sup> as a result of his work on a talc from Manchuria, China, reached the following conclusions:

1. Talc glaze is more fusible than lime glaze.
2. Talc glaze is not as liable to overfuse as lime glaze.
3. Talc glaze is generally more lustrous than lime glaze.
4. Development of color in underglaze is less brilliant with talc.

If these results can be substantiated by using domestic talcs, a new, though perhaps small, field of use should be developed.

The value of talc in the form of "lava" for both heat and electrical insulation has long been known, but synthetic or artificial lava, made from ground talc, has not been commonly used in place of electrical porcelain. Experience has shown that porcelain at temperatures above 300° C. is worthless for electrical insulation, and at 600° to 700° C. acts as a conductor rather than an insulator. In addition, porcelain will not stand rapid changes in temperature through large limits. But lava, or a mixture of talc and clay, may be heated to redness and plunged in cold water without injury. When talc is baked to form lava, the lava has practically no expansion or contraction, and standard threads cut in the original talc are still standard after baking into lava. The dielectric strength or insulating value of lava is as great as, or greater than, that of porcelain, even at high temperatures. In fact, Barringer states, in a discussion of the paper by Parmelee and Baldwin, previously mentioned, that a body containing "talc is enormously more heat resistant than porcelain and enormously better as an electrical insulator."

In consideration of these facts, further investigation of the ceramic uses of talc and practical application of the results, both in the manufacture of chinaware and in electrical insulation, would seem to be highly desirable.

Three factors governing the use of any material are adaptability, superiority over material already in use, and cost. For talc,

<sup>17</sup> Proc. Cong. Appl. Chem., 1909. Abstracts Eng. Cer. Soc., vol. 8, p. 13.

<sup>18</sup> Kanashima, S., Jour. Chem. Ind. Tokyo, vol. 20, 1917, pp. 850-860.



the first two factors have been proved, at least in part. The question of cost may be settled easily by comparison with other ceramic materials. In 1920, English china clay, powdered, sold for \$30 to \$60 per ton; domestic china clay, powdered, \$25 to \$40 per ton; feldspar, \$13.50 to \$18 per ton—all prices f. o. b. New York—but talc, powdered, could be obtained at \$12 to \$17 per ton. Talc of the very best grade, suitable for toilet use, sold for prices up to \$60 to \$70 per ton, but material of this grade need not be used in the ceramic industries. As talc would serve as a partial substitute for both china clay and feldspar, evidently there can be no argument against talc on the basis of price.

Ceramists, or companies considering the use of talc, should note the varieties of talc and the differences in methods of preparation. Unlike the metals, the nonmetallic minerals have varying physical and chemical properties. It is not possible to decide that talc in general is or is not suitable for a specific use until several different talcs have been tried. By direct contact with talc producers, it is often possible to obtain a variety of grades not possible in indirect purchases.

#### PAINTS.

Talc has been used for a number of years as a filler in the manufacture of mixed or ready-prepared paints. At first it was used secretly and was regarded as an adulterant; but gradually by actual tests and impartial research it was found that talc had valuable properties that really improved paints used for some purposes. To-day paint chemists regard talc as a paint material of great value.

Standard works on the chemistry and technology of paint materials and mixed paints present photomicrographs of various forms of ground talc offered for sale to the paint trade. Some of the essentials of a mineral filler for paints are fineness, good color, freedom from grit, and uniformity. All material should pass a 200-mesh screen and preferably a 300 or 350 mesh screen. In these photomicrographs it is clearly demonstrated that much of the talc formerly on the market was not uniform in size and some of it was coarser than 200 mesh or coarser than many other materials illustrated. Prejudice, based on this improper preparation and some undeserved criticism, has been difficult to overcome. To-day talcs in some localities are prepared very carefully, being uniform, fine in grain, and far superior to the former products. Air-floated talc, properly milled, should be, and is, a material admirably adapted for use as a filler or extender for some classes of paints.

To the paint trade talc has been known variously as asbestine (fibrous talc from New York), talcose, soapstone, and talc. These

differences in nomenclature have not helped the talc industry. Although talcs from different places differ both physically and chemically, they are all talc, and, if properly prepared, should be suitable for the same or similar uses.

When ground to 200-mesh or finer the shape of the grains becomes more similar and the difference between fibrous and foliated or massive talc becomes less important. Massive talc is said to be unsuitable for paint manufacture, but this claim is probably questionable. Theoretically, a talc that has a tendency to grind into small, flat grains or flakes is superior to one that produces fibers when used in a mixed paint, as a flake has a larger surface per unit of weight than a fiber and is thus more easily held in suspension, and the covering power of flakes per unit of weight is greater than that of fibers on account of the greater surface exposed.

Talcs from all producing districts should be carefully examined and tested by disinterested research laboratories in order to demonstrate their suitability for this use.

The properties of talc, as used in paint, have been described by Gardner as follows:<sup>19</sup>

This pigment comes in two forms: As asbestine and as talcose (talc, etc.). The former is very fibrous in nature and is a very stable pigment to use in the manufacture of paint on account of its inert nature and its tendency to hold up heavier pigments and prevent settling. It also has the property of strengthening a paint coat in which it is used. The talcose variety is very tabular in form. Both varieties are transparent in oil and very inert. They have a gravity of about 2.7 and grind in about 32 per cent of oil.

Gardner describes a series of tests in which 47 paint formulas were used on test panels. Examination of the panels after three years of exposure showed that among those paints giving good results were two containing 26 and 10 per cent of talc, respectively. The first paint was composed of 22 per cent of basic carbonate white lead, 50 per cent of zinc oxide, 2 per cent of calcium carbonate, and 26 per cent of talc; the second contains 27 per cent of zinc oxide, 60 per cent of basic sulphate of white lead, 3 per cent of calcium carbonate, and 10 per cent of talc. This series of tests proved conclusively that a combination paint, made from two or more pigments, with a moderate amount of an inert filler, such as talc, was superior to a single-pigment paint. Other tests showed that 10 to 25 per cent of talc, mixed with other pigments, produced a good paint.

#### TALC IN FIRE-RESISTANT PAINT.

Because of the fire hazards involved in the use of wooden shingles the National Lumber Manufacturers' Association, some years ago,

<sup>19</sup> Gardner, H. A., *Paint technology and tests*, 1911, p. 55.

began a search for a suitable fire-resistant paint. The problem was submitted to the educational bureau of the Paint Manufacturers' Association of the United States and work was started by Mr. Henry A. Gardner, at the Institute of Industrial Research, Washington, D. C., in collaboration with Dr. Herman von Schrenk, a timber expert, of St. Louis. The results of this work have been described by Heckel,<sup>20</sup> who gives the following formula for one of the colors as typical:

TABLE 5.—*Formula for a fire-resistant paint that contains talc.*

Pounds.	Substance.	Per cent.
	<b>Pigment:</b>	
10.60	Basic sulphate white lead .....	63.7
11.00	Zinc oxide .....	
33.00	Asbestine (magnesium silicate).....	
.50	Borax.....	
.90	Dry lampblack.....	
	<b>Vehicle:</b>	
24.00	Linseed oil.....	36.30
2.00	Liquid dryer.....	
10.00	Mineral spirits.....	
100.00		

In this formula "asbestine" forms 33 per cent of the total liquid pigment by weight or 51.8 per cent of the solid constituents. Heckel describes this paint as "asbestiform" and assumes that since "asbestine" is magnesium silicate it must be the chrysotile variety of asbestos. "Asbestine," however, is not asbestos but is a trade name for a fibrous variety of talc mined in the Gouverneur district, St. Lawrence County, N. Y. This rather natural error credits to asbestos many desirable properties that are characteristic of talc.

Heckel, in the same article, says:

While the tendency of paint manufacturers during the past decade has undoubtedly been to curtail the high percentages of inert pigments formerly common, there is no doubt that recognition of their technical value has led to a more intelligent and legitimate use of them in many products. This is particularly true of the asbestiform type of inert pigment, demand for which has probably multiplied within the past 8 or 10 years. While there are available no statistics to corroborate this conclusion, it is nevertheless a fact familiar in the industry; a fact which is further substantiated by the common appearance of the term "asbestine," or "magnesium and aluminum silicates" on formula labels. In prepared paints of all types it appears to have won general favor; while for the other uses indicated at the beginning of this paper, other types of inert pigment appear to retain the preference.

The prevailing percentage of "asbestos" in high-grade paint formulas averages about 15 per cent, regardless of color, indicating that the pigment is introduced because of its physical qualities rather than as a diluent or cheapener.

The only practical objection I have ever heard advanced against this type of pigment was, again, due to its form. The slender fibers are said to have a

<sup>20</sup> Heckel, G. B., *Asbestos in the paint industry*: Asbestos, vol. 2, July, 1920, pp. 5-10.

tendency to "upend" themselves, forming a minutely rough surface. I have noted this effect myself in connection with several tests, but hardly regard it as a serious practical defect.

In conclusion, an inert pigment of this type would appear to leave nothing to be desired on the score of chemical stability, while possessing, from its form, certain valuable properties belonging to it alone.

Diller<sup>20</sup> says, "Some of the large producers have one or more trade names, such as verdolite, asbestine, agalite, and talclay, by which their special products are known in the market, but all these products may be included under commercial talc."

In the interest of the talc industry as a whole, it is regrettable that such trade names should be used; they cause confusion and lead to mistakes like that noted above. Talc has so many serviceable properties and can be utilized in so many different industries that the general adoption of its proper name, talc, is highly desirable, commercially as well as mineralogically.

Another fact brought out by Heckel, confirming recent experience of talc producers in New York, is that the fibrous variety of talc, contrary to popular belief, is not always most desired by paint manufacturers. In certain types of paint fibrous talc is an advantage, but in other types it has the disadvantage mentioned above besides being too bulky for its weight. Heavy, granular talcs are often specified by paint manufacturers as distinguished from light, fibrous talcs. Practically all talcs are fire resistant and many of the talcs on the market to-day could probably be used in this new paint.

The importance of this new use, as Heckel points out, is evident from the fact that—

The copyrighted title "Pamak" was given to the line and some 50 manufacturers were licensed to manufacture and sell it, under rigid specifications, using the association's trade-mark. The Lumber Association has been enthusiastic in its indorsement of this product, which will probably be pushed vigorously as soon as final decision on its classification has been made by the Underwriters' Laboratory, where it is now under test.

This use will probably afford talc producers a new market of importance, but it can only be won by removing the erroneous opinion held by some persons in the paint industry that asbestine is ground asbestos. All talcs should be tested by a uniform series of tests and the properties of talc made known to the public.

#### GLASS.

An important use of talc in Germany, which may become important in the United States, is to replace cryolite in the manufac-

<sup>20a</sup> Diller, J. S., Talc and soapstone: U. S. Geol. Survey, Mineral Resources of the United States, 1912, pt. 2, p. 1147.

ture of opalescent or alabaster glass. The following formulas<sup>21</sup> indicate the relative quantities of talc necessary for successful use as an opacifying agent.

TABLE 6.—*Formulas for opacifying agents.*

Number.	Substance.	Parts.
1...	Sand.....	100.0
	Soda ash.....	35.5
	Lime.....	10.0
	Salt peter.....	5.0
	Talc.....	16.5
	Fluorspar.....	3.0
2...	Sand.....	100.0
	Soda ash.....	38.5
	Lime.....	8.0
	Talc.....	14.5
	Fluorspar.....	4.0
	Arsenic.....	0.5
3...	Sand.....	100.0
	Soda ash.....	36.0
	Lime.....	8.0
	Talc.....	20.0
	Salt peter.....	8.0

## LIME PLASTERS.

Tals that have a good slip may be used in lime plasters. High-calcium limes have many advantages not possessed by magnesian limes when used in plasters, but they do not spread as smoothly or freely under the trowel, and have a higher drying shrinkage. It might be possible to introduce into a high-calcium lime a certain percentage of a white talc with a good slip, resulting in a plaster that would work as easily as a magnesian-lime plaster. In addition the talc filler if finely ground would tend to fill up the voids in the finished plaster wall and decrease the drying shrinkage. It is reported that lime producers have been seeking some method of improving high-calcium lime plasters, but have not solved the problem.

## LAVA GAS-TIPS AND ELECTRICAL INSULATION.

The term "lava" was first used as a trade name for block talc that had been subjected to heat treatment, but it is now also applied to articles made from a synthetic compound which may contain little or no talc.

The valuable properties of finished lava are great hardness and tenacity, resistance to high temperature and to acids and alkalis, great compressive strength, and high dielectric strength. It is harder than glass, has a compressive strength of 20,000 to 30,000 pounds a square inch; is not affected by heat below 1,100° C.; is unaffected by alkalies or acids except hydrochloric, which attacks it

<sup>21</sup> Schnurpfel, ———: [Review for glassworks], vol. 4, 1920, p. 685.

but slowly; and its dielectric strength is 75 to 250 volts per thousandth of an inch in thickness.

Lava is used in a great variety of forms for gas tips and burners and for electrical and heat insulation. As all the machining is done before the talc is baked, an almost infinite variety of forms may be made. Such forms are limited in size only, as articles not much over 12 inches in length can be made satisfactorily of true lava.

Talc suitable for the manufacture of lava <sup>21a</sup> must be fine grained, homogenous, compact, fairly soft, and without cleavage, or the cleavage must be very poor; it must contain little or no water, and must be free from grit and low in iron. Massive talc for this use is found in British India, Italy, France, Germany, and the United States. One of the characteristics of the highest-grade talcs is that a surface scraped by a sharp knife has a semipolished appearance. This property is best exhibited by the Indian, Italian, and German talcs. Fineness of grain and freedom from grit are essential if very small holes or slots are to be cut. Iron as an impurity lowers the dielectric strength. Included moisture causes the talc to swell and split during baking.

Lava manufacturers buy talc cut to size in small cubes or in large, roughly squared blocks 12 to 18 inches in diameter. As many of the shapes of lava are made to order, the large blocks are held in stock for cutting into special sizes. The small blocks, cut approximately to the outside dimensions of the finished articles, are placed one at a time in small, high-speed lathes where the preliminary cutting is done. They then pass to a succession of lathes, drills, and saws, where the blanks are turned, threaded, drilled, and slotted. After the machining is done the lava in the green state is placed in small ovens or kilns and heated by electricity or gas. There they are subjected to a temperature of about 1,100° C. or 2,000° F. for 24 to 48 hours. There is practically no shrinkage in the baking process, consequently it is possible to manufacture articles in which accuracy of size is important. After removal from the kiln the lava articles are allowed to cool and then are carefully examined and tested. Gas-burner tips are usually mounted in brass or nickel-plated holders.

Composition or synthetic lava is made from ground talc or other material mixed with a suitable binder. The resulting mass is thoroughly mixed and is then formed under high pressure into rods, slabs, or tubes. These blank forms are first air-dried, then kiln-dried at a moderate temperature. The resulting material may be machined and baked by the methods used for true lava. Composition lava is lighter in weight and more porous than true lava but is more suitable for some purposes.

<sup>21a</sup> See Diller, J. S., Fairchild, J. G., and Larsen, E. S., High-grade talc for gas burners: *Econ. Geol.*, vol. 15, 1920, pp. 665-673; also, summary in *Mineral Resources*, U. S. Geol. Survey, Pt. II, 1920, pp. 211-213.

Most of the best talc for lava manufacture in the past has been imported, but it seems probable that domestic sources may be more widely utilized in the future. Further research in the field and laboratory will doubtless develop new sources of this grade talc, and also new uses for the lava.

### THE TESTING OF GROUND TALC.

The suitability of ground talcs for special uses depends closely on physical and chemical properties. In spite of this fact there has been little scientific investigation to devise quick and accurate tests for determining these properties. The chemical properties of talc are inherent and may not be altered or modified except by selective mining or by chemical processes not practical in the present status of the industry. The determination of chemical properties is not as important for most uses as that of physical properties, although chemists in some industries may unduly insist on certain chemical properties. Physical properties depend both on mineralogical characteristics and on methods of grinding and sizing, and thus may be partly changed or modified in practice.

So little is known of the chemistry and physics of talc utilization that its purchase and sale is governed more by individual opinion and prejudice than by accurate, standard tests. Not only do unwarranted price fluctuations result but both the producing and consuming industries are injured by the creation of false views on the suitability of talc for particular uses. It thus seems important that present tests be standardized and made uniform for the whole industry, and that new tests be devised to fill the existing gaps.

#### PHYSICAL TESTS.

Some of the important physical properties are: (1) Size of grain; (2) shape of grain; (3) hardness; (4) color; (5) slip; (6) specific gravity; (7) grit—size, nature, and percentage of oversize; (8) absorptive power; and (9) behavior under heat.

#### SIZE OF GRAIN.

The importance of knowing accurately the average grain size is now generally recognized, although a few producers still make no sizing tests. The most efficient plants use a series of standard wire screens ranging up to 200-mesh and one uses a 300-mesh screen. As the approximate fineness of the talc to be tested is usually known, only one screen is employed, although for accurate sizing of non-uniform material a series of screens is needed. The 200-mesh screen has been generally adopted as the governing screen for most finely ground talc.

A definite quantity, 10 or 20 grams, is carefully weighed out and placed on the screen. Several methods of forcing the talc through the screen are in use. It may be shaken or jarred through, rubbed through with the fingers, or forced through by a fine water spray. The first method is the most common, though it is very slow for fine material; the second method, rubbing, is useful only as a rough, quick test, for the rubbing action not only wears out the screen but stretches the wires apart so that the sizing is not accurate. The water-spray method is not generally used, but is quicker than the shaking method, is less tedious, and is very satisfactory. A nozzle is used which will fit on an ordinary water faucet, designed to produce a very fine spray under low pressure. An alternative method is the use of a flexible rubber tube, one end of which may be pressed together with the fingers to produce the desired spray. The screen carrying the talc is slowly passed under the spray, all the fine material being rapidly washed through. Then the screen is put on a warm plate or steam radiator when the talc is thoroughly dried. It is then brushed onto a paper and transferred to a balance pan for weighing.

As screen makers use different sizes of wire, with consequent differences in the size of the openings, strict accuracy in reporting tests with screens requires that the size of the screen opening be expressed in fractions of an inch or in millimeters. Not only should the percentage of material passing a 200 or 300 mesh screen be determined but also the screen mesh through which all the material passes. The demand for 300-mesh material is growing and accurate sizing tests, standard for all talc producers, are becoming necessary.

The most accurate method of obtaining grain size is by actual measurement with a microscope equipped with a micrometer eyepiece. The average of a number of measurements gives a close approximation to the average size of the particles. This method, though useful, is not now used commercially.

#### SHAPE OF GRAIN.

No tests to determine the shape of talc grains are now made commercially, although the shape undoubtedly has an important bearing on utilization. The predominant shape may be round or flat, needle-like or lath-shaped, smooth or irregular. One shape may be best suited for paint, another for paper, and another for rubber. Grain shape may be readily determined with a microscope.

#### HARDNESS.

The hardness of crude talc is often roughly determined by scratching with the finger nail, a knife, or a coin, but no tests are made on the hardness or abrasive action of powdered talc. Hardness may be



an important factor for some uses—as in lubricants and polishing agents, and as a filler for phonograph records—but no tests for the determination of the hardness of ground talc have been devised.

#### COLOR.

A very pure white is demanded by many consumers of talc, but no standard, accurate method of detecting slight differences in color has been devised. Practically all talc producers make a rough comparative test by the unaided eye, usually comparing talcs to a sample taken as a standard, which varies for each producer and consumer. The talc is either placed in little heaps or is spread out flat with the finger or a knife, on the hand, or on blue or white paper. Probably the best method now in use consists of forming two small piles of the material used as a standard and of the talc to be tested, pushing the heaps close together and flattening them with a spatula so that the contact between the heaps is a smooth straight line. If the talcs are then wet with a few drops of turpentine, slight differences in color may be detected; but even this method is not satisfactory, as no standard samples are used in common by the whole industry, and differences in light and in human perception give different results. Often the accurate determination of slight color differences is of utmost importance, for color is not only an index of value but frequently is an indicator of proper methods of grinding. Poor color is not always due to impurities, but may be due to insufficient or improper grinding. Thus a yellow hue in a talc was attributed to iron, but microscopic examination proved that finer grinding would eliminate most of the objectionable tint. Finer grinding of many talcs improves the color. A uniform and standard method for the determination of color should be devised and adopted.

#### SLIP.

Slip is a term applied to the relative smoothness or greasiness of ground talc. Good slip is desirable for some uses and unimportant or even objectionable for others. It is roughly determined by rubbing the talc between the fingers or in the palm of the hand. This test is of little value in the accurate comparison of talcs. A method of uniform testing of slip would be very desirable.

#### SPECIFIC GRAVITY.

The specific gravity of pure crude talc varies from 2.55 to 2.78, but the apparent specific gravity of ground talc, as indicated by its behavior in water, oil, or other liquids, varies between much wider limits. This divergence is due to the facts that other heavier min-

erals often occur with talc and are ground with it; that grains of different shapes have different rates of settling in liquids; and that very finely ground talc has colloidal properties that tend to keep it in suspension in liquids. Some paint manufacturers desire a heavy talc that will sink in water, and others demand a flaky or fibrous talc that has a tendency to say in suspension and not cake down solidly. Some divergence is due to differences in specific gravity and some to shape and size of grain, surface tension, and other factors. It would be very desirable, therefore, to devise uniform methods of determining not only the specific gravity but also the other properties that affect the behavior of talc, both as a dry filler and in liquids. No such tests are now in use.

#### GRIT: SIZE, NATURE, AND PERCENTAGE OF OVERSIZE.

Grit or oversize in ground talc is objectionable for most uses. Sometimes the grit is a siliceous or other impurity, and sometimes it is merely insufficiently ground talc. In some products siliceous impurities would be very harmful, whereas oversize talc would not be objectionable, as in lubricants. In other products, oversize of any nature and siliceous impurities, even if finely ground, would be injurious, as in paper manufacture. It is, therefore, important to know the size, nature, and amount of grit or oversize present in ground talc.

The screen tests previously described may be used to determine the amount of oversize, but the nature and size can be determined only under a microscope. If the grit is siliceous and not oversize talc, its presence can be detected by "gritting" between the teeth or by rubbing between the finger nails. This method is a crude one and does not determine the nature, size, nor relative amount present. Another method in use is to flatten out a small pile of talc, so that it presents a smooth surface, by pressing or rubbing with a piece of plate glass. This method will detect only coarse impurities present at or close to the surface of the pile. No test or series of tests now in use make accurate and uniform determinations of this property. A careful microscopic examination is of great assistance, but is not wholly satisfactory.

#### ABSORPTIVE POWER.

The absorptive power of ground talcs is a property that has never been determined commercially, but in many uses of talc it is more important than has been thought. In the manufacture of paints the oil absorption of the various materials is very important, but even for this use talc producers do not determine the absorption. When talc is used in the manufacture of paper its absorptive power has an

important effect on retention. When used as a deodorant, a decolorizer, or a degreasing agent the absorptive power of talc is very important. The oil-absorption test of the paint chemist might be used to determine the absorptive power of talc in general for various uses. This subject is not well understood and is worthy of careful study.

#### BEHAVIOR UNDER HEAT.

Massive talc and soapstone have long been used as both heat-resisting and heat-retaining agents, and ground talc has been used in pipe-covering compounds and in fireproof paint. The value of talc as a fireproofing material is becoming better known, and its use for that purpose is increasing. When used as a ceramic material in the production of china and porcelain the behavior of talc under high heat is of great importance. Some talcs contain mechanically combined water; others contain lime, dolomite, iron, or other impurities, which may alter the color, destroy the slip, or cause the talc to swell under heat. Pure talcs vary in melting point and in behavior under high temperature in ceramic compounds. Standard and uniform tests for the behavior of talc under heat should be devised.

#### CHEMICAL TESTS.

Pure talc contains theoretically 63.50 per cent silica ( $\text{SiO}_2$ ), 31.70 per cent magnesia ( $\text{MgO}$ ), and 4.80 per cent water ( $\text{H}_2\text{O}$ ), but talc of exactly this composition is practically never found in nature. Impurities often found are alumina ( $\text{Al}_2\text{O}_3$ ), iron oxide ( $\text{FeO}$  or  $\text{Fe}_2\text{O}_3$ ), iron sulphide or pyrite ( $\text{FeS}_2$ ), lime ( $\text{CaO}$ ) usually as calcite ( $\text{CaCO}_3$ ), an excess of magnesia as dolomite [ $(\text{CaMg})\text{CO}_3$ ], an excess of silica as quartz ( $\text{SiO}_2$ ), and sometimes manganese oxide ( $\text{MnO}$ ). For some uses none of these substances are objectionable, but for most purposes several or all are harmful. Silica and alumina are inert but may form grit. Iron oxide and sometimes iron sulphide (in paper) injure the color. Manganese oxide, often found, may discolor the talc. Small amounts of lime or dolomite for many uses are not objectionable. Some paper chemists object to lime on the ground that it causes foaming and tends to neutralize the sulphite solution; other paper manufacturers do not object to carbonates.

#### IMPORTANCE OF STANDARD TESTS.

The presence of some of these impurities can be easily detected under the microscope, but the relative percentages can be determined only by chemical analysis. Simple quantitative tests for iron and for carbonates are usually adequate, a complete chemical analysis being unnecessary.

In addition to a chemical analysis the determination of chemical behavior in different solutions, for example, the resistance to acids and alkalis, and the determination of such physicochemical properties as colloidal suspension in water or oil are often important.

As no uniform tests for the properties of talc have been devised, and the grading of talc is not uniform, no comparable price quotations from the different producing districts are possible, and consumers depend almost solely on the word of the salesman or jobber for a statement of grade. On the other hand, improperly prepared talcs entirely unsuited for certain uses may be sold by irresponsible dealers to the detriment of the industry.

The determination of and agreement on a series of standard tests would go far toward stabilizing the industry, would form a basis for a comparison of the relative efficiency of various methods of grinding and preparation, and would aid a logical extension of uses.

#### COMMERCIAL GRADES OF TALC.

The most important commercial grades of ground talc are generally sold as 200-mesh products, but wide variations occur in the products actually delivered by mills. In the best mills the grades are expressed by the percentage of material that will not pass through a 200-mesh screen; thus, 0.2 per cent on 200, 0.5 per cent on 200, or 1.5 per cent on 200. Some producers merely state that their talc is 200-mesh, although an appreciable proportion may not pass a 150-mesh or even a 100-mesh screen. Variations in some of the commercial grades are shown in Table 7, page 88.

A point often overlooked in grading talc is the relative proportion of the sizes finer than 200-mesh. For many uses a large proportion of exceedingly fine grains is necessary. Specifying 200-mesh talc simply requires that practically all the talc should pass through this screen. In tests 2 and 6 in Table 7 approximately the same proportion passed the 200-mesh screen (98.20 and 98.26 per cent), but there was a difference of practically 10 per cent (96.72 and 86.75 per cent) in the amounts that passed a 300-mesh screen. These divergencies, which are not detected when only a 200-mesh screen is used for testing, result from differences in methods of milling and from inherent differences in the talcs. In many instances, talcs have been found unsuitable for various uses when the real reason has been that the proportion of impalpable dust was too small. Testing screens can now be obtained up to 300-mesh, and full use should be made of them; but in order to understand the behavior of filler materials one must eventually be able to estimate the relative percentages of 400, 500, or 1,000 mesh material, if screens could be made of such fineness. A

microscopic method for doing this has been devised, which it is hoped can be simplified for commercial testing.

TABLE 7.—*Screen tests on commercial grades of talc.*

[Expressed in percentages.]

Screen mesh.	No. 1.		No. 2.		No. 3.		No. 4.	
	On.	Through.	On.	Through.	On.	Through.	On.	Through.
100.....	0	100.00	0	100.00	0	100.00	0	100.00
150.....	Trace.	99+	0	100.00	0	100.00	0	100.00
200.....	1.60	98.40	1.74	98.26	0.55	99.45	0.85	99.15
240.....	1.67	98.33	2.18	97.82	.55	99.45	1.23	98.77
300.....	4.49	95.51	3.28	96.72	2.05	97.95	6.41	93.59

Screen mesh.	No. 5.		No. 6.		No. 7.		No. 8.	
	On.	Through.	On.	Through.	On.	Through.	On.	Through.
100.....	0	100.00	0	100.00	0	100.00	0	100.00
150.....	0	100.00	0	100.00	0	100.00	0	100.00
200.....	0.50	99.50	1.80	98.20	0.75	99.25	0.01	99.99
240.....	2.15	97.85	3.30	96.70	.75	99.25	.01	99.99
300.....	6.55	93.45	13.25	86.75	4.67	95.33	.015	9.985

No. 1. New York fibrous talc, milled in tube mills; no sizing.

No. 2. New York fibrous talc, milled in conical mill and tube mill; air separation.

No. 3. New York granular talc, milled in conical mill; no sizing.

No. 4. New York granular talc, milled in Raymond roller mill; air separation.

No. 5. Vermont foliated talc, milled in Raymond roller mill; air separation.

No. 6. Canadian foliated talc (micaceous), milled in short tube mills and bolted through 180-mesh cloth.

No. 7. California granular talc, milled in Raymond roller mill; regular air separation.

No. 8. California granular talc, milled in Raymond roller mill; dust-collector product.

In the fine grinding of talc and other materials the consumption of power and the cost of grinding increase, whereas the capacities of grinding machines decrease, not in direct proportion to the fineness but at a much higher rate. In grinding the last few grains to pass a 200-mesh screen, all the rest of the material at the same time is ground much finer. See tests 7 and 8 in Table 7. In test 8, 99.99 per cent and in test 7, 99.24 per cent passed 200-mesh. But in test 8, practically 99.99 per cent also passed 300-mesh, whereas only 95.33 per cent passed 300-mesh in test 7. In grinding 0.74 per cent to pass 200-mesh, therefore, all the rest of the material was ground so fine that all of the minus 200-mesh product in test 8, except 0.005 per cent, was also minus 300-mesh. For this reason the mere statement that 99.5 per cent of a finished talc will pass a 200-mesh screen is no real indication of the true fineness. It is also evident that the differences between grades classed as 0.2 per cent on 200, 0.5 per cent on 200, and 1.5 per cent on 200-mesh are far greater than indicated by these percentages.

Other commercial grades of ground talc, such as are used for the surfacing and dusting of prepared roofing, are much coarser. There

are apparently no standards for these grades, but they are prepared on order for each customer. Typical grades are through 20 on 40 mesh, through 40 on 60, through 40 on 100, etc. These grades are commonly made on inclined impact or vibrating screens.

The grading of talcs based on color and on freedom from lime and grit is discussed on pages 84-86.

## REPRESENTATIVE MINES AND MILLS.

### INTRODUCTION.

On the following pages are descriptions of the mines and mills of most of the talc-producing companies in the United States and of some of the companies in other countries. Most of the data have already been published in mimeographed form by the Bureau of Mines, but are included here for the sake of completeness. Most of the descriptions apply to conditions at the time of the writer's visit, but several descriptions embody brief additions and changes to bring the material to date. As some of the mines and mills were examined in 1919 and others in 1920, important changes may have been made that have escaped the writer's notice.

### TALC MINING IN VERMONT.

#### RELATIVE IMPORTANCE OF THE VERMONT DISTRICT.

The talc and soapstone deposits of Vermont have been worked for nearly 100 years, but all early efforts were directed toward producing slabs for foot-warmers and similar uses. Although soapstone of good quality occurs at several places, much of the material first utilized was really talc and was not massive enough to cut successfully. The grinding of talc in Vermont began about 1902 and has since grown continuously. Statistics compiled by the Geological Survey show that the production of talc in Vermont increased from 8,978 short tons valued at \$65,525 in 1905 to 93,960 short tons valued at \$625,150 in 1917. Until 1917, New York was the leading producer in both amount and value, with Vermont second; in 1917, Vermont took the lead in amount, although not in value, its output being over 47 per cent of the total amount produced in the United States and over 35 per cent of the world's production. This increase in production will probably continue, possibly at a decreased rate, for the reserves of talc in Vermont are large.

#### LOCATION OF DEPOSITS.

Active talc mines and mills in Vermont are found in four districts: Chester and Rochester, Windsor County; Waterbury, Washington

102740°—23—7

County; and Johnson, Lamoille County. These mines and mills are distributed as shown in the following table:

TABLE 8.—*Distribution of talc and soapstone mines and mills in Vermont.*

District.	Town.	Mineral.	Mines or mills.	Product.
Chester.....	Chester.....	Talc.....	1 mine, 2 mills.....	Ground talc.
	Chester.....	Soapstone.....	1 quarry, 1 mill.....	Soapstone slabs.
Rochester.....	Windham.....	Talc.....	1 mine.....	Crude talc.
	Taleville.....	do.....	3 mines, 1 mill.....	Ground talc.
Waterbury.....	East Granville.....	do.....	1 mine, 1 mill.....	Do.
	Moretown.....	do.....	do.....	Do.
Johnson.....	Moretown-Fayston.....	do.....	do.....	Ground talc.
	Johnson.....	do.....	do.....	Do.

Many other deposits of talc and soapstone are known in Vermont, some of which have been worked, but those listed above are the only ones that have survived and are producing on a commercial basis. The closing down of many mines and quarries, for example those at Perkinsville, Stockbridge, Reading, Cavendish, and Athens, has been attributed to exhaustion of the deposits, poor grade, long haul to the railroad, poor management due to lack of knowledge of mining methods, and failure to consider talc mining strictly as a business proposition. The companies now operating with success have realized the possibilities of their industry, and have invested capital enough in equipment and personnel to establish themselves on a firm business basis.

#### MODE OF OCCURRENCE.

Vermont talc ranges in hardness and texture from soft, green, translucent, and foliated to moderately hard, compact, and massive; and in color from white, through light green and gray green, to a dark mottled green. Practically no fibrous talc is found in the State. Foliated talc occurs in small quantities, but is not of commercial importance, because, although it is soft and very pure, it is difficult to grind properly by the machinery now in use, as it breaks into thin plates or laminæ. The massive is the only variety of pure talc important in Vermont. A closely associated mineral, known locally as "grit," is usually mined with the talc and often forms the most important part of the output. "Grit," as the term is used in Vermont, refers solely to the talcose, not gritty, material occurring with the pure talc.

The talc deposits usually form large lenses standing more or less vertical, striking nearly north and south, between walls of serpentine and talcose schists. Pure talc is generally found only along the walls, its thickness ranging from a few inches to 20 feet or more. The core is usually "grit," but in one deposit is serpentine. Between the talc and the true wall rocks lies a dark green chlorite, known locally

as "black wall." Occasional inclusions or horses of chlorite within the talc or grit are known as "cinder." Jacobs has shown both by microscopic examination and chemical analysis that "grit" is essentially a mixture of talc and dolomite. It usually contains talc enough that when ground the resultant material has a good slip. Jacobs<sup>22</sup> gives an excellent account of the occurrence, origin, and geology of Vermont talc deposits.

The chief grades and varieties of talc and soapstone sold from the Vermont districts are as follows:

Talc, ground: 20 to 100 mesh (average 40 to 60 mesh); 100 to 200 mesh; 200-mesh; 350-mesh or finer (air-separator dust).

Talc, cut into metal-workers' crayons.

Soapstone, cut into large slabs for laundry tubs and other purposes.

### DESCRIPTION OF MORE IMPORTANT PLANTS.

#### VERMONT TALC CO., CHESTER, VT.

The mine of the Vermont Talc Co. is in the town of Widdham, 11 miles by road from the mill, which is on the tracks of the Rutland Railroad at Chester. The size of the talc lens worked is not accurately known. Its width has been estimated from 110 to 242 feet, and it has been mined to a width of 56 feet in pure talc. A section across the lens at one point beginning at the east black wall shows 40 feet of grit, 47 feet of talc, and 50 feet of grit, but no west "black wall" has been found. A crosscut through the west vein of grit would probably strike another vein of talc and then the west black wall.

The deposit was originally worked as an open cut in the vein, but eventually a shaft was sunk in the talc, following down the hanging-wall contact between talc and grit. The shaft at the top dips at an angle of 75° but changes to 60° following the changing dip of the grit walls. About 75 feet below the surface a level was cut to the north and to the south for a length of about 150 feet. Several short crosscuts to the grit walls were cut, and then the shaft was deepened to 100 feet and a new level started. The shaft is now 120 feet deep with the top level temporarily abandoned, the main production coming from the 100-foot level. As no grit is being mined at present, the contacts between the talc and the grit walls are closely followed. In starting a level a drift is carried along the hanging wall, 6 to 7 feet square, and the back arched over. No timber is used. Then a stope is started 15 to 20 feet below, 15 to 20 feet wide, and carried along as a breast stope. The talc and grit walls stand well, and high, wide stopes may be cut without timbering if the back is arched. Drilling is done with a jack-hammer type drill using hollow steel. One and a quarter to two hours' drilling breaks the average day's output of 35 to 40 tons.

The problem of mine drainage is not troublesome. A small steam-driven pump with a 3-inch suction is used for one and one-half hours a day. Shaft stations and mine levels are not illuminated; the miners use candles.

The broken talc is loaded into small cars, trammed to the shaft, dumped directly into a skip, and hoisted to the surface. If the talc is dry, the skip dumps directly into a small stock-pile car, which is trammed by hand to the stocking trestle, and dumped. One end of the stocking trestle is under a shed

<sup>22</sup> Jacobs, E. C., Report of Vermont State geologist, 1913-1914, pp. 382-429. See also Report of Vermont State geologist, 1915-1916, pp. 232-280.



roof and is provided with small, sloping-bottom bins, from which wagons and trucks may be loaded directly. If the talc from the skip is wet, it is dumped upon a sorting floor and shoveled over a coarse stationary screen. The screen oversize is considered dry and is trammed to the stock bins; the wet fines are trammed to the far end of the stocking trestle and dumped in piles to dry. When the moisture evaporates from the surface of the pile, the dried material is shoveled into wagons or motor trucks.

The surface plant consists of a 35-horsepower locomotive-type boiler which furnishes steam for the mine pump and the surface machinery, a small, single-stage air compressor, and a small, single-drum geared hoist.

The crude talc is hauled from the mine over fair country roads 11 miles to the mill in motor trucks or wagons. (See Fig. 5.) Two 2-ton trucks are owned by the company. These trucks make an average of two round trips a day, and carry over 5,000 pounds a load. Wagons hired on contract average about 3 tons a load. The grade from the mine to the mill is strongly in favor of the loaded wagons and trucks.

At the mill the talc is unloaded by hand into a long storage shed, down the center of which runs a narrow-gage track; the crude material is then trammed by hand on small flat cars into the mill, and shoveled into a 12 by 18 inch jaw crusher. At this point all waste rock is picked out and discarded. The crusher product is then reduced further in size by a Sturtevant rotary crusher and elevated into two 20-ton storage bins at the top of the mill.

From the bins the talc may go to either or both of two Raymond low-side, 5-roller mills. Each mill is equipped with the Raymond system of air separators and dust collectors. When the talc is ground fine enough it is drawn by exhaust fans from the roller mills into the conical air separators.

The coarser particles return to the roller mills; the finely ground talc is collected and carried by bucket elevators to a 20-ton storage bin. The exhaust air from separators is forced through Raymond dust collectors and the talc is sacked by hand. The finished product is drawn from the bin by gravity and packed in paper or burlap sacks by Howes talc packers. Different grades of talc may be made by regulating the pressure in the air-separation system by opening or closing dampers or regulator blades in the air mains. The usual grades made range from 100 to 200 mesh.

The mill is electrically equipped throughout, alternating current being supplied by local electric-power companies. Individual drives are used on all important machines.

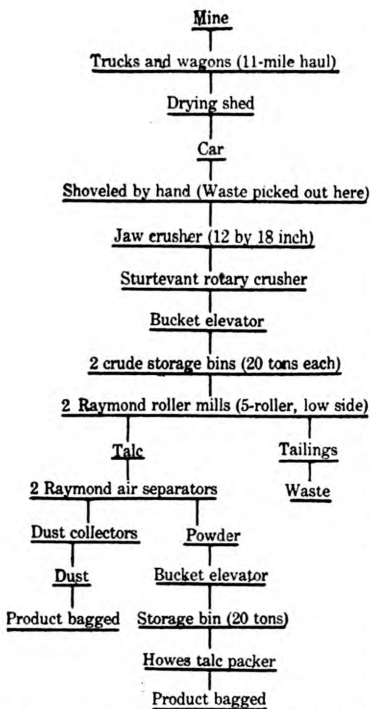

FIGURE 5.—Flow sheet of mill of Vermont Talc Co., Chester, Vt.

## EASTERN TALC CO., ROCHESTER AND EAST GRANVILLE, VT.

The Eastern Talc Co., the largest talc-producing company in Vermont, has a mine and a mill at East Granville and three mines and a double mill near Rochester. The three mines which supply the Rochester mills are about  $4\frac{1}{2}$  miles north of the mills. Mines No. 2 and No. 5 have been worked for many years. Each was opened by a small shaft that followed down the walls of the talc body. A new mine, No. 8, has been opened on a lens recently discovered by diamond drilling. Originally only pure talc was removed, and as the talc veins were usually less than 15 feet thick, mining was by overhand stoping from stulls.

When the grit core between the talc veins was found to be usable, a large amount of material was made available in the old mines and a new mining system was developed. All the mines are opened on a series of talc lenses in a line running roughly north and south, the axis of each lens being practically parallel to the schistosity of the rocks. The lenses range in thickness from 18 to 60 feet. The largest lenses are over 400 feet long and have been opened to a depth of over 450 feet, the bodies seeming to grow thinner below 300 feet. As the older deposits neared exhaustion vigorous development was undertaken, both by diamond drilling and by sinking, drifting, and crosscutting, with the result that large reserves—over 2,800,000 tons according to published reports—have been blocked out. The largest body, that opened by the new No. 8 shaft, had little visible outcrop and was proved by drilling. As the No. 8 mine embodies the best features of the older mines, it alone is described.

Starting in the "black wall," a shaft was sunk along the strike at a dip of  $45^\circ$ . At the surface the shaft is timbered with round timber and lagged tight with round poles, but after the solid rock was struck no timber was used. The shaft comprises two compartments, a manway at the left and a skipway at the right. At a depth of less than 100 feet talc was encountered, and the remainder of the shaft is in talc. The solid rock section of the shaft is cut 15 to 20 feet square.

## MINING METHOD.

The ore bodies, as everywhere in Vermont, are very irregular in size, shape, and dip, making the devising of a standard mining method difficult. Practically no timber is needed for support. Some water is encountered, but pumping is not a vital problem. Both talc and grit drill easily and break well.

In the old mines the level interval was more or less irregular, but in the No. 8 mine the interval will be 175 to 200 feet. At each level crosscuts are run from the shaft to the limits of the body as defined by the "black wall." Then drifts are run from the ends of the crosscuts in each direction, following the walls to the limits of the body. Raises from both the drifts and crosscuts to the walls are put up at frequent but irregular intervals at an angle of  $45^\circ$  with the horizontal, branching and going to opposite walls at angles of  $45^\circ$  from the horizontal. The tops of adjacent raises are often connected. All openings are 10 to 15 feet square, not timbered. When the body or parts of it farthest from the shaft are developed by such openings, stoping begins.

Talc above the tops of the raises is mined by overhand stoping, which may cut through the level above, or a back pillar may be left. To insure safety great care is taken before leaving the back, as once left it is inaccessible. Stoping is then continued by underhand slicing or benching into the raises, the talc being worked out retreating toward the shaft, milling the ore into raises, and leaving large open stopes. As much black wall and cinder as possible is

left as pillars. In high stopes the direction of the raises is frequently changed to slow up the fall of large pieces of ore.

In shooting down the ore it is considered good practice, though much secondary blasting and hand breaking are required, to break out large pieces to avoid fines, which become saturated with water and must be dried at the mill.

There are no chutes at the foot of the raises, the rock being shoveled into small wooden cars of 18-inch gage. These are trammed by hand to the shaft and dumped into a rock bin, at the bottom of which is a measuring pocket

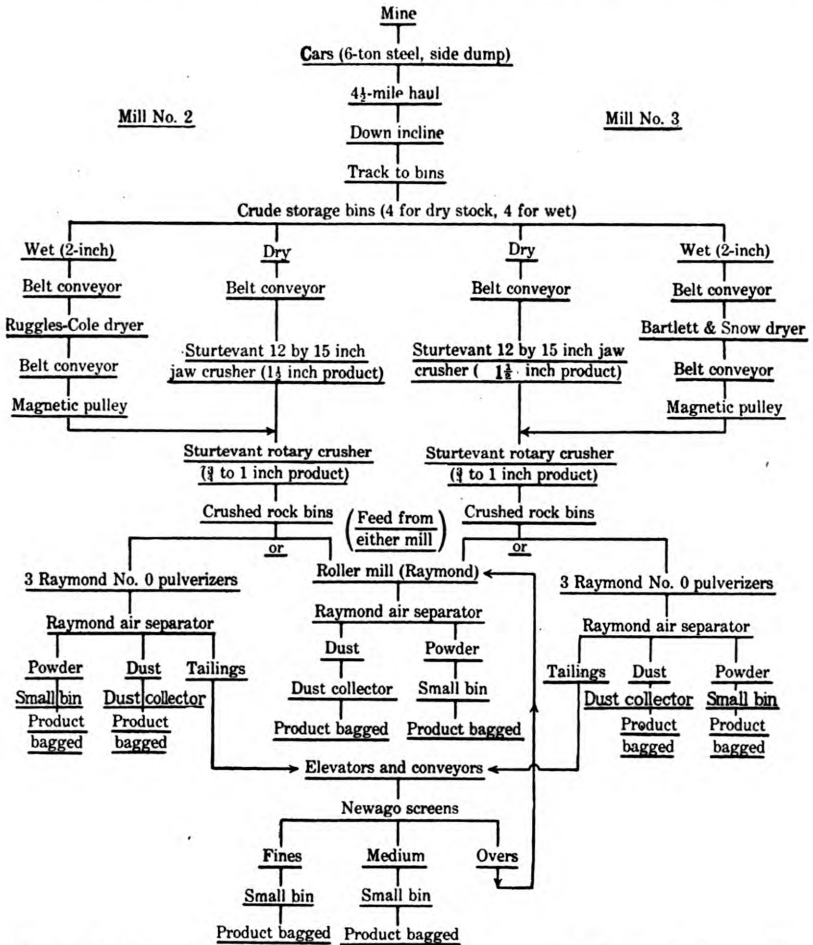

FIGURE 6.—Flow sheet of mills No. 2 and No. 3, Eastern Talc Co., Rochester, Vt.

with a counterbalanced tip-up spout. At the surface the talc is dumped automatically into a chute and over a 2-inch grizzly set at a flat angle. Here the waste is picked out and thrown into a waste chute, and the pure talc, distinct from the "grit" talc, is thrown into a talc bin. The fines go to the wet talc bins and the oversize "grit" talc to the dry talc bins.

From the bins the talc is drawn into 6-ton steel, V-shaped, rocker-dump, 36-inch gage cars, and hauled in trains of six to eight cars by a saddle-tank steam locomotive about 4½ miles to the top of an incline at the mill. The cars

are run onto an incline truck and lowered one at a time by gravity to a track at the top of the mill. Thence they are trammed by hand over a short track and dumped into the proper mill bins.

## MILLING.

Milling at this plant can be understood by a study of the flow sheet. Mills No. 2 and No. 3 are so arranged that they can be run together in making the same product, or separately in making different products. When making different products mill No. 2 is usually reserved for grinding the finer grades of pure talc. The two chief products are the 20 to 100 mesh, used principally in the roofing industry, and the fine sizes, 200-mesh with varying oversize tolerances, used in the paper, paint, and rubber industries.

The mill was run entirely by steam, but electric drive has been installed. Each of the most important machines has its motor connected to a circuit breaker and ammeter on a separate panel in the engine room. In this way the power used by each machine can be watched and checked continually, affording a means for comparing efficiency of machines and enabling an estimate of the cost of producing different grades of talc.

## GRANVILLE OPERATIONS.

The East Granville mine has been worked for many years, originally as an open quarry. Now it is worked underground from an adit about 1,000 feet long, entering the body along the strike about 200 feet below the surface at the deepest part. The deposit is a series of lenses, more or less in line, 15 to 50 feet wide and 50 to 400 feet long, sometimes adjoining and sometimes separated by distances up to 150 feet. The general field relationships are similar to those at Rochester and elsewhere in Vermont, except that the walls do not stand as well as at Rochester. Production is comparatively small, and little development is being done, except some diamond drilling both from underground and from the surface. The mining method is similar to that used at Rochester.

The ore is trammed in small mine cars and dumped into a bin holding 7 to 8 tons at the head of an aerial tramway, 1,400 feet long, which is equipped with two buckets; the load, going down by gravity, pulls the empty to the top.

At the mill the rock delivered by the tramway is dumped on the floor of the crusher room, and is forked to separate the wet fines, which are taken in wheelbarrows and dumped on a sheet-iron drying floor heated by coils of steam pipe beneath. When dry the fine is fed with the coarse dry talc into a 12 by 15 inch Dodge jaw crusher, which makes a 1 to 1½ inch product. This is further reduced to ½ by 12 inches by 12-inch Sturtevant rolls and then fed either to a Raymond four-roller mill or to a 36-inch Sturtevant vertical emery mill. The product from each mill is separated by the Raymond system of air separation into a finished product and a tailing. Newago screens separate the tailing into two finished grades and a tailing which is returned to be reground. The capacity of this mill is 50 tons a 10-hour day. About the same grade of products are made as at Rochester.

## MAGNESIA TALC CO., WATERBURY, VT.

The mine and mill of the Magnesia Talc Co. are in Moretown, near Waterbury. The talc deposit differs from that at Rochester, the east wall being serpentine instead of schist, and the west wall being schist. The center or core of the lens is of serpentine instead of grit talc, little grit being encountered. The greatest distance between two walls is about 125 feet; most of the talc

has been removed from between the core and the west wall, where the talc vein is 4 to 50 feet wide and dips 75 to 85° east.

The mine was opened by an adit, over 200 feet above the bottom level of the present mill, which followed the east wall for more than 500 feet. Later a second adit was driven about 150 feet below, also along the east wall. All of the talc is removed at present from the lower level. Crosscuts to the east wall from the lower adit showed that the serpentine core had narrowed to 27 feet, whereas the total width at a higher level was 125 feet.

The adit now being used enters the hill on a level with the top of the mill, and has a grade of 1 per cent, so that mine cars run to the mill by gravity. The first 300 feet of the adit was driven in waste, but thereafter it follows the west wall of the lens in good talc over 1,500 feet. The chief product is pure talc; many pockets of massive talc contain material suitable for pencils. Water makes the ground unstable and necessitates timbering in places. There is no uniform system of timbering, but stulls, props, or square sets, either with or without lagging, are used.

#### MINING METHOD.

As at Rochester, the variations in strike, dip, and thickness make a uniform mining method impossible. In general the method used is as follows: The adit is driven in talc along the west "black wall," cut about 8 by 8 feet, and timbered where necessary. In several places crosscuts through the serpentine core connect the adit with a drift along the east wall. The west vein dips 75° to 85° to the east, and the east vein 45° to 55° to the west along the lower adit level; local rolls and irregularities may reverse the dip.

Along the drifts raises are made at about 50-foot intervals; they branch in each direction at an angle of about 45° with the horizontal, and may or may not be joined at the top. They are usually cut square, the full width of the vein, except that, where the vein is wide, horses of "cinder" or bad walls may necessitate reducing the size. Where two adjacent raises join at the top a timber grizzly with 2-inch spaces may be put at the junction to allow the wet fines to run to one chute and the coarse, dry talc to another. At the foot of each raise the drift is timbered and lagged, and a chute with a vertical sliding gate installed.

Above the tops of the raises the talc is slabbed off, leaving large open stopes. Where "cinders" can not be left as pillars holes are drilled around, but not in them, and they are shot down in large blocks. This avoids mixing waste with the talc. In addition to the pillars of "cinder," occasional pillars of talc are left to support the ground. During stoping the drifts are advanced, following the spurs and irregularities of the body. Thus most of the talc is removed in large openings, and the robbing of pillars can be done only when the level is worked out and ready to be abandoned. No diamond drilling is done and comparatively small reserves can be blocked out in advance of mining.

#### MILLING.

From the chutes 24-inch gage wooden end-dump cars carry the talc to the mill, where it is dumped into crude-rock storage bins, two being used for dry and one for wet stock. The mill usually runs on dry stock, but when the wet bin is full dry feed is cut off and wet stock is fed. Below the bins is a belt conveyer, so arranged that it may receive material from any bin, which conveys the talc to a 12 by 15 inch jaw crusher. The crusher product is screened, further reduced in a Sturtevant rotary crusher, and elevated to bins. Two of the five stock

bins feed a Raymond roller mill and the others feed two Sturtevant vertical emery mills. The Raymond mill and Sturtevant mills' products are separated into finished products and tailings by two separate Raymond air-separation systems, the finished products are bagged by two Howes talc packers, and the tailings are fed to Newago screens, which make 60-mesh and 40-mesh products, and are bagged by hand; the tailings are reground in the emery mills. In milling wet material the under-size from the screen following the jaw crusher is fed to a Ruggles-Cole drier, dried, and elevated to the storage bins. In other respects the two processes are identical. (See Fig. 7.)

The massive pencil stock found in mining is sorted out underground, removed from the cars at the mill or from the belt conveyor below the bins, and taken to the pencil mill. The blocks of talc in the sawing rooms are squared off on two opposite sides with an 18-inch circular saw on a swinging arm which is pulled forward by hand, the talc block resting on a horizontal saw table. The faced block is then sawed with an 18-inch circular saw into slabs of the width of the pencils to be made. The slab saw and the pencil saws revolve in a fixed position, the talc being

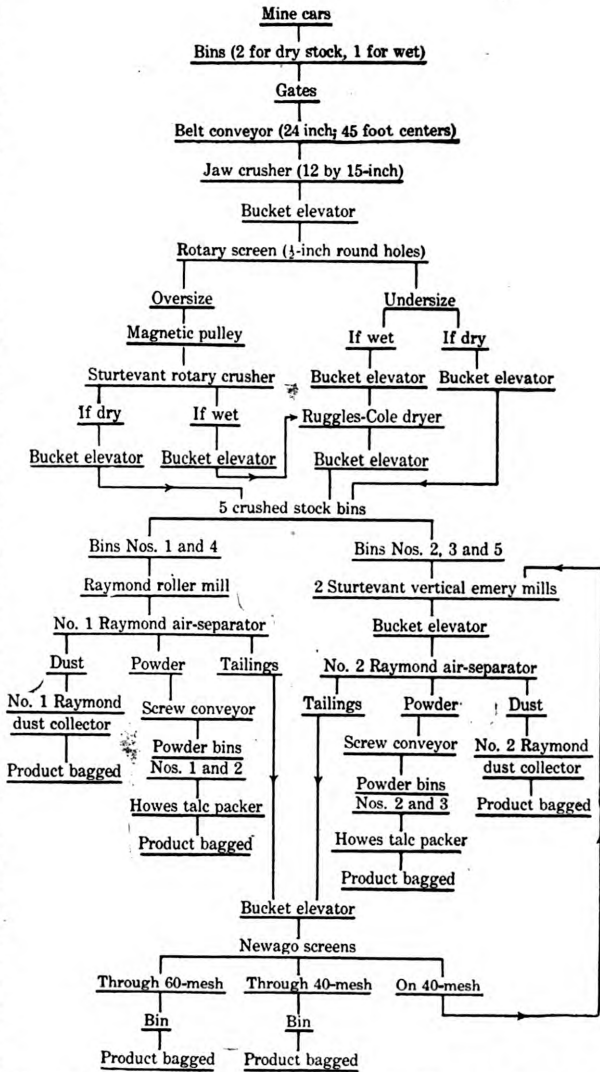

FIGURE 7.—Flow sheet of the mill of the Magnesia Talc Co., Waterbury, Vt.

pushed through by hand. The thin slabs are cut into the various sizes of pencils with 12-inch and 6-inch saws. Care is taken that the grain of the talc runs the length of the pencil. After sawing the pencils are sorted into two grades, No. 1 and No. 2. The No. 1 grade must be perfect in every way; No. 2 may be rougher and slightly splintered at the ends.

Generated at University of Michigan on 2023-02-13 11:27 GMT / https://hdl.handle.net/2027/uhug.30112104112039  
Public Domain, Google-digitized / http://www.hathitrust.org/access\_use#pd-gooole

Talc pencils at this mill are made in the following sizes: 5 by  $1\frac{1}{4}$  by  $\frac{1}{4}$  inch; 5 by  $1\frac{1}{4}$  by  $\frac{1}{8}$  inch; 5 by  $\frac{1}{2}$  by  $\frac{1}{4}$  inch; 5 by  $\frac{1}{2}$  by  $\frac{1}{8}$  inch; 5 by  $\frac{1}{2}$  by  $\frac{3}{8}$  inch; 5 by  $\frac{1}{2}$  by  $\frac{1}{2}$  inch. These are packed in small wooden boxes, which are shipped in large crates or cases. A tabulation of the crate sizes and weights follows:

TABLE 9.—*Packing of talc crayons.*

Size, inches.	Gross per box.	Boxes per case.	Gross per case.	Shipping weight per case (pounds).
5 by $\frac{1}{2}$ by $\frac{1}{4}$ .....	$\frac{1}{2}$	24	12	300
5 by $1\frac{1}{4}$ by $\frac{1}{8}$ .....	$\frac{1}{2}$	24	12	250
5 by $\frac{1}{2}$ by $\frac{1}{4}$ .....	1	24	24	250
5 by $\frac{1}{2}$ by $\frac{1}{8}$ .....	1	24	24	200
5 by $\frac{1}{2}$ by $\frac{3}{8}$ .....	$\frac{1}{2}$	24	12	350
5 by $\frac{1}{2}$ by $\frac{1}{2}$ .....	1	24	24	145

The trade prefers a hard, tough pencil to a soft one, because the point wears less easily.

Talc pencils made up during the winter months and shipped without much drying were soft and broke easily. Tests showed that thorough drying and seasoning increase the durability. Possibly a slow baking or drying by artificial heat might improve stock not otherwise suitable for cutting.

## AMERICAN MINERAL CO., JOHNSON, VT.

The American Mineral Co. has a mill beside the tracks of the St. Johnsbury & Lake Champlain Railroad, near Johnson, Lamoille County, Vt. The main source of talc for this mill is a mine about 4 miles distant. A small tonnage, however, is taken from a deposit now nearly exhausted, near the mill, when weather conditions make difficult haulage by wagon from the main deposit. This deposit may possibly be reopened in the future, as the talc and not the grit was removed in the early mining, and a test pit from the surface, beyond the limits of the old workings, has encountered good talc. Development of a large body here would practically eliminate the present cost of haulage.

The main ore body is a typical lens striking roughly northeast and dipping west  $55^\circ$  to  $90^\circ$ . Outcrops of talc can be followed for over half a mile and seem to indicate a continuous body. Underground workings have proved up a block of solid talc and grit at least 1,500 feet long, 200 to 250 feet wide, and 130 feet deep. The total probable tonnage for this deposit is, according to published report, about 4,250,000 tons. This is the largest single deposit so far discovered in Vermont. The lens is bounded by walls of serpentine. Veins of pure white talc from 1 to 30 feet wide (average about 6 feet) line the walls, and the core is the typical grit. Both grit and talc are of exceptionally good quality and color.

## MINING METHOD.

The deposit was opened near the east wall by a small shaft at first, the vertical shaft changing in depth to conform to the changing dip of the wall. When the shaft, with its steam-driven equipment, deteriorated, it was decided to sink a new shaft having electrically driven machinery. This new installation is completed and the old shaft and plant will be abandoned.

The new shaft, sunk at a dip angle of  $68^\circ$  in the grit core, was cut 6 by 12 feet in the clear and divided into two compartments, a skip way and a ladder



UNDERGROUND VIEW SHOWING METHOD OF TUNNELING OF THE AMERICAN MINERAL CO., JOHNSON, VT.

Generated at University of Michigan on 2023-02-13 11:27 GMT / https://hdl.handle.net/2027/uiug.30112104112039  
Public Domain, Google-digitized / http://www.hathitrust.org/access\_use#pd-google



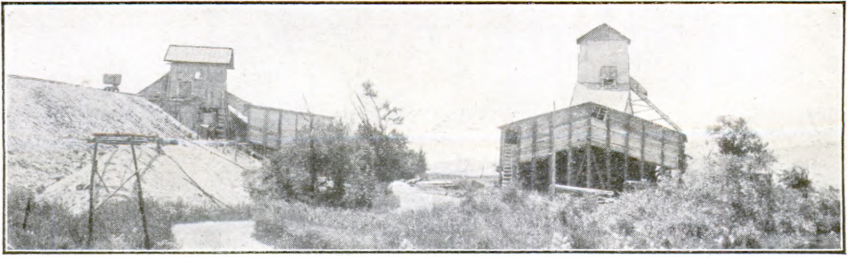

A. OLD AND NEW SHAFT HOUSES OF THE AMERICAN MINERAL CO., JOHNSON, VT. LARGE DOUBLE LOADING BIN IN RIGHT FOREGROUND.

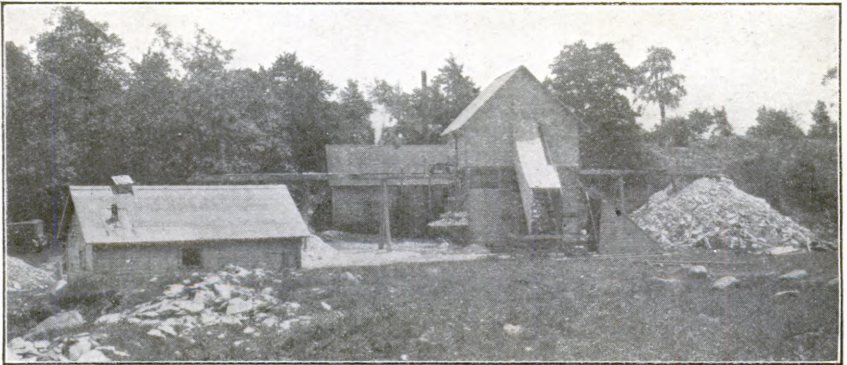

B. ROCK HOUSE OF THE W. H. LOOMIS TALC CORPORATION, GOUVERNEUR, N. Y.



C. OPEN CUT OF THE TALC PRODUCTS CO., GLENDON, N. C.

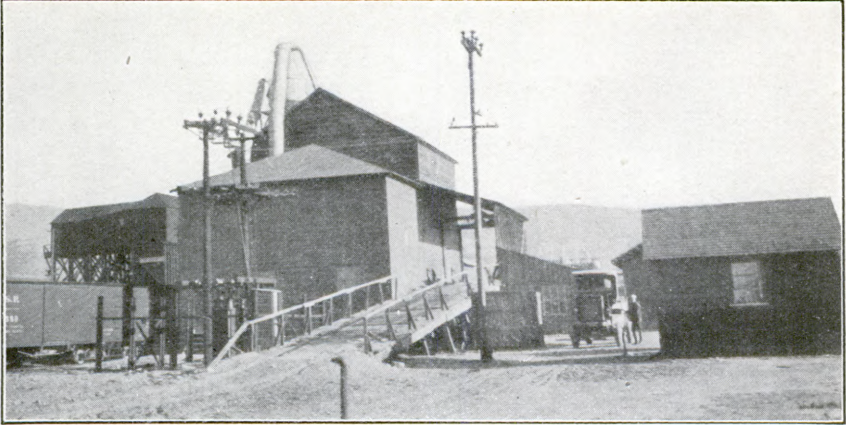

A. FRONT VIEW OF THE MILL OF THE INYO TALC CO., KEELER, CALIF.

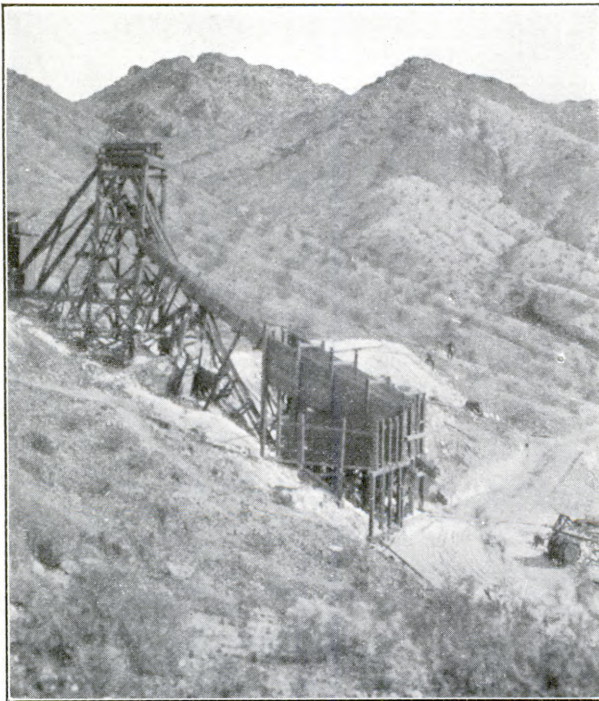

B. MAIN SHAFT OF THE PACIFIC COAST TALC CO., SILVER LAKE, CALIF.

THE LIBRARY  
OF THE  
UNIVERSITY OF ILLINOIS

Generated at University of Michigan on 2023-02-13 11:27 GMT / https://hdl.handle.net/2027/uiug.30112104112039  
Public Domain, Google-digitized / http://www.hathitrust.org/access\_use#pd-google

and pipe way. The skip way is equipped with a 2-ton, steel, 36-inch gage self-dumping skip. As the upper levels are largely abandoned, connection is made only with the 100-foot level. A 130-foot level is being cut to drain the old workings to the new shaft. From the shaft, drifts have been run in each direction along the east black wall; at several points crosscuts have been started toward the west or hanging wall, but the longest one—over 190 feet—had not reached the other wall in 1920. From the crosscuts drifts are cut, leaving longitudinal ribs 20 to 25 feet wide as pillars. The drifts and crosscuts are cut about 7 feet high and 20 to 25 feet wide. (See Pl. XIII.) No timbering of any kind is needed. Raises, 20 to 25 feet square, at an angle of about 45° with the horizontal, are put up at irregular and infrequent intervals. The pillars can be removed only when the mine is worked out. As noted in several other mines, practically all the ore is obtained from large development openings.

The ore is shot down on a layer of planks which keeps it dry and prevents mixture with impurities. Large blocks are usually shot down in raising, and much secondary blasting is necessary. From the headings the talc is trammed to the shaft in 24-inch gage, steel, rotary, end-dump cars holding about 1,800 pounds.

At the top of the shaft the skip dumps automatically into a chute leading to a large wooden bin (see Pl. XIV, A) which has storage capacity for 400 to 500 tons of rock. This bin has three gates on each side, so that the loading of trucks or wagons need never be delayed.

Drainage is not a serious problem, for the mine may be kept dry by pumping 60 to 80 gallons per minute for 8 hours. The new pump is a triplex Dean, 5 by 8 inches, 100 gallons a minute, driven by a direct-gear, 10-horsepower motor. Compressed air for drilling is furnished by a Laidlaw-Dunn-Gordon, 8½ by 9 inch single-stage compressor, belt driven from a 25-horsepower induction motor. The hoist is a Mead-Morrison, 2-ton, geared to 25-horsepower motor. Electricity—550-volt, 3-phase, 60-cycle, alternating current—is furnished by a hydroelectric plant at Morrisville, 8 miles from Johnson.

From the mine, the talc is hauled on contract by wagon or motor truck to the mill. A right of way was obtained for an aerial tramway connecting the mine and mill, but the project has been abandoned, at least temporarily.

#### MILLING.

At the mill, the talc is dumped in a large storage shed, from which it is loaded by hand onto a belt conveyor, which is made in sections so that the farthest end may be reached when the shed is nearly empty. This conveyor feeds the rock to a No. 4 Champion jaw crusher from which the product is re-crushed in a Sturtevant No. 1 rotary crusher. The crushed ore is then elevated to four crushed rock bins holding 2 to 4 tons apiece. Two bins feed two Sturtevant 30-inch vertical emery mills, and the other two feed Raymond No. 0 pulverizers or "cage mills." One emery mill and one pulverizer feed one 6-foot Raymond Cyclone air separator, and the other pair feed a similar separator. The finished products from the separators are bagged by a Richmond and a Huntley packer while the tailings go to separate Newago screens. The screen oversize is put through a third Newago screen from which the tailings are reground. The three Newago screens are 60-mesh and produce a coarse product which is elevated to a 120-ton bin and then bagged by hand. All machinery in the mill is electrically driven.

The capacity of the mill is 70 to 110 tons of fine talc plus 20 to 30 tons of the coarser product per 24-hour day, depending on the grade of rock received.

Since the above description was written the company has built a much larger mill utilizing more modern and efficient methods. Noteworthy features of this mill are large storage capacity for crushed rock and the bulk storage of finished talc in large, cylindrical, wood-stave silos, instead of storage in bags. The following partial description of this new mill is taken from Rock Products.<sup>23</sup>

"At the new mill the rock from the mine is dumped into a receiving hopper. \* \* \* This hopper discharges its contents through a reciprocating feeder into a jaw crusher, the output of which is taken by a continuous bucket elevator to a rotary crusher which prepares the rock for the pulverizers or mills.

"A conveyor and elevator carry the crushed talc either to a reserve storage bin which has a capacity of 2,700 tons or to a service bin for discharge by gravity into the mills.

"The reserve storage bin is built on the side of a hill to provide a sloping floor to facilitate reclaiming. By means of a reclaiming conveyor the reserve supply is taken to the service bin above the mills. \* \* \*

"The product of the mills is stored in seven overhead storage bins, five for the various grades of finely pulverized product, and two for tailings. The tailings are sized through screens before they are discharged into the bins. The rejects are returned to the service bin or to the reserve storage bin for regrinding. \* \* \*

"Bag packers under the storage bins for finished product are used for immediate loading in the cars, thus doing away with storing and rehandling. \* \* \*

"All machinery is motor-driven and arranged to eliminate hand labor as much as possible. In the selection and design of handling and pulverizing equipment, machinery was installed which would maintain the quality of the high-grade rock, both for color and slip."

## TALC MINING IN NEW YORK.

### IMPORTANCE AND DISTRIBUTION OF TALC IN NEW YORK.

Talc mining in the State of New York was first started about 1876, but noteworthy production did not start until 1880, when about 4,000 tons were shipped. In 1883 the production was about 6,000 tons, valued at \$75,000, or an average of \$12.50 per ton. From this date the production gradually increased to a peak of 93,236 tons, in 1916, valued at \$961,510, or about \$10.30 per ton. In 1918 the production declined to 71,167 tons, valued at \$902,100, or about \$12.70 per ton. For many years New York was the largest producer in the United States, but in 1917 and 1918 was surpassed by Vermont in tonnage, though not in value. In June, 1920, there were three companies producing talc in the Gouverneur district, St. Lawrence County, and one near Natural Bridge.

### MODE OF OCCURRENCE.

The geology of the talc deposits of New York has been described in detail by Smyth and Newland.<sup>24</sup>

<sup>23</sup> Rock Products, Talc mining and preparation: Vol. 24, April 23, 1921, pp. 19-23.

<sup>24</sup> Smyth, C. H., jr., New York State Mus. Rept. 47, 1894, pp. 491-515; also New York State Mus. Rept. 49-2, 1898, pp. 661-671. Newland, D. H., Bull. 322, Education Dept., New York State Mus., 1912, pp. 91-100.

The following brief description is by Newland.<sup>25</sup>

The Gouverneur talc district consists of a narrow belt lying to the southeast and east of that village, in the towns of Fowler and Edwards, in which the talc occurs in lenticular bodies arranged in series along the strike. The bodies dip uniformly toward the northwest at angles of from 30° to 60°, so that they are all worked by underground methods. The wall rocks are limestone and schist of Precambrian age, a part of the Adirondack crystalline formations. The fibrous talc is an alteration product of tremolite, which it resembles in physical development, but the scaly talc apparently is the result of deposition by underground waters. Altogether there are fully fifteen or twenty different deposits, some of which, however, are not profitable under present conditions, and others are being held in reserve. The number of operative mines in recent years has ranged from five to eight or nine. \* \* \*

A deposit of talc near Natural Bridge has been worked for the last four years and has supplied a considerable quantity of material which is sold in ground form. This deposit occurs in limestones, but in a separate area from the Gouverneur belt, and has a quite different character. The talc lacks any definite structure, except that it shows a granular appearance in places, and is associated with other hydrated silicates of the serpentine and chlorite groups. It appears to be a contact deposit lying near an intrusion of granite.

The fibrous talc of the Gouverneur district, as Newland has indicated, is wholly different in appearance and physical properties from that of the Natural Bridge deposit and from the talcs found in other parts of the country; it is an alteration product of tremolite and often shows the typical tremolite structure. Much of the material mined as talc is probably not talc but tremolite or a product of partial alteration, as much of it has a hardness of 2 to 3½ (pure talc is 1) and has little slip. The foliated talc found there more closely resembles other talcs, but it is usually harder and more micaceous. The hardness and fibrous structure make grinding and separation more difficult than in most other districts, but the present practice can probably be improved. For example, the separation of the crude rock into two or more grades, and the milling of each by separate processes would doubtless make more uniform products that would be better adapted to certain uses.

Economy in use of power has not been important in the Gouverneur district in the past, but steps are being taken to devise more economical methods of grinding. It seems probable that not only will power consumption be decreased, but better products will be obtained.

The ore reserves of the New York districts are probably large, although little accurate information is available. The talcose zone in the Gouverneur district is known to be more than a mile wide and numerous deposits have been opened, but prospecting has not been done on a scale adequate to block out large tonnages. Diamond drilling has been done by one company, but this served to locate veins

<sup>25</sup> Newland, D. H., *New York State Mus. Bull.* 178, 1915, pp. 78-80.

rather than to prove reserves. Diamond drilling for the latter purpose should prove of value.

The common method of mining is to sink a shaft on the vein, run levels or drifts in each direction from the shaft along the strike of the vein, and put up raises at intervals, leaving pillars between the raises. As a rule, little timbering is needed, except in fractured zones. Formerly most of the mines had only one opening to the surface, which is not in conformity with the present New York State law, and has caused some trouble.

#### DESCRIPTION OF INDIVIDUAL MINES AND PLANTS.

ST. LAWRENCE TALC CO. (CARBOLA CHEMICAL CO.), NATURAL BRIDGE, N. Y.

The mine and mill of the St. Lawrence Talc Co. or its successor, the Carbola Chemical Co., are about  $1\frac{1}{2}$  miles from Natural Bridge station, near the line between Lewis and Jefferson Counties. A railroad spur about one-half mile long connects the mill with the Carthage & Adirondack branch of the New York Central Railroad.

#### MINING.

The talc deposit seems to be a replacement, and is irregular in size and shape. Its strike is nearly north and south, but its dip can not be determined. Diller<sup>23</sup> says of this deposit: "The talc is associated with serpentine and limestone. Near by are highly crystalline, for the most part gneissoid rocks. The talc where opened to view lacks distinct schistosity or fibrous structure, and is rather massive. The sides of the talc body are very irregular \* \* \*. Although in general the talc is highly magnesian, some of it, as shown by laboratory tests with nitrate of cobalt, contains much alumina suggesting pyrophyllite." The deposit has been traced along its outcrop for a mile north from the shaft, and is a maximum of 90 feet in width in the present workings. Between the foot and hanging-walls proper, large "boulders" of limestone are often encountered. Usually these may be left as waste pillars but sometimes they must be shot out and either stowed away underground or hoisted to the surface. In addition to the limestone "boulders," nodules of quartz and limestone, and small particles of pyrite and graphite are common. A great many varieties of talc are encountered. No development work by drilling has been done and, on account of the great irregularity of the deposit, no close estimation of reserves may be made; but probably a large tonnage is still available.

The mine is opened by a 10 by 12 foot single-compartment inclined shaft dipping at an angle of  $57^\circ$  for the first 45 feet, and  $68^\circ$  below that point. Three levels have been opened, at vertical depths of 100, 147, and 202 feet, vertically below the surface. The first level, the only one developed extensively, has been opened for 600 feet, mainly north of the shaft. Drifts connected at frequent intervals by crosscuts have been cut along the foot and hanging walls, outlining the ore body. Both the ore and the walls are badly fractured in places, so that it is not always safe or advisable to follow the walls closely; and in places the drifts are in solid ore near the walls. The presence of limestone boulders and fractured zones in the ore governs the location of crosscuts and

<sup>23</sup> Diller, J. S., Talc and soapstone: U. S. Geol. Survey, Mineral Resources of the United States, 1912, pt. 2, p. 1158.

makes their location irregular. Little timber is needed in the mine except where the openings break into a fractured zone.

Although the mine has been worked for a number of years, little real mining has been done, most of the ore used in the mill coming from the network of development openings on the first level. No systematic method of mining has been devised, but the plan is to continue the present method of development to the limits of the ore body or until the workings get too far from the shaft. Then raises will be put up, beginning farthest from the shaft and taking advantage of the fractured zones. In places a single shot will start a run of broken ore that will last for days. Stopping will, therefore, be inexpensive, but probably admixture with waste will prevent recovery of all the ore.

Drainage has always been a serious problem, as the fractured condition of the ore and walls permits much surface water to get into the mine. The mine has been "drowned" several times in the past, but adequate pumping capacity is now available and there should be no further trouble from water. All pumps are electrically driven by 220-volt, 3-phase, 60-cycle alternating current. One pump is on the first level and four pumps with a large sump in the second level. In addition to the sump an old section of the mine has been sealed off with a concrete bulkhead provided with two 4-inch valves. In this way a large flow can be cut off for a week, in case of accident to the pumps. Each pump has a separate discharge line to the surface. The total pumping capacity installed, 1,350 gallons per minute, requires a total of 175 horsepower. The maximum flow of water has been 850 gallons per minute, but in the summer it is not over 250 to 275 gallons per minute. Every pump is run part of each day to keep it in working condition.

The drilling equipment in use consists of three compressed-air drills of the jack-hammer type, and three of the stoper type. The former are often used attached to a light column. The ore drills easily and shoots well, 35 per cent gelatin explosive being used.

The ore broken in development work is shoveled into 1-ton, 24-inch gauge, steel cars, trammed by hand to the shaft, dumped directly into a 1-ton, 30-inch gauge, steel, self-dumping skip and hoisted to the surface. At the surface the skip is hoisted up a wooden trestle 450 feet long, set at an inclination of about 18°, to the top of the rock house.

The surface equipment at the mine consists of a single-stage, 14 by 16 inch, 480 cubic feet air compressor belted to a 150-horsepower, 2,200-volt induction motor, and a machine shop. The present shop is fairly well equipped, but a new shop is being built, which will house a lathe, drill press, pipe machine, and drill sharpener. The hoist, which is located in the rock house at the mill, is a 3-ton hoist geared to a 50-horsepower, 220-volt, alternating-current motor.

#### MILLING.

At the top of the trestle connecting the mine and the mill are two dumping places at either of which a trip may be set to dump the skip automatically (see Fig. 8). In this way the crude storage bin may be filled to hold 400 tons without shoveling. At the bottom of the bin the ore is shoveled into a 12 by 28 inch jaw crusher, large blocks being sledged by hand. From here the progress of the ore through the mill may be followed on the flow sheet (Fig. 8). The tube mills are of the trunnion type, belt-driven by individual 150-horsepower, 2,200-volt, 3-phase, 60-cycle induction motors. These mills use 106 to 108 horsepower each when in motion under full load. Two mills are lined with siliceous and one with porcelain brick. Each uses a 12-ton charge of flint pebbles, about 300 pounds being added every three months to compensate for wear. A second set of three mills is held



in reserve. The mill capacity is about 2 tons per hour for the tube mills, and 1 ton per hour for the Raymond mill.

The finished talc is packed in 50-pound paper, 50-pound cloth, 100-pound cloth, or 200-pound burlap bags, and either trucked directly to cars or to a storage house. The storage of talc in paper bags has not been found desirable, because of breakage and waste in handling, and the erection of large bins for the storing of finished talc before bagging has been considered. In 1920, the storage capacity for bagged talc was about 2,500 tons. Most of the electric current

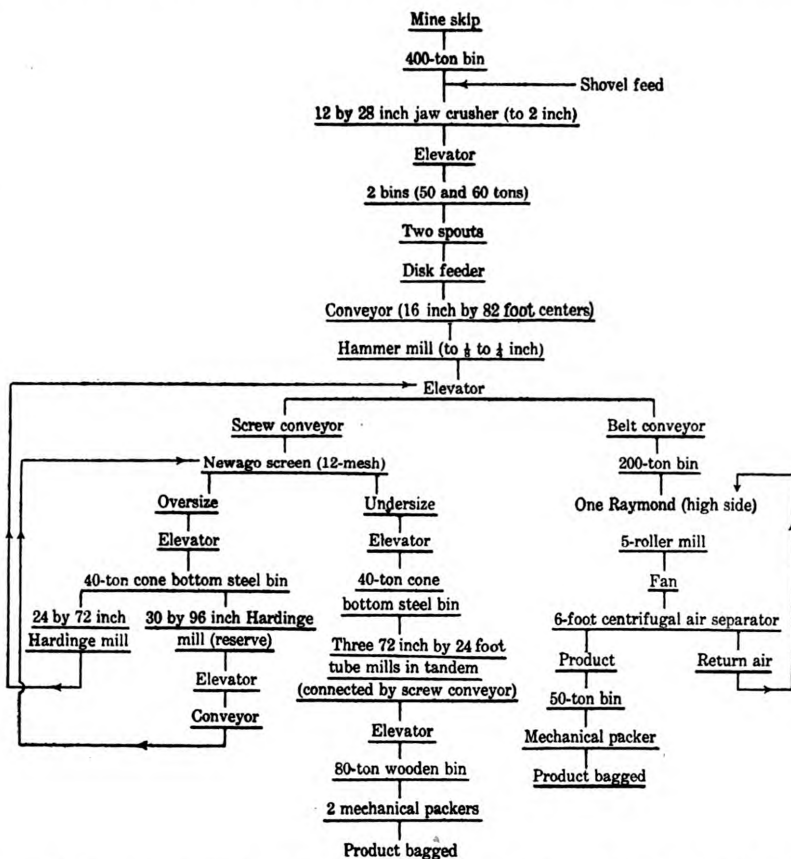

FIGURE 8.—Flow sheet of mill of St. Lawrence Talc Co., Natural Bridge, N. Y. Capacity, 72 tons per 24-hour day.

for the mine and mill is purchased from a local power company, but a hydro-electric plant owned by the company, synchronized with the public service power, is capable of furnishing about 150 kilowatts at high water.

#### UNIFORM FIBROUS TALC CO., TALCVILLE, N. Y.

The mine and the mill of the Uniform Fibrous Talc Co. are at Talcville, St. Lawrence County, N. Y., on the Edwards branch of the New York Central Railroad about 11 miles from Gouverneur. Production from the original mine began in 1911 and continued to increase until 1919, when cave-ins compelled a shutdown.

Immediately diamond drilling was started, which found several new veins a short distance west of the old workings. A new two-compartment vertical shaft, 7 by 9 feet, sunk to cut these veins, is down 140 feet. The first 40 feet of this shaft cut water-bearing strata, which were sealed off by cement grouting under pressure; then this section was lined with concrete.

In order to obtain immediate production, a small vein encountered in the shaft has been opened at the 120-foot level. A winze is now being sunk in this vein and the shaft will be deepened to at least 200 feet by raising from below, thus enabling production to be continued while the shaft is being deepened. From the bottom of the shaft, crosscuts will be driven not only to develop the new veins but also to recover the remaining talc in the old mine.

At the time of inspection (June, 1920) the new mine was not extensively developed and the method of mining had not been determined.

Ore from the mine is hoisted to the surface in a 1-ton steel skip and thence over an inclined trestle across the railroad siding to the "rock house" in which is located the hoist. The hoist is geared to a 52-horsepower, 220-volt, 138-ampere, 3-phase, 60-cycle induction motor. In the power house close by is a 2-stage, 14 by 9 by 10 inch 200 to 250 cubic feet air compressor belted to a 50-horsepower, 220-volt, 124-ampere, 3-phase, 60-cycle induction motor. Air pressure maintained at the drills is about 80 pounds per square inch.

MILLING.

The ore skip is dumped automatically in a chute leading to a picking floor at the top of the rock house (see Fig. 9), where waste is sorted out and 102740°—23—8

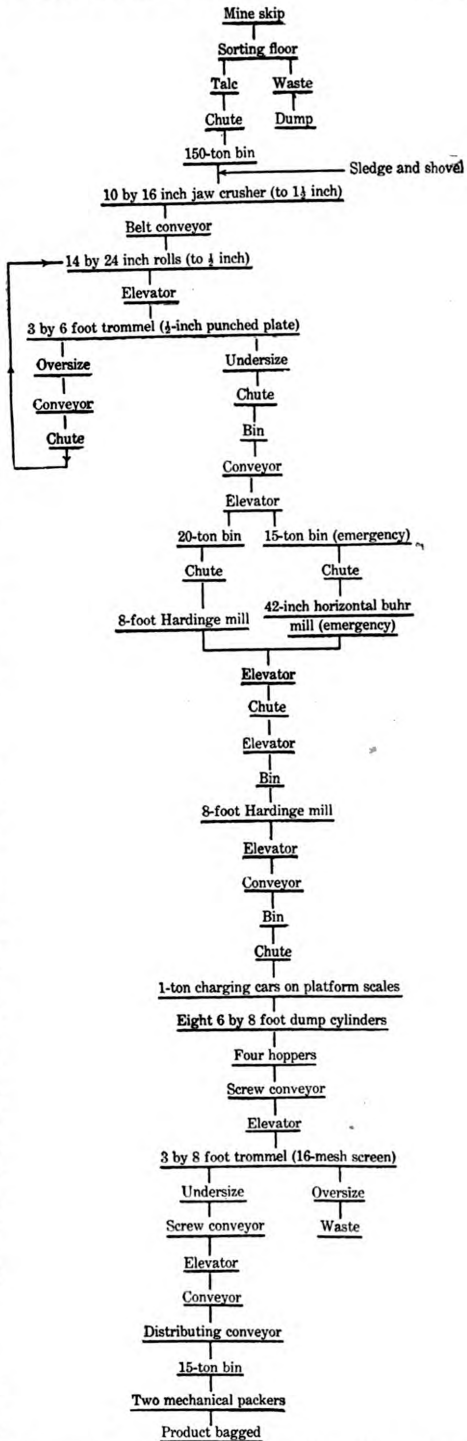

FIGURE 9.—Flow sheet of mill of the Uniform Fibrous Talc Co., Talcville, N. Y.

thrown into a chute landing to a waste car that is trammed to the waste dump. The ore is shoveled into a chute leading to a 150-ton rock bin, at the bottom of which the large lumps are broken down with sledges, and the ore is fed by shovel into a 10 by 16 inch jaw crusher.

This plant is perhaps typical of the talc plants using intermittent dump cylinders, or short pebble mills. The cylinders are of steel, 6 feet in diameter by 8 feet long, and are lined with porcelain brick. A charge (1 ton of talc and 3 tons of flint pebbles) is revolved at  $22\frac{1}{2}$  to 23 revolutions a minute for 4 to 7 hours. The finishing point is determined by visual inspection of the product. When the grinding is completed, the charging door is removed, a grating to hold back the pebbles is placed over the opening, and the mill is revolved until the talc all runs into a hopper beneath. At the bottom of each hopper, which serves two mills in parallel, is a screw conveyor that transfers the talc to an elevator, and thence to a 16-mesh revolving screen. This screen is intended to remove broken pebbles, sticks, and coarse impurities. It is estimated that 80 per cent of the finished product is packed in 50-pound paper bags.

A total of 500 horsepower of the equipment is installed at the mine and mill, of which the mill equipment calls for about 375 horsepower. The mill load is said to be about 350 horsepower. Of the total electric power used about 70 per cent is obtained from a hydroelectric plant owned by the company, on the Oswegatchie River, and the remainder is bought from a public service company.

#### INTERNATIONAL PULP CO., GOUVERNEUR, N. Y.

The mines and mills of the International Pulp Co. are in St. Lawrence County, N. Y., between Gouverneur and Talcville along the Edwards Branch of the New York Central Railroad. This old company has consolidated with it the mines formerly worked by the Union Talc Co. and the United States Talc Co. It is said that the company now owns or leases four mines and operates four mills. Of the mines the No. 2 $\frac{1}{2}$  and No. 4 at Talcville are the only ones on the railroad; of the four mills only two, Nos. 3 and 6, are on the railroad. This arrangement necessitates considerable hauling or double hauling for distances up to 7 miles by wagons in summer or sleds in winter. As the writer was allowed to visit only one mine, the Wight, which had not been in operation for some time, and only one mill, No. 6, the descriptions are incomplete. Some of the information given was obtained from publications, some from personal examination, and some from other sources.

#### MINING.

The mining method described here refers only to the Wight mine, but is said to be typical of the other mines of the company. The vein worked at the Wight mine is 6 to 25 feet thick and has an average dip of 35°. The mine has an inclined shaft sunk in the vein to a depth of 350 feet. At intervals of 50 feet vertically, drifts or levels are driven in the vein in each direction from the shaft. These drifts are cut about 20 feet high and 20 feet wide, or the width of the vein where it is less than 20 feet, and are arched at the top. Raises about 20 feet wide and the thickness of the vein are driven to the level above. Pillars about 30 feet wide are left between raises. Practically no timber is used in the mine. Ore from the raises rolls down the slope to the drift, where it is shoveled into cars, trammed by hand to the shaft, and dumped

directly into the skip. About 60 per cent of the ore is said to be removed in the first mining.

Drilling is done with compressed-air drills of the jack-hammer type used either alone or mounted on light columns or tripods. A 40 per cent nitrostarch explosive is used for blasting. Pumping, not an important item, is done by a steam pump on the 250-foot level.

At the surface the skip dumps the talc automatically to the floor of a rock house, where waste is separated by hand and loaded into cars that are trammed to a waste dump. The talc is similarly loaded into cars and trammed to a stock pile on the opposite side of the rock house. When the mine is running, the ore is hauled by wagon to the Columbia No. 3 and No. 5 mills.

MILLING.

Only the No. 6 mill, at Hailesboro, about two miles from Gouverneur, was examined. It is the largest and best equipped, having been built in 1909. Ore from the mines is brought into the mill in standard-gage railway cars, and unloaded either into a large concrete bin or into a chute which leads directly to the primary jaw crusher. Two crushers are in use, a 30 by 36 inch, which is the main crusher, and a 13 by 28 inch which is held in reserve. The progress of the ore through the mill is approximately as represented on the flow sheet. The tube mills used

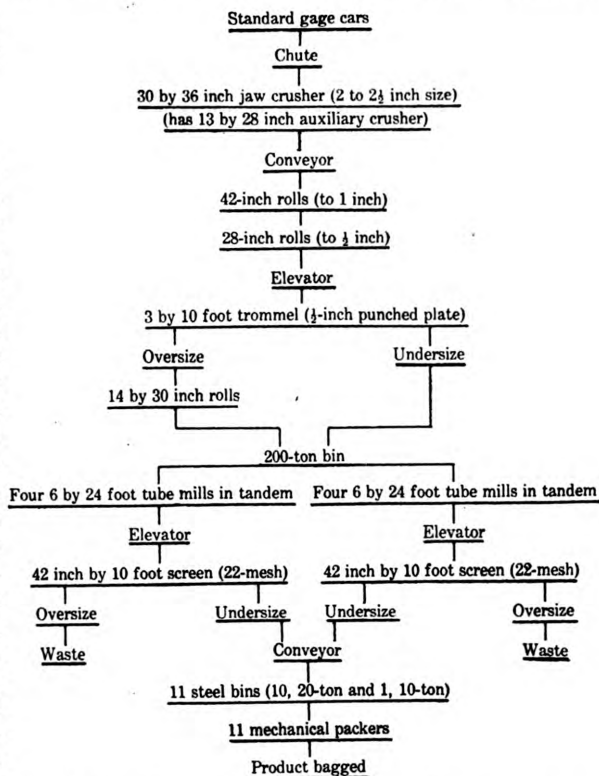

FIGURE 10.—Flow sheet of No. 6 mill of the International Pulp Co., Gouverneur, N. Y. Capacity, 100 tons per 24-hour day.

are set in two lines of four each in tandem, each line being driven by shafting as one unit. The discharge from each tube mill is elevated to the top of the building and conveyed by chutes to the next tube mill. The capacity of each line is about 2 tons an hour, making the total mill capacity about 4 tons an hour. Most of the mills are lined with siliceous flint, but some are lined with porcelain brick. Each mill requires about 150 horsepower, a total of 1,200 horsepower for the tube mills alone.

Large storage capacity for crude ore and for finished talc in bags is supplied. On account of loss by breakage in handling talc in paper bags, an effort is made to store most of the finished talc in burlap bags. For normal shipments 50-pound paper and 100 and 200 pound cloth bags are used.

Most of the power for this mill is supplied by the Oswegatchie River which flows by the mill. This water-power development furnishes about 1,500 horsepower to the mill at high water, and some additional electric power is used. Power is distributed to the main shafts of the mill by rope drive. The operation of the mill is said to be sometimes hampered by lack of water power.

The other mills of the company are said to differ from the No. 6 mainly in using intermittent-dump cylinders instead of continuous tube mills. The approximate flow sheet of No. 3 mill (Fig. 11) is said to be typical. The total production of the mills in June, 1920, probably averaged between 150 and 200 tons per 24-hour day, but their capacity was much larger.

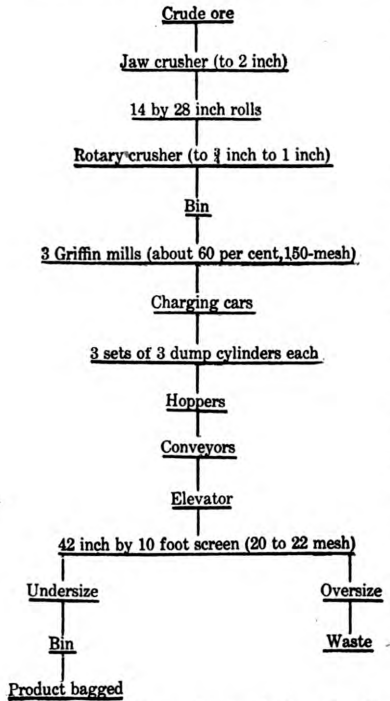

FIGURE 11.—Flow sheet of No. 3 mill of the International Pulp Co., Gouverneur, N. Y.

on the fourth level), of about 146 feet. A typical section from foot wall to hanging wall is: Talc 13 feet, waste 2 feet, talc 65 feet, waste 17 feet, talc 7 feet, waste 2 feet, talc 28 feet, waste 1 foot, talc 11 feet, no hanging wall; total 124 feet of talc and 22 feet of waste. The waste is so located that part may be left standing as pillars, part stowed underground, and a small amount hoisted.

Numerous varieties of talc are found, including practically all the varieties of fibrous, massive, and foliated talc found in the Gouverneur district. In parts of the mine the segregation of varieties is such as to suggest the possibility of mining several grades separately, or at least of making such a separation at the surface.

As the present management has devoted most of its time to development work on the fourth level, no method of mining has been adopted. The method

W. H. LOOMIS TALC CORPORATION,  
GOVERNEUR, N. Y.

The W. H. Loomis Talc Corporation began operations early in 1919 and a mill was completed early in 1921. The mill is on the Edwards branch of the New York Central Railroad, about 6 miles from Gouverneur. Ore comes from the Arnold mine, formerly operated by the Union Talc Co. and the International Pulp Co., in succession.

The Arnold mine is in the town of Fowler, about 6 miles from Gouverneur and 2 miles from both the present shipping point and the new mill. An inclined shaft in the vein, starting at a dip of  $55^\circ$  and gradually changing to about  $62\frac{1}{2}^\circ$ , has been sunk to a vertical depth of about 222 feet. Three levels are now open at vertical depth of about 125, 168, and 222 feet. The first or top level has been worked out and work is being done on the bottom level only. Drifts from 20 to over 400 feet long have been driven on each level. The vein or system of veins has a total width, as now exposed (neither the hanging nor the foot wall has been found

formerly followed by previous owners probably was similar to that at the Wight mine of the International Pulp Co.

Both the ore and the rock are strong and stand well, hence practically no timber is used. The shaft is 8½ by 9 feet in the clear and is timbered only with a few sets at the top. A ladderway, beside the skipway, has sollars 20 to 30 feet apart, vertically. Steel cars holding about 1¼ tons are dumped directly into a skip of the same capacity. Drainage is not a serious item; a steam pump, having a capacity of 100 gallons per minute, is run 1½ to 2 hours a day.

At the surface the skip automatically dumps the ore to the floor of a rock house (shown in Plate XIV, B, p. 99), where the waste is sorted out and trammed to a waste dump. The talc is either dropped through openings in the floor into bins with a total capacity of about 30 tons or is trammed to a stocking trestle and dumped. The bins are provided with chutes from which wagons are loaded. In the power house are a 15-horsepower belt-driven hoist, a 40-boiler horsepower locomotive-type boiler, and an 8 by 8 inch single-stage air compressor.

The ore at present is either hauled to the railroad for shipment as crude ore or to the mill, by wagons in summer and by sleds in winter.

At the time of the writer's visit the mill was under construction; now it is running on a commercial scale. The flow sheet (Fig. 12) is that on which the mill was built; only minor changes in it have been made since. The methods used are worthy of special notice, as they mark a radical departure from methods previously used in this district and for this type of material. Air separators remove finely ground material almost continuously, and the coarse product is sent back for regrinding. This method eliminates a large amount of the power wasted in using several tube mills in tandem and results in a finer and better-sized finished product. The horsepower consumed per ton of product is usually low for this type of material.

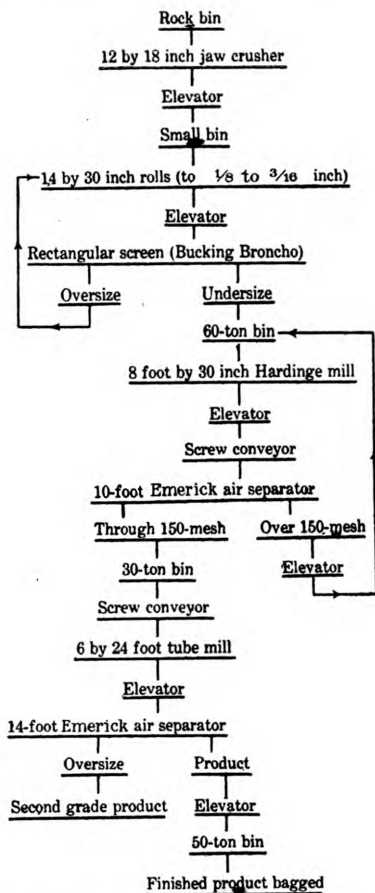

FIGURE 12.—Flow sheet of the W. H. Loomis Talc Corporation, Emeryville, N. Y. Theoretical capacity, 30 tons per 12-hour day.

TALC IN MASSACHUSETTS.

In the northwest corner of Massachusetts, close to the Vermont line, is an area of crystalline rocks containing valuable talc deposits that are practically on the strike of the Vermont talc deposits and

Generated at University of Michigan on 2023-02-13 11:27 GMT / https://hdl.handle.net/2027/uhug.30112104112039 Public Domain, Google-digitized / http://www.hathitrust.org/access\_use#pd-gd-google

probably are a continuation of them. Two producing talc mines have been opened here, that of the Massachusetts Talc Co., now inoperative, and that of the Foliated Talc Co. or its reported successor, the International Talc Co. As these two properties are adjacent, the surface and underground conditions are similar and only the latter property will be described.

#### FOLIATED TALC CO. (INTERNATIONAL TALC CO.), ROWE, MASS.

The mine of the Foliated Talc Co. is in Rowe Township, 4 miles from Zoar station, on the Fitchburg Division of the Boston & Maine Railroad and 2 miles south of the Vermont State line. The talc vein strikes about NE. and SW. and dips about 65° SE.; it is 55 to 65 feet thick, with no core of rock, between a hanging wall of chlorite schist and a footwall of fine-grained hornblende schist. The talc ranges from foliated to massive and from white, through greenish gray, to dark gray. The outcrop has been traced for about 2 miles on the property, but this length has not been definitely proved by drilling or underground development. An unusual feature of the deposit is the presence of emery in parts of the hanging wall. C. H. Hitchcock, according to an unpublished report, found a bed of emery 2 feet thick. He correlates this occurrence with that of the well-known emery deposit at Chester, Mass.

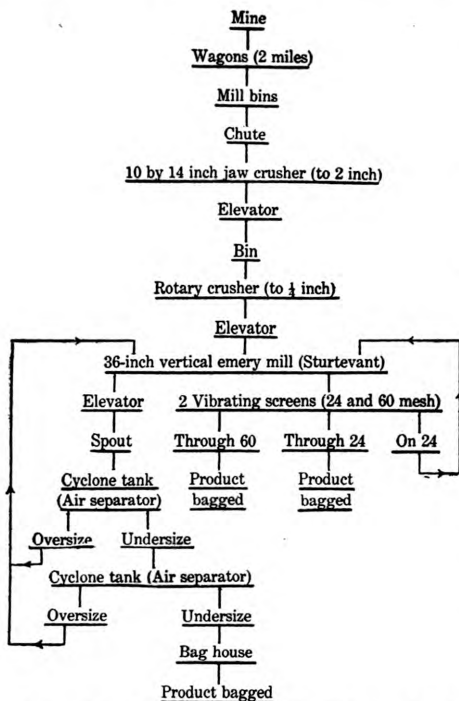

FIGURE 13.—Flow sheet of mill of Foliated Talc Co., Rowe, Mass. Capacity, 12 to 15 tons per 10-hour day.

The shaft drafts are turned off in each direction along the strike and within the talc body. The lower 40 feet of the shaft is used as a sump. At frequent but irregular intervals along both sides of the drift stopes are started and carried upward in a series of benches, leaving pillars for support where necessary. No timber is used. A main track runs down the center of each drift and spurs are laid to the foot of each stope. Talc in cars, trammed by hand along the levels, is dumped into skips at the shaft and hoisted to the surface. The mine equipment consists of a steam pump at the second level, and an air compressor, hoist, and boiler at the surface.

#### MINING METHOD.

An inclined shaft has been sunk in the vein at a dip of 65° to a depth of 240 feet, measured on the incline. At 100 feet and 200 feet below the collar of the

## MILLING.

The mill is in the village of Rowe, about 2 miles by road from the mine. At present the talc is transported from mine to mill by wagon, but an aerial tramway is under consideration. The mill has a capacity of 12 to 15 tons per 10-hour day, but increased capacity is planned. At present the crude rock is first crushed in a Blake-type jaw crusher and then in a Morse rotary crusher and a Sturtevant rotary grinder. (See Fig. 13.) The final grinding is done in a Sturtevant pulverizer equipped with the Sturtevant system of air separation. At present four grades are commonly made: Flour talc or dust from the Sturtevant system; through 180-mesh, used as paper filler; through 50 on 120 mesh; and through 80 on 200 mesh, used in the roofing and other industries. Most of the ground talc is grayish white or yellowish white, but it is claimed that the quality is improving in the deeper parts of the mine. The ground talc is sacked and hauled to the station at Zoar by wagon, but it is planned to use a motor truck.

## POWER.

The mill is driven by a 250-horsepower Leffel twin-turbine water wheel. Water power is abundant during the whole year, being supplied by a brook feeding a large natural reservoir, which in turn feeds a smaller artificial reservoir. From this a 30-inch steel flume carries the water 1,600 feet, with a 127-foot head, to the water wheel at the mill. Electric power may be easily obtained from a large commercial power company whose line passes close by the mill. The writer is indebted to H. C. Baker, Rowe, Mass., for much of the information regarding the mines contained in this report.

**HIGH-GRADE TALC AND THE CALIFORNIA TALC INDUSTRY.****HIGH-GRADE TALC DEFINED.**

High-grade prepared talc may be divided into two classes according to the use: (1) Massive talc, used for lava gas-burner tips and electrical insulation, pencils, and tailors' chalk; and (2) ground talc used for toilet powder. Talc of the first class, suitable for lava, is not common in the United States, and has been mined on a commercial scale in only a few localities, mainly at Hewitts, Swain County, N. C., in Hartford County, Md., and near Talledega, Ala. This phase of the subject has been well covered by Diller, Fairchild, and Larsen.<sup>27</sup> Talc that may be cut into crayons, tailors' chalk, etc., is more widely distributed, and has been produced in North Carolina, Georgia, Virginia, Vermont, and California.

The production of high-grade, white talc suitable for the manufacture of toilet powder is a problem that requires considerable attention. Until the last few years most of the toilet-grade talc consumed in the United States was imported mainly from Canada, Italy, and France. A small, irregular production of white talc was

<sup>27</sup> Diller, J. S., Fairchild, J. G., and Larsen, E. S., *Econ. Geol.*, vol. 15, December, 1920, pp. 665-673.



obtained from North Carolina, Georgia, and Virginia, but fluctuated so greatly in quality that it was not largely used by manufacturers of high-grade toilet powders. Gradually prejudice against all domestic talc grew up in the toilet trade, and has been fostered by persons interested in the sale of imported talc.

#### DOMESTIC PRODUCTION AND IMPORTS.

Little interest was shown in deposits of high-grade talc in California until 1911 and 1912. Then interest died down again until the World War curtailed imports from overseas in 1917, and caused a remarkable increase in production from 630 tons in 1916 to 4,152 tons in 1917. In 1918, California stood third in the list of talc-producing States, with eight going mines and a total production of 10,364 tons, valued at \$170,775. This great stimulus to production led to the development of several exceptionally high-grade deposits and the erection of modern and efficient mills. Production was at a high level until the latter part of 1920. During 1920, however, imports of talc from Italy and France increased greatly, and those from Canada were the largest in history. The total imports of talc in 1920 were 21,729 tons, valued at \$442,732, a greater total than any preceding year. Meanwhile ocean freight rates decreased and trans-continental railroad freight rates greatly increased. Thus California producers are now faced with high costs of production, high freight rates, and increased foreign competition encouraged by the lower labor and freight costs abroad and by a very favorable condition of foreign exchange.

#### ESSENTIAL QUALITIES.

Aside from import duties the chief point to be considered in meeting foreign competition is quality. A difference of a few dollars in the price of a ton of talc is of little importance to the manufacturer of toilet powder, for the cost of the talc is an unimportant item in the cost of a package of finished powder. Definite, standard, physical tests for quality of talc are lacking, so comparisons of quality are largely governed by personal opinion and prejudice. Some of the characteristics demanded of talc for toilet powder are as follows: Pure white color, good slip, freedom from grit, fine-grain size, and freedom from lime. Consumers differ as to the necessity for insisting on all of these qualities; some consider a good slip very necessary, whereas others consider it unimportant or even objectionable; some consider lime a harmful impurity, but others do not object to it if finely ground. It is probable that lime is not as objectionable an impurity as claimed, for some Canadian talcs, comparatively high in lime, are imported and used in large quantities in the United States.

Another objection raised to some domestic talcs is that they tend to "ball up" or collect in small clots when poured or shaken from a can. This property is common to most very finely ground materials and is, in a way, an index to fineness. If this property is objectionable, it can be easily remedied, with a decrease in cost of production, by coarser grinding; but to most consumers extreme fineness is a virtue and not an objection. In the essential qualities—pure white color, freedom from grit, and fine-grain size—it is well established that the best California talcs equal or surpass the best imported talcs. In the debatable qualities of slip and freedom from lime, some of the best California talcs equal some of the best imported talcs, and in other cases excel other imported talcs. Some of the largest consumers of toilet-grade talc have expressed complete satisfaction with high-grade California talcs and have used them regularly in preference to the Italian material.

It can not be truthfully said, then, that the United States produces no talcs equal in quality to the imported. Unfortunately, many domestic consumers have been so thoroughly imbued with the alleged superiority of imported talcs that domestic talcs have not been given a fair chance. It is even reported that unscrupulous dealers have relabeled domestic talc and sold it as Italian, with perfect satisfaction to the consumers. Such dishonest trade practices are probably not common, but they refute the erroneous statements regarding the quality of domestic talc. In order to make the domestic product better known, a brief description of the California talc industry seems advisable.

#### CALIFORNIA TALC INDUSTRY.<sup>28</sup>

The most important talc-producing districts in California have been in San Bernardino and Inyo Counties, with the former leading, but some shipments have been made from Eldorado, Los Angeles, Tulare, and Amador Counties, and there are deposits in several other counties. In Inyo County the deposits are in the vicinity of Owens Lake, and the chief producer in this district is the Inyo Talc Co., at Keeler. In San Bernardino County the principal talc deposits lie along the Tonopah & Tidewater Railroad, between the stations of Shoshone and Silver Lake, for about 18 miles. The most important producing companies there are the Pacific Coast Talc Co., the Pacific Minerals & Chemical Co., and the Talc Products Co.

The leading talc deposits in California are some distance from the railroad and are handicapped by cost of haulage. In addition the mines and mills are a distance from the chief markets, thereby being affected by high freight rates. The present freight rates on

<sup>28</sup> Much of the information in this section is taken from an unpublished report by B. O. Pickard, mining engineer, U. S. Bureau of Mines experiment station, Berkeley, Calif.

talc from the Pacific coast to New York and Chicago are about \$20 and \$17 per ton, respectively. From most of the mines in the Owens Lake and Death Valley districts to the grinding plants at Los Angeles the freight rate on talc varies from \$3 to \$5 per ton.

In California the problems of talc mining and milling differ from those in the eastern districts. Most of the deposits occur in arid regions, there are no pumping problems, and it is not necessary to dry the ore before grinding. The deposits are generally small, shallow lenses rather than extended veins. As they yield high-grade talc rather than an industrial grade, mining is on a small scale, intermittent, and irregular. All drilling and tramming is done by hand. The mines are so far from railroads that costly, long-distance haulage by motor trucks or tractors is necessary. In the best deposits the talc occurs practically pure, so that very little hand-sorting for the removal of limestone, silica, and other impurities is necessary. The local demand for industrial-grade talc is small and the markets for high-grade talc are in the East. Unusual mining conditions, unfavorable location of deposits, and the high standards of quality for the finished product result in higher costs of mining, milling, and transportation than are general in the East in the production of industrial-grade talcs.

THE INYO TALC CO., KEELER, CALIF.

The Inyo Talc Co. owns properties in the vicinity of Keeler, Inyo County, on the Southern Pacific Railroad. The grinding mill shown in Plate XV, A, p. 98, is at Keeler, but the mine is 18 miles distant. Keeler is the terminal of the Southern Pacific narrow-gage line connecting at Owenyo with the standard gage. This company owns three deposits of talc, two of which are being operated and the third is being prospected. The talc occurs in dolomite as lenses of irregular size and shape; it is massive and granular, rather than fibrous or foliated, and when crude ranges in color from a light, slate gray with a greenish tint to a pale sea green. The ground product is a clear, brilliant white; it contains practically no free silica and averages less than 1 per cent of lime (CaO).

Tunnels (adits) are driven in the dolomite hanging wall; they are 4 by 6 feet in cross section and are timbered with sets. Crosscuts are driven to the ore body and drifts run along its center.

The ore is broken down by a system of block caving and is removed from the mine by hand tramming in small end-dump cars. At the surface the ore is dumped into storage bins, from which motor trucks haul it to the mill. All drilling is by hand and no timber is used in the stopes.

At the mill the ore is dumped into 200-ton storage bins, from which it is shoveled by hand into a Wheeling forced-feed, 6 by 12 inch jaw crusher. From the crusher feed are removed large, sound blocks of talc suitable for sawing; these are shaped into cores for heating elements of electrical-heating devices, such as coffee percolators. The waste from the saws is returned to the crusher and the crushed rock is ground, as shown in the flow sheet.

Two grades of ground talc are made, the regular Raymond mill product and the product from the tubular dust collector. These are sold respectively as Sierra Snow (99.6 per cent through 200-mesh) and Sierra Cloud (99.9 per cent through 300-mesh). The relative proportion of the minus 300-mesh

product obtainable in this method of grinding depends on the nature of the talc and the adjustment of the machine. When a Raymond mill or any other fine-grinding machine is adjusted to give an increasingly fine product the capacity is more than proportionately reduced. Fortunately this talc is unusually well suited to this type of grinder, and an average of nearly 15 per cent of minus 300-mesh product is maintained. A greater proportion could be obtained, but at an unwarranted increase in cost.

The mill machinery is all driven by electric motors, a total of 95 horsepower being used. Special care is taken in all stages of the milling process to insure highest quality and uniform grade.

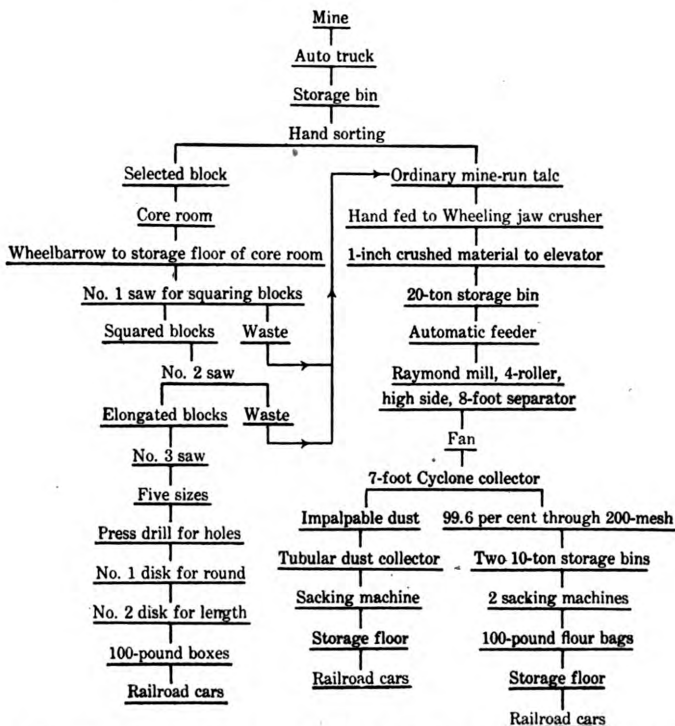

FIGURE 14.—Flow sheet of mill of Inyo Talc Co., Keeler, Calif. Capacity, 30 to 40 tons an 8-hour day.

THE PACIFIC COAST TALCO CO., SILVER LAKE, CALIF.

The Pacific Coast Talc Co. has a talc mine near Silver Lake, San Bernardino County, and a grinding mill at Los Angeles. The mine is about 8 miles from the railroad and the crude ore is hauled by a 5-ton motor truck to the nearest station, Riggs, on the Tonopah & Tidewater Railroad. The crude talc is a pure, silvery white and has a foliated texture, somewhat resembling that from the Geo. H. Gillespie mine at Madoc, Ontario, Canada. The ground product is a clear, silver white, with a very good slip, no grit, and very little lime, a typical analysis showing 0.31 per cent calcium oxide. The ore occurs chiefly as irregular shoots, 4 to 7 feet thick, dipping at an angle of about 57°, in ferromagnesian schists. The crude talc is very pure and practically no sorting is necessary.

Generated at University of Michigan on 2023-02-13 11:27 GMT / https://hdl.handle.net/2027/ulug.30112104112039  
 Public Domain, Google-digitized / http://www.hathitrust.org/access\_use#pd-google

Various parts of the deposit are opened by three shafts, but only one of these is being worked; it (Pl. XV, B, p. 98) is sunk in the vein on an incline of about 60° to about 120 feet. At the 70-foot level a main drift has been driven in the ore, shaft pillars 50 feet wide being left. From the main drift raises are put up and widened out into stopes. The two stopes now working are 100 feet wide and 60 feet long, respectively. The ore is soft; it is drilled by hand, either with augers or hand drills, shot down with 40 per cent dynamite, and allowed to accumulate in the stope so that the roof is always accessible. Excess ore is drawn off through chutes into one-half-ton, end-dump mine cars. This mining method is similar to that used at Madoc, Ontario, and is known as shrinkage stoping. No timbering is needed in the main drifts, but 8-inch by

8-inch props or stulls are used in the stopes. All the waste that must be removed is stored underground.

From the chutes the talc is trammed by hand to the shaft and dumped into one-half-ton buckets running on skids in the shaft. The buckets are hoisted by a 16-horsepower gasoline hoist and dumped automatically into a 30-ton bin. Natural ventilation in the mine is poor, and air is furnished at the working faces by a small ventilating fan. As the mine is dry, no pumping is necessary. From the bin at the shaft the ore is drawn off into a 5-ton motor truck and is hauled 5 miles to Riggs, the nearest shipping point, where it goes in box cars to the grinding mill at Los Angeles.

At the mill the ore is unloaded by hand into wheelbarrows, carried into the mill, and dumped into a storage bin, from which it is shoveled into an 8 by 15 inch Wheeling forced-feed jaw crusher. The progress of the talc through the mill may be followed from the flow sheet (see Fig. 15). The mill is driven by alternating-

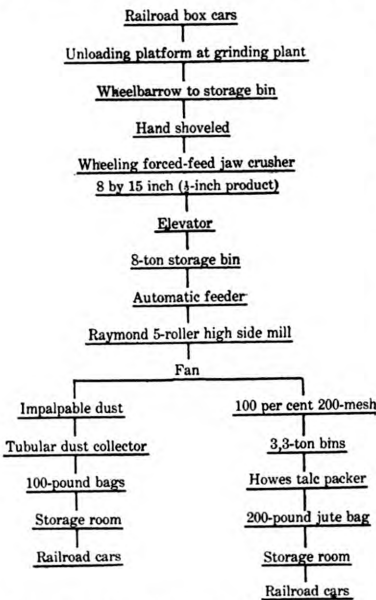

FIGURE 15.—Flow sheet of mill of Pacific Coast Talc Co. Capacity, 17½ tons per 10-hour day.

current, 400-volt, 50-cycle, 5-ampere is used.

The finished product is very high grade; it is extremely fine, has no grit, an excellent color, a very good slip, and adheres well to the skin. A typical analysis shows 0.31 per cent lime (CaO) and 0.28 per cent iron oxide.

#### OTHER COMPANIES.

Other California companies that have been more or less active producers in recent years are noted below.

The Talc Products Co. mine is 1¼ miles from Riggs siding on the Tonopah & Tidewater Railroad, south of Death Valley Junction. The mill at Los Angeles grinds talc only part of the time and has capacity of about six tons an eight-hour day.

The Pacific Minerals & Chemical Co. mine is 6 miles from Acme on the Tonopah & Tidewater Railroad, south of Death Valley Junction. The mill is at Glendale and has a capacity of 10 to 15 tons a nine-hour day. Fine grinding

is done with two Fuller mills each equipped with a special vacuum air separator. The product is pure white and more than 98 per cent will pass through a 200-mesh screen.

In addition, several other companies have mined talc in a small way, but little definite information on them could be obtained.

Early in 1921, owing of foreign competition, high freight rates to eastern market, high production costs, and general business depression, there was little productive activity in the California talc district.

**THE SOUTHERN TALC INDUSTRY.**

The talc industry in the South is confined to North Carolina, Georgia, Tennessee, Virginia, and Alabama. Tennessee is not a producer of crude talc, but there are several talc-grinding or manufacturing plants in Chattanooga. Most of the mines and mills are small, and the output of ground talc is not a large factor in national production. Much of the talc, however, is high grade, and the deposits are important potentially as a possible source of toilet-grade talc. Most of the material now mined is of the massive or compact variety and is sawed into pencils, crayons, or tailor's chalk. A large proportion of all the talc crayons used in the United States is produced in the South.

Two varieties of commercial talc are mined, talc proper or steatite, and pyrophyllite, the hydrous aluminum silicate, which can be used interchangeably for most purposes and are both known to the trade as talc. The only commercial deposits of pyrophyllite talc known in the United States are in or near Moore County, N. C. Commercial deposits of steatite talc occur in Buncombe, Madison, Jackson, Swain, and Cherokee Counties, N. C., and in Murray County, Ga. Table 10 lists companies operating mines or mills in North Carolina, Georgia, and Tennessee. Several of these companies have additional properties that are now idle or that are being developed preparatory to production. Other companies have mines or mills that are idle but may again become producers.

Ground soapstone is produced by the Blue Ridge Talc Co. at Henry, Va., and by the Bull Run Talc & Soapstone Co., Clifton Station, Va.

TABLE 10.—*Companies operating mines or mills in North Carolina, Georgia, and Tennessee.*

Company.	Mine.	Pencil mill.	Grinding mill.	Main office.
Talc Products Co...	Glendon, N. C....	Glendon, N. C....	Glendon, N. C....	120 Broadway, New York City.
Standard Mineral Co.	Hemp, N. C.....	Hemp, N. C.....	Charlotte, N. C....	Woolworth Building, New York City.
Biltmore Talc Co...	Marble, N. C.....	Biltmore, N. C....	Biltmore, N. C....	Asheville, N. C.
Georgia Talc Co....	Candler, N. C....	Candler, N. C....	Candler, N. C....	Do.
	Marshall, N. C....	Marshall, N. C....	.....do.....	Do.
	Chatsworth, Ga...	Chatsworth, Ga...	Chatsworth, Ga...	Do.
Chattanooga Talc Co.	.....do.....	.....do.....	.....do.....	Volunteer Building, Chattanooga, Tenn.
	.....do.....	.....do.....	Chattanooga, Tenn.	Do.

Generated at University of Michigan on 2023-02-13 11:27 GMT / https://hdl.handle.net/2027/duig.30112104112039  
Public Domain, Google-digitized / http://www.hathitrust.org/access\_use#pd-google

The talc mining and milling operations of the South are on such a small scale that economy of operation has not been possible. Except the pyrophyllite deposit at Glendon and Hemp, the veins are narrow, usually less than 15 feet; 6 to 8 foot veins are common. Many of the deposits are far from the railroad, which is accessible only by poor mountain roads; one mine now being worked for pencil stock is 18 miles from the nearest railroad siding. Lack of capital to build tram roads, cableways, and mills has prevented economical development. At the mines farthest from the railroads no attempt has been made to save anything but pencil stock, and the pencils are sawed at the mines. All material not suitable for sawing and all the saw waste are thrown away, with the result that probably not over 20 per cent of the talc removed at such mines is marketed. In spite of this waste, a fair profit has been made on crayons and pencils, but talc mining in the South has not been profitable. It has been estimated that the market demand for all grades of talc crayons is 200,000 to 225,000 gross a year, which would mean, at most, a yearly production of less than 1,000 tons of talc in the form of pencils. The crayon business alone, therefore, can not yield a profit that will justify large operations. The present pencil-sawing capacity of the Southern mills is more than adequate to supply the entire domestic market.

The quality and extent of some of the deposits are such as to justify the erection of modern, well-equipped grinding plants of moderate size; mills well situated with respect to transportation facilities and the best deposits would justify expenditures large enough to insure economical mining and transportation.

As the mines and mills are small, the writer did not visit all the producing mines and mills, but a general idea of the operations may be obtained from the descriptions that follow.

#### DESCRIPTION OF INDIVIDUAL MINES AND PLANTS.

##### TALC PRODUCTS CO., GLENDON, N. C.

The pyrophyllite deposits from which this company obtains its ore extend for miles across the north central part of Moore County, and the south central part of Chatham County. The rocks strike about 55° N. to 60° E., and the dip varies from 40° to 70° N. W. In places the deposits are 500 feet wide, but pinches and the presence of impurities have reduced the mineable width to 50 feet or less even in the largest openings. The geology and general relationships of this formation have been well described by Pratt.<sup>29</sup>

Prospecting has been done at various places along the outcrop, but at only one place has much ore been removed. About 2 miles north of Glendon station on the Norfolk & Southern Railroad is an open cut (Pl. XIV, C) along the center of the deposit 50 to 75 feet wide, several hundred feet long, and 40

<sup>29</sup> Pratt, J. H., Talc and pyrophyllite deposits in North Carolina: North Carolina Geol. Survey Econ. Paper No. 3, 1900, 29 pp.

to 50 feet deep. From the west end of the cut tunnels along the strike have proved the ore continues for several hundred feet. Talc has been mined here for many years, but the production has never been large. Impurities in the form of small quartz seams, and small particles of chlorite, hematite, and magnetite occur irregularly in certain parts of the vein, necessitating careful sorting of the crude ore and the discarding of large quantities of material on waste dumps. Most of the talc on the dumps is of good color, and by the use of modern grinding and separating machinery, most of the talc could probably be recovered.

As the present mill needs can be supplied with less than 10 tons of crude talc a day, mining is on a very small scale and few men are employed, but a new mill is being built, and it is planned to mine much more talc. The best parts of the talc vein as exposed in the cut are chosen, and holes are drilled by hand. Few holes are drilled at a time, and they are so placed as to remove as much talc as possible in the form of large, sound blocks. In shooting, 40 per cent standard Aetna powder is used. After a shot the rock is divided into pencil stock, grinding stock, and waste. The waste is taken in small steel cars to the waste dump, and the good rock is transferred in cars to a loading platform at the west entrance to the cut. From the loading platform the rock is hauled in wagons to the mill, about one-fourth mile distant.

A tunnel crosscutting the vein about 25 feet below the quarry floor on the north or hanging-wall side has been started. At this point the pyrophyllite seems to have a maximum thickness of 200 feet. The talc in the tunnel seems to be of better grade than that at the higher levels, and the plan is to reopen the deposit at a lower level rather than to continue along the strike. No information on the width of the deposit at greater depth is obtainable. Drainage from the present level is simple, the openings being on a hillside above water level. Although no considerable tonnage of ore has been actually developed, it seems probable that supplies can stock a moderate size mill for many years.

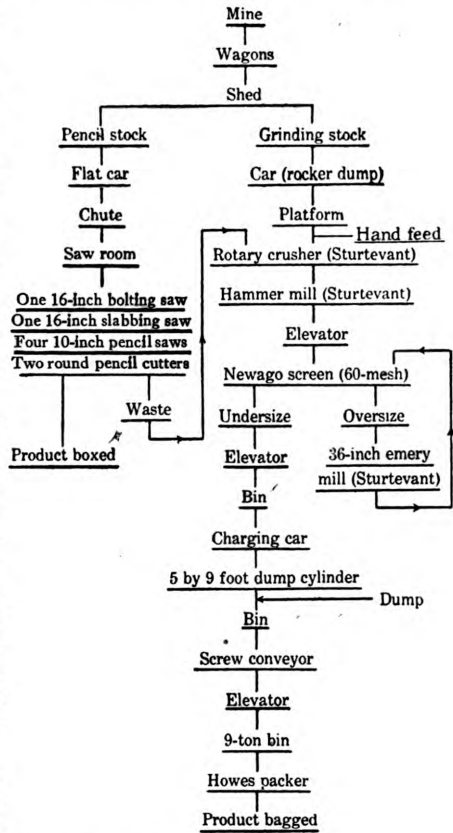

FIGURE 16.—Flow sheet of old mill of Talc Products Co., Glendon, N. C. Capacity, 7½ tons of ground talc per 24-hour day; 125 gross of pencils per 10-hour day.

MILLING.

The Talc Products Co. mill is about 2 miles from the Glendon station and one-fourth mile from the mine. Crude ore from the mine is unloaded in a



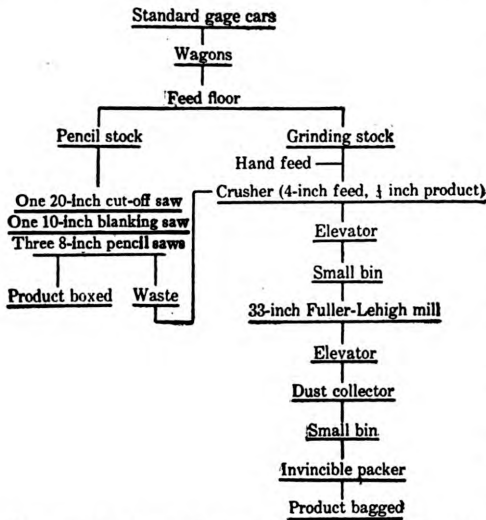

FIGURE 17.—Flow sheet of mill of Biltmore Talc Co., Biltmore, N. C. Capacity, 8 to 10 tons of ground talc per 24-hour day and 150 gross of pencils per 10-hour day.

shed near the entrance to the top floor of the mill. The progress of the talc through the mill is shown by the flow sheet. (Fig. 16.) The tube mill or dump cylinder used is 5 feet in diameter by 9 feet long, with a wood-block lining. A charge of 2,600 pounds of talc and 5,500 pounds of flint pebbles is revolved about four hours at 21 revolutions per minute. The resulting product averages 96 per cent through a 200-mesh screen. Finished talc in bags is hauled 2 miles to the station by wagon. Power for the mill is supplied by one 75-horsepower engine connected to two 60-horsepower boilers fired with wood.

Although the present mill is small, the extent of the deposit and the quality of the talc encourage larger production. Accordingly, a modern grinding plant of moderate size is planned beside a railroad siding at

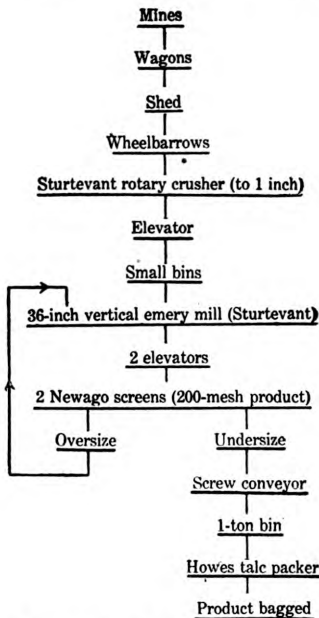

FIGURE 18.—Flow sheet of mill of Georgia Talc Co., Chatsworth, Ga. Capacity, 5 tons per 10-hour day.

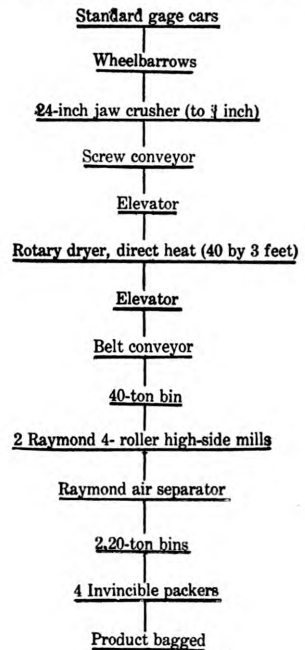

FIGURE 19.—Flow sheet of mill of Chattanooga Talc Co., Chattanooga, Tenn.

Glendon. A wet method of grinding and water classification by the Dorr system will be used. The new mill will have a capacity of 100 tons per

24-hour day and will produce a finely ground product practically free from grit. Utilization of much of the waste material on the dumps is contemplated. Compressed-air drills will be installed at the mines and a fleet of small motor trucks will be used to haul the crude ore to the mill.

THE BILTMORE TALC CO., BILTMORE, N. C.

The mines of the Biltmore Talc Co. are near Marble and Murphy, in Cherokee County; the mine near Marble was formerly worked by the Kilpatrick Development Co. The geological relations there and at Murphy are similar to those of the whole talc-bearing belt of western North Carolina.

The principal mine operated by this company is on the Valley River, 2 miles west of Marble, where a vein is opened by a vertical 75-foot shaft with drifts from the bottom along the vein, whose thickness ranges up to a maximum of 30 feet, between walls of marble and granite. Simple, overhand-stopping methods are used in mining. The walls do not stand well and careful timbering is necessary. As considerable water is encountered, pumping is continuous. The ore is loaded into standard-gage cars and shipped over the Southern Railroad about 114 miles to the company's mill at Biltmore, N. C.

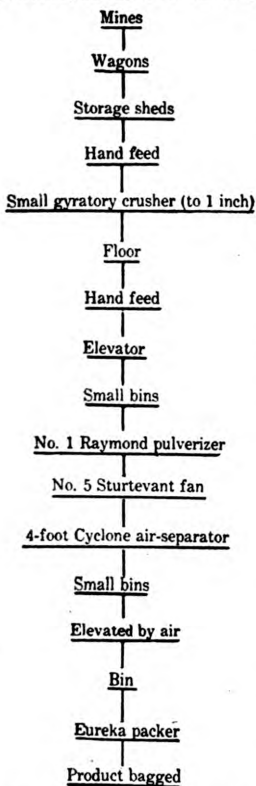

FIGURE 20.—Flow sheet of mill of Cohutta Talc Co., Chatsworth, Ga. Capacity, 4 to 5 tons per 10-hour day.

MILLING.

At the mill the ore is unloaded into wagons and hauled a few hundred feet to the mill, but the laying of a new railroad siding close to the mill is under consideration. The wagons discharge their load on the mill floor and the talc is sorted into pencil stock and grinding stock. The progress of the talc through the mill may be followed from the flow sheet. (Fig. 17.) Two grades of ground talc

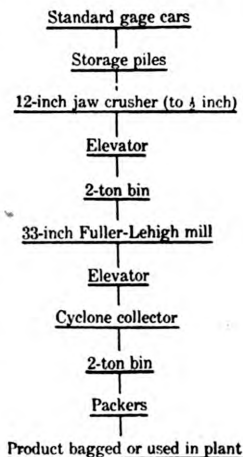

FIGURE 21.—Flow sheet of mill of D. M. Steward Co., Chattanooga, Tenn. Capacity, 10 to 15 tons per 10-hour day.

are made, differing in color only. The pencil mill makes all the standard sizes, some of which are divided according to hardness into two grades—metal-workers' crayons and school crayons. Some tailors' chalk is produced—though it has been made successfully from domestic talc in only one or two other mills.

Talc from this deposit is of exceptionally straight grain, has firm grain, and may be cut in thin, flexible strips three thirty-seconds inch thick by more than a foot long. Power for the grinding plant is supplied by one 50-horsepower and one 7½-horsepower motor; for the pencil saws, by one 30-horsepower motor. Electric current is obtained from a local power company.

## FLOW SHEETS OF OTHER MILLS.

The following flow sheets (Figs. 18, 19, 20, and 21) of talc mills are added for the sake of completeness, although detailed descriptions of the mines and mills are not available. The mills were examined by the author, but the mines were not visited or the information obtained was too incomplete to be of value.

**MINING AND MILLING AT MADOC, ONTARIO, CANADA.**

Although deposits of talc are known in many districts in Canada, at present active mining is reported only in Ontario. Talc production in Canada has increased steadily during the last 10 years, and can be followed approximately from imports into this country. Practically all of the talc produced in Canada comes from near Madoc, Hasting County, Ontario, where three companies, the George H. Gillespie & Co., of Madoc; Anglo-American Talc Co., of Madoc; and the Eldorado Mining & Milling Co., of Eldorado, are producing ground talc. Of these companies the George H. Gillespie Co. is probably the largest and ships the highest grade of talc. According to reports of the Ontario department of mines, the Eldorado company does not produce a real talc, but an altered siliceous magnesian limestone. A dark gray talc, called "gratalc," is ground in a separate mill. The writer was permitted by the Gillespie company to inspect its mine and mill in June, 1920, and to study the methods employed as compared with methods used in the United States. The following description is based on his observations, supplemented by data supplied by the company:

**MINING.**

The mine and mill are at Madoc, on the Grand Trunk Railroad, the mill being on a siding opposite the station, and the mine about 2 miles distant. The mine, known locally as the Henderson mine, has been worked a number of years by different companies, but only under the present company has its operation been particularly successful. The early work was all open-pit mining, but at present all the talc is being removed by underground mining beneath the bottom of the old cut. The deposit seems to have the shape of a flattened inverted canoe and dips steeply to the south. It is underlain and overlain by crystalline gneisses and schists, and is intimately associated with dolomite, from which the talc was probably derived. The talc is white and crystalline, ranging from very soft to medium hard. Dolomite and calcite are common impurities; feldspar, quartz, and pyrite are present in places.

On each flank of the "canoe" vertical shafts have been sunk in the ore. The east shaft is now used for hoisting, but a new vertical shaft is being sunk in the footwall near the middle of the bow. The present haulage level is at 200 feet, but the new shaft will develop a new level at 300 feet. The vein is 15 feet to 70 feet thick, averaging 35 feet; from wall to wall it is good grinding stock, and no waste is made except in development. The workings are 700 to 800 feet long, but the vein probably extends at least twice this length within the boundaries of the property.

The method of mining in use does not follow exactly the one that will be used when the new shaft is complete, as previous operators had developed the mine; but the differences are of minor importance, and the ideal method will be described. From the new shaft a crosscut will be driven to the vein and 6 by 6 foot drifts run along the footwall outlining the ore body (fig. 22). At intervals of about 20 feet along the drift raises are put up, usually on the hanging wall side. A horizontal pillar is left to protect the drift, and the raises are widened into stopes the full width of the vein. Timbered ore chutes are provided at each raise, and additional manway raises are cut where needed to give access to the stopes. Only enough ore is drawn from the chutes to keep the broken ore in the stopes close enough to the ore in place to make drilling easy. Overhand stoping is continued upward until a timber mat which was laid down in the bottom of the open cut above is encountered. The stope is then

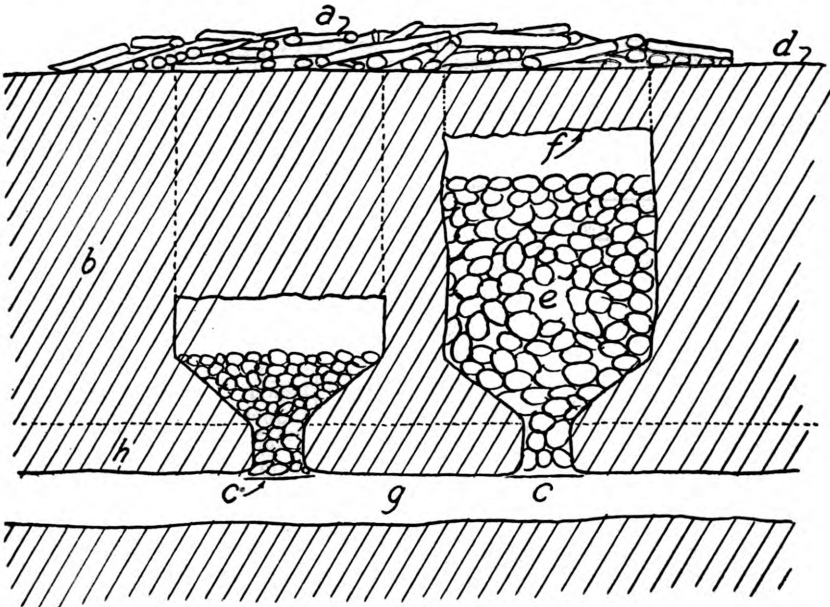

FIGURE 22.—Sketch of vertical section along drift in mine of George H. Gillespie Co., Madoc, Ontario: *a*, Timber mat; *b*, ore in place; *c*, chutes; *d*, bottom of open cut; *e*, broken ore; *f*, working face; *g*, drift; *h*, drift pillar.

considered finished and is allowed to remain full of broken ore. When the ore is needed it may be readily drawn off through the chutes and the drawing continued until surface waste appears. The drift pillars keep the drift open even after all the ore is drawn and the stopes are filled with waste. It is claimed that by this method when the stopes are full of ore a production of 100 tons per 10-hour day can be maintained with only five men—four underground and a hoist man at the top.

This method of mining has many advantages. All ore is broken by overhand stoping; many working places are available; few men underground are required, as no shoveling is necessary; no timber is needed in stopes; large storage for broken ore is available at no cost; and the ore is not likely to be water soaked, as the stopes drain themselves. The chief disadvantage is that ore may arch or hang up in the chutes, but usually such jams may be broken by shooting with dynamite. This method of mining, known in metal mines as

“shrinkage stoping,” is excellent for veins of moderate width that have strong, well-defined walls.

From the chutes the ore is drawn into one-half or two-third ton, 18-inch gage, steel cars, trammed by hand to the shaft, and dumped directly into the skip. The shafts are well timbered and divided by lagging into a skipway and a ladderway. In the latter, sollars or landing platforms are placed every 15 to 20 feet vertically. The drifts require some timber, but in general need no lagging. Drainage is taken care of by a small three-stage electrically driven centrifugal pump. Most of the drilling is done with small compressed-air

drills of the jack-hammer type.

At the surface the skips dump automatically into a bin provided with several loading chutes, from which wagons or trucks are loaded. In the power house are a double-drum hoist, geared to a 15-horsepower, 220-volt, alternating-current motor and a 10 by 12 inch single-stage air compressor belted to a 40-horsepower, 220-volt, alternating-current motor. The total installed horsepower at the mine is 70, but the load ordinarily carried is much less. Production is now about 50 tons per eight-hour day, and the capacity under present conditions is about 80 tons. When the new shaft is completed the capacity will be 100 tons per eight-hour day.

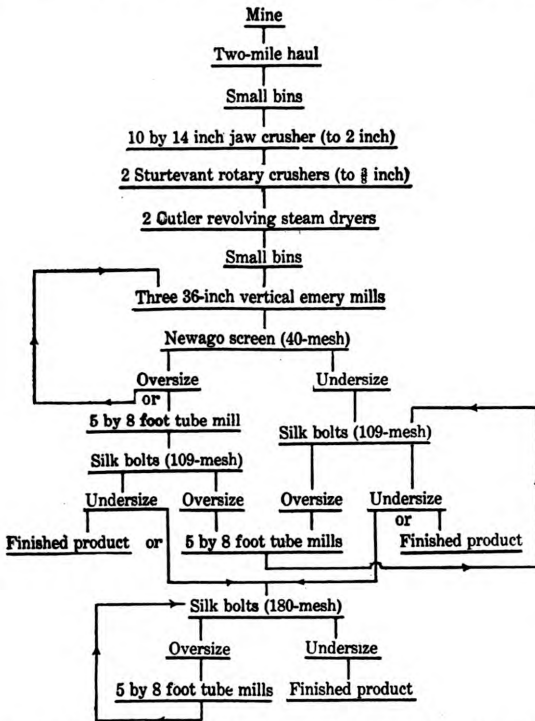

FIGURE 23.—Flow sheet of mill of George H. Gillespie & Co., Madoc, Ontario. Capacity, 50 tons per 22-hour day.

**MILLING.**

Ore from the mine is hauled, on contract, about 2 miles to the mill. As the mill has grown to its present size by successive stages, its present arrangement is not ideal, but the efficiency of the milling process is high.

Ore from the mine is dumped into a small bin, from which it is drawn off and fed by hand into the crusher. The progress of the ore through the mill is indicated approximately in the flow sheet (Fig. 23), in which elevators or conveyors are not shown. The dryers used are of the Cutler type, for use originally as corn dryers. Essentially they consist of a bundle of steam-heated pipes set in circular headers which are revolved mechanically about an axis nearly horizontal. The talc enters at one end and cascades around and between the hot pipes until it reaches the other end. The drying temperature may be regulated very closely, thus guarding against overheating, and there is no soot or ashes to contaminate the product. The dried talc is conveyed

Generated at University of Michigan on 2023-02-13 11:27 GMT / https://hdl.handle.net/2027/uhug.30112104112039  
 Public Domain, Google-digitized / http://www.hathitrust.org/access\_use#pd-google

some distance in the open air before it is fed to the next machine, to permit evaporation of moisture driven from the pores of the rock.

In the United States the bolting of talc through silk cloth is often held to be obsolete owing to its slowness and excessive cost. This mill demonstrates that bolting can be done efficiently and economically if proper precautions are taken, such as (1) careful sizing before bolting; (2) utilization of a large number of bolts; (3) no overloading of bolts; and (4) intelligent and careful supervision. Another feature of this mill is the use of short (5 by 8 foot) continuous-feed and discharge-tube mills, instead of the intermittent-dump cylinders or the long (6 by 24 foot) continuous-tube mills used in other parts of the country. Furthermore, the tube mills are used singly in closed circuit with bolts, instead of three or four in tandem. This close and careful sizing not only produces a uniform product but cuts down greatly the power consumption.

Three grades of ground talc are ordinarily made, based on color and grain size. The most important consumers are the toilet powder, textile, and soap industries. The present mill capacity is about 50 tons per 22-hour day, for the production of which about 140 horsepower is used. The erection of a new 100-ton mill with the present system of milling is contemplated.

The mine of the Anglo-American Talc Co. is near that of the George H. Gillespie Co. (Ltd.), and is said to be on the same vein. No opportunity of visiting the mine and mill was afforded, but the system of milling is said to resemble that used in the Gouverneur district of New York State.

### TALC IN BRITISH SOUTH AFRICA.

Talc and soapstone have been utilized in South Africa for generations. Soapstone images and carvings have been found in the ancient ruins of Southern Rhodesia, and the natives of the northern Transvaal still use quaintly carved soapstone bowls for evaporating brine in making salt; but the industrial uses have been developed only within the last few years. Talc—massive, fibrous, and foliated—has been reported in many districts, but only four are important at present. Two of these, the Barberton district and the Krugersdorf district, are in the Transvaal, the third is in Zululand, and the fourth in Southern Rhodesia. The most important district is the Barberton, though very good foliated talc is found in Southern Rhodesia. The talc reserves in the Barberton district are enormous, but in 1920 there were only three producing companies, the Scotia Talc Mine (Ltd.), Joe's Luck, Barberton, Transvaal; the Verdite Mine, Jamestown, Barberton, Transvaal; and B. R. Berrett, Greytown, Natal. Of these the first has a capacity of 2,000 tons crude talc or 1,000 tons ground talc per month, and the second 200 tons ground talc per month. The shipping port for the Scotia mine is Delagao Bay, 120 miles from the mine. Though the total talc production of South Africa was only 757 tons in 1919, plus a few hundred tons (412 tons in 1917) of manufactured talc goods, the industry seems to have great possibilities both for domestic use and for export.

## THE VERDITE MINE.

The Verdite mine, the largest single producer, is 3 miles northwest of Noordkaap station, on the Barberton Railway in the Transvaal. Here the country rock, dark gray or green crystalline schist, contains numerous nearly vertical beds or bands of talc, varying from a few inches to 15 feet in width, bounded by smooth joint planes. These joint planes contain thin plates or scales of gold, and the deposit was originally opened as a gold mine. The talc ranges from pale green, fibrous and semitranslucent, to dark green and opaque. Most of the gold is contained in the more highly colored talc, which is sorted out as a separate grade and milled by a different process. Ore reserves are said to be large.

The mine is opened by two shafts and numerous drifts, and the talc is removed by ordinary underground methods. The best grade is first crushed to a small size and then passed through a cyclone disintegrator, set for fine grinding. The finely pulverized material is forced upward by a current of air from a fan attached to the disintegrator, through a pipe to a large vertical canvas tube, in which it is collected for bagging. The coarser material, lifted only part way up the vertical pipe, is caught by deflecting wings and diverted to a horizontal silk bolting screen. The screen oversize is reground, and the undersize is sold as a lower grade product.

It should be noted that this system of grinding and separation somewhat resembles the Raymond system used in Vermont and elsewhere, but is less efficient as there is no separating tank between the grinder and the dust collector, and the coarse material must be periodically returned by hand for regrinding. The dark green talc, containing gold, goes to an ordinary five-stamp gold mill, the gold being recovered as amalgam on the plates, and the tailing going to a Wilfley table that separates coarse gold and impurities. The tailing from the tables is dried, screened, and sold as a cheap grade of talc.

A portion of the talc is massive and is cut into lava blanks, crayons, and engineers' pencils, the latter being used in large quantities by the South African railways. The uses of the various grades of talc are tabulated below:

*First quality ground.*—Toilet and medical purposes.

*Second quality ground (screen product).*—Cleaning and drying cereals, soap and grease manufacture, foundry facings, veterinary surgery.

*Third quality ground (table tailings).*—Boot manufacture, leather dressing and finishing, paints, for distempers, by garages and rubber manufacturers, as a preservative for eggs and fruit, artificial stone and tiles.

*Massive.*—Lava blanks, slate pencils, engineers' pencils.

The 1917 production of the Verdite mine was 715 tons of crude talc, valued at about \$9,800, and 412 tons of manufactured talc, valued at about \$17,400. This constituted practically the entire production of talc in British South Africa in 1917. At present, however, the Buffalo Asbestos Co., and the African Asbestos Co. are producing talc on a commercial scale, although probably of a lower grade.

## PUBLICATIONS ON NONMETALLIC MINERAL TECHNOLOGY.

A limited supply of the following publications of the Bureau of Mines has been printed and is available for free distribution until the edition is exhausted. Requests for all publications can not be granted, and to insure equitable distribution applicants are requested

to limit their selection to publications that may be of especial interest to them. Requests for publications should be addressed to the Director, Bureau of Mines.

The Bureau of Mines issues a list showing all the publications available for free distribution as well as those obtainable only from the Superintendent of Documents, Government Printing Office, on payment of the price of printing. Interested persons should apply to the Director, Bureau of Mines, for a copy of the latest list.

PUBLICATIONS AVAILABLE FOR FREE DISTRIBUTION.

**BULLETIN 112.** Mining and preparing domestic graphite for crucible use, by G. D. Dub and F. G. Moses. 1920. 80 pp., 5 pls., 20 figs.

**BULLETIN 124.** Sandstone quarrying in the United States, by Oliver Bowles. 1917. 143 pp., 6 pls., 19 figs.

**TECHNICAL PAPER 111.** Safety in stone quarrying, by Oliver Bowles. 1915. 48 pp., 5 pls., 4 figs.

**TECHNICAL PAPER 126.** The casting of clay wares, by T. G. McDougal. 1916. 26 pp., 6 figs.

PUBLICATIONS THAT MAY BE OBTAINED ONLY THROUGH THE SUPERINTENDENT OF DOCUMENTS.

**BULLETIN 71.** Fullers' earth, by C. L. Parsons. 1913. 38 pp. 5 cents.

**BULLETIN 92.** Feldspars of the New England and Northern Appalachian States, by A. S. Watts. 1916. 181 pp., 8 pls., 22 figs. 25 cents.

**BULLETIN 95.** Glossary of mining terms, by A. H. Fay. 1919. 754 pp. 75 cents.

**BULLETIN 146.** Technology of salt making in the United States, by W. C. Phalen. 1917. 144 pp., 24 pls., 10 figs. 25 cents.

**BULLETIN 106.** The technology of marble quarrying, by Oliver Bowles. 1916. 174 pp., 12 pls., 33 figs. 30 cents.

**BULLETIN 128.** Refining and utilization of Georgia kaolins, by I. E. Sproat. 1916. 55 pp., 5 pls., 11 figs. 15 cents.

**BULLETIN 160.** Rock quarrying for cement manufacture, by Oliver Bowles. 1918. 160 pp., 6 pls., 31 figs. 25 cents.

**BULLETIN 184.** The manufacture of sulphuric acid in the United States, by A. E. Wells and D. E. Fogg. 1920. 216 pp., 13 pls., 36 figs. 40 cents.

**TECHNICAL PAPER 155.** Gypsum products, their manufacture and uses, by R. W. Stone. 1917. 67 pp., 9 pls., 10 figs. 20 cents.

**TECHNICAL PAPER 233.** Properties of some stoneware clays, by H. G. Schuricht. 1920. 42 pp., 1 pl., 23 figs. 10 cents.





A.		Page.
Absorbent power, ground talc, im- portance of-----		85
Adits, driving of-----		19
Aerial tramway, for mine to mill haulage, use of-----		29
Agalmatolite, characteristics of----		1
Air separation, removing impuri- ties by-----		55
theory of-----		54
fine, method for-----		53
Air-separation systems, discussion of-----	52-57	
Alabama, talc deposits in-----		9
American Mineral Co., belt conveyor of, view of-----		30
mining and milling methods of_	98-100	
shaft houses of, view of-----		99
tunneling method of, view of_		98
Analyses, talc-----		2
Anglo-American Talc Co., mention of-----		125
Arkansas, talc deposits in-----		9
Asbestine, definition of-----		78
Austria, talc deposits in-----		10
talc production of-----		7
utilization of talc in-----		6, 7
B.		
Bagging, methods for, discussion of_		59
Bagging machines, merits and disad- vantages of-----		59
valve type, view of-----		53
Bags, for packing talc, sizes and kinds used-----		60
Baker, H. C., acknowledgment to_		111
Belt conveyors, use of-----		36
views of-----		30
Biltmore, N. C., talc mines and mill at-----		121
Biltmore Talc Co., flow sheet of mill of-----		120
mining and milling methods of_		121
Bins, discharge spout for, view of_		30
for storing finished talc, ad- vantages of-----		50
freezing of ore in, prevention of_		37
storage of crude ore in-----	28, 36	
Blasting. <i>See</i> Shooting.		
Bolting, talc through silk cloth, pre- cautions for-----		125
Bolting reels, use of-----		51
Bowles, O., work cited-----		18
Brazil, talc deposits in-----		11
British India, talc for lava from_		81
British South Africa, talc, deposits in-----		11, 125
mine in-----		126
production of-----		7, 125
use of talc products in-----		126

	Page.
Brunton, D. W., and Davis, A. J., work cited-----	22
Buhr mill, use of-----	44
view of-----	44

### C.

California, mining and milling prob- lems in-----	114
talc, deposits in-----	113
production in-----	8, 9, 13, 112
talc mines and mills in, descrip- tions of-----	114-117
Canada, talc, deposits in-----	10
production of-----	7
utilization of-----	6, 7
<i>See also</i> Madoc, Ontario.	
Carbide lamps for quarrymen, use of_	26
Carbola Chemical Co. <i>See</i> St. Law- rence Talc Co.	
Ceramic materials, costs of, compari- son of-----	76
Chatsworth, Ga., flow sheet of mill at-----	120, 121
Chattanooga Talc Co., flow sheets of mills of-----	120, 121
Chester, Vt., talc mine and mill at_	91
China, talc deposits in-----	11
Clay, retention tests of, results of_	71
Cohutta Talc Co., flow sheet of mill of-----	121
Colombia, talc deposits in-----	12
Color, ground talc, determination of_	84
Composition lava, manufacture of_	81
<i>See also</i> Lava.	
Conveyors, use of-----	62, 63
Cost accounting, importance of-----	16
Costs, talc mills, discussion of-----	34
Crayon stock. <i>See</i> Pencil stock.	
Crosscuts, driving of-----	20
Crusher. <i>See</i> Rotary crusher.	
Crushing, coarse, methods of-----	41
secondary, discussion of-----	42

### D.

Death Valley Junction, Calif., talc mines and mills near---	116
Diamond drill, use in prospecting---	17
Diller, J. S., on derivation of talc---	4-6
on trade names for talc-----	79
work cited-----	102
Diller, J. S., Fairchild, J. G., and Larsen, E. S., work cited-----	81, 111
Disintegrators, use of-----	42, 43, 45
D. M. Steward Co., flow sheet of talc mill of-----	121
need for-----	25
Drainage, at talc mines, method for_	103
Drifts, construction of-----	19
Drilling methods, discussion of-----	22-23

	Page.		Page.
Dryer, mechanical, use of, factors governing-----	40	Gouverneur, N. Y., talc mines and mills at-----	106, 108
Drying wet fines, methods of-----	38-41	Grain shape, ground talc, determination of-----	83
Dump cylinder, intermittent, description of-----	47	Grain size, ground talc, determination of-----	82
E.			
East Granville, Vt., talc mine and mill at-----	95	Great Britain, talc deposits in-----	12
Eastern Talc Co., flow sheet of mill of-----	94	Grinding, talc, efficiency in, need of fine, factors governing-----	32 44
mill and incline plane from mine, view of-----	31	See also Wet grinding.	
mining and milling methods of truck and car for incline cableway, view of-----	93-95 31	Grit, ground talc, determination of-----	85
Electricity, use in mining plants-----	29	Grizzlies, use of-----	50
Elevators, use in mills-----	62, 63	Ground talc, process for-----	15
Emerick air separator, cross section of-----	56	specific gravity of, factors governing-----	33
description of-----	55	uses of, list of-----	3, 66-69
range of use of-----	57	H.	
Exhaust fan, Raymond mill, view of-----	52	Hammer mills, use of-----	42, 43, 45
Explosives, for blasting-----	23	view of-----	43
F.			
Fillers, use of talc for-----	14	Hardinge mill, description of-----	50
Flow sheets, talc mill-----	58, 92, 94, 97, 104, 105, 107-110, 115, 116, 119-121, 124	Hardinge, Harlowe, on disadvantages of long tube mill-----	48
Foliated Talc Co., flow sheet of mill of-----	110	Hardness, ground talc, determination of-----	83
mining and milling methods of-----	110-111	Haulage, crude and bagged talc, precautions for-----	62
Formulas, lime plasters, use of talc in-----	80	methods of-----	24, 27, 29-31
France, soapstone, deposits in-----	10	mine to mill, track and cars for, views of-----	30, 31
talc, deposits in-----	9	Heat, behavior of talc under, discussion of-----	86
production of-----	7	Heckel, G. B., on use of inert pigment in paint-----	78
use for lava from-----	81	on use of Pamak-----	79
Freezing. See Bins.		Hoisting, discussion of-----	24
Fuller-Lehigh mill, description of-----	47	I.	
view of-----	45	Impact screens, use of-----	51
G.			
Gardner, H. A., on properties of talc used in paints-----	77	See also Newago screen; Tyler Hummer screen.	
Gas tips, use of "lava" for-----	81	Impurities, removal of-----	63
Georgia, talc, occurrence of-----	117	India, talc, deposits in-----	11
production in-----	9	production of-----	7
talc mines and mills in-----	117, 120, 121	Insulation, use of "lava" for-----	81
Georgia Talc Co., flow sheet of mill of-----	120	International Talc Co. See Foliated Talc Co.	
George H. Gillespie & Co., flow sheet of mill of-----	124	International Pulp Co., flow sheets of mills of-----	107, 108
mining and milling methods of-----	122-125	mining and milling methods of-----	106-108
stoping methods of-----	21	Inyo Talc Co., flow sheet of mill of-----	115
talc mine, vertical section along drift of-----	123	mill of, view of-----	98
Germany, talc, deposits in-----	11	mining and milling methods of-----	114-115
production of-----	7	Italy, talc, deposits in-----	10
utilization of-----	6, 7	production of-----	7
use for lava-----	81	use for lava from-----	81
Glendon, N. C., talc mine and mill at-----	118	J.	
		Jacobs, E. C., work cited-----	91
		Japan, talc deposits in-----	12
		Johnson, Vt., talc mine and mill at-----	98
		K.	
		Kanashima, S., work cited-----	75
		Kanowitz, S. B., on Raymond air-separation system-----	52

	Page.	P.	Page.
Keeler, Calif., talc mine and mill at	114		
Keith, A., work cited	6		
L.			
Lamps. <i>See</i> Carbide lamps.			
"Lava," definition of	80		
manufacture of	81		
properties of	80		
talc suitable for making	81		
uses of	3		
M.			
Madoc, Ontario, talc production in	122		
Magnesia Talc Co., belt conveyor and feed spout of, view of	30		
flow sheet of mill of	97		
mine cars used at, view of	30		
mining and milling methods of	95-98		
Magnetic pulleys, use of	63		
Maps, underground and surface, im- portance of	27		
Maryland, talc, deposits in	9		
Massachusetts, talc, deposits in	9		
occurrence of	109		
talc mine and mill in	110		
Merrill, G. P., on characteristics of soapstone	1		
Milling costs, importance of	14		
Milling methods, factors governing	32-35		
importance of	15		
Mills. <i>See</i> States named.			
Mine cars, for hauling crude talc, view of	30		
Mine telephones, use of	25		
Mines. <i>See</i> States named.			
Mining plant, equipment for	28		
Montana, talc deposits in	9		
N.			
Natural Bridge, N. Y., talc mine and mill at	102		
Newago screen, view of	44		
New Hampshire, soapstone deposits in	9		
Newland, D. H., on occurrence of talc in the Gouverneur dis- trict	101		
work cited	4, 100		
New Jersey, talc deposits in	9		
New York, mines and mills in, de- scription of	100-109		
talc, deposits in	4, 5		
occurrence of	100		
production in	8		
talc mining in, statistics on	100		
North Carolina, talc, occurrence of	117		
production in	8, 9		
talc mines and mills in	117-121		
Norway, talc, deposits in	12		
production of	7		
O.			
Ontario. <i>See</i> Madoc, Ontario.			
Opacifying agents, formulas for	80		
Ore feeders, use of	63		
		Pacific Coast Talc Co., flow sheet of mill of	116
		98	
		115	
		116	
		78	
		77	
		78	
		76	
		77	
		77	
		79	
		73	
		72	
		13, 71-74	
		74	
		75	
		30	
		65	
		65	
		65	
		64	
		64	
		9	
		6	
		12	
		82-86	
		113	
		74-76	
		33	
		111	
		118	
		18	
		43, 45	
		43	
		26	
		1	
R.			
		20	
		52-55	
		45, 52	
		31	
		52	
		45	
		46	
		46	
		53	
		52	
		1	
		71-72	
		62	
		9	

	Page.		Page.
Rochester, Vt., talc mines and mill at -----	93	Talc deposits, distribution -----	6, 7
Rock house, talc mill, view of -----	99	prospecting and development of -----	17
Rosin, talc as substitute for, use of -----	73	workable, size of -----	15
Rotary crusher, view of -----	45	Talc milling, history of -----	31
Rowe, Mass., talc mine and mill at -----	110	Talc mills, design and location, importance of -----	35
Royalties, on talc deposits -----	16-17	Southern, problems of -----	118
S.		Talc mine, open cut at, view of -----	99
Safety precautions, talc mines -----	23, 25	vertical section along drift, figure showing -----	123
St. Lawrence Talc Co., flow sheet at mill of -----	104	Talc mining, limitations on -----	15
mining and milling methods of -----	102-104	methods of -----	19, 20-22
Scandinavia, use of talc for paper making in -----	73	Talc packers, use of -----	59
Schnurpfell, —, work cited -----	80	view of -----	58, 59
Screens. <i>See</i> Bolting reels; Grizzlies; Impact screens; Trommels; Vibrated screens.		Talc Products Co., Calif., mention of -----	116
Screen tests, commercial talc, results of -----	88	Talc Products Co., N. C., flow sheet of mill of -----	119
Shaft, talc mine, discussion of -----	19	mining and milling methods of -----	118-120
view of -----	114	open cut of, view of -----	99
Shaft houses, view of -----	99	Talcville, N. Y., mine and mill at -----	104
Shooting, methods of -----	23	Tennessee, talc mills in -----	117, 120, 121
Shrinkage stoping, advantages of -----	22	Throw-out, for pulverizer, advantages of -----	43
Signal system, importance of -----	25	view of -----	31
Silver Lake, Calif., talc mine and mill at -----	115	Toilet powder, talc for, requirements for -----	112
Skips, for hauling crude talc, view of -----	30	Tramways, aerial, to mills -----	29
<i>See</i> Hoisting.		Transportation. <i>See</i> Haulage.	
Slip, need for method of testing -----	84	Transportation costs, importance of -----	13
Smyth, C. H., jr., work cited -----	4, 5, 100	Tremolite, derivation of talc from -----	5
Soapstone, ancient use of -----	125	Trommels, use of -----	50
characteristics -----	1	Tube mill, amount ground at different points in, curve showing -----	49
deposits, distribution -----	6, 7	descriptions of -----	47-50
grades of -----	8	long and short, comparison of -----	48
massive, uses of, list of -----	3, 69	Tunneling method, talc mine, view of -----	98
powdered, uses of, list of -----	3, 66	Tyler Hummer screen, view of -----	45
Sorting, crude talc, methods of -----	36	U.	
Spain, talc, deposits in -----	10	Uniform Fibrous Talc Co., flow sheet of mill of -----	105
production of -----	7	mine to mill handling of crude at, view of -----	30
Specific gravity, ground talc, determination of -----	84	mining and milling methods of -----	104-106
Steatite, ancient uses of -----	2	United States, manufacture of soapstone in -----	6, 7
characteristics -----	1	talc production of -----	7, 8
Stoping, methods of, discussion of -----	20-22	utilization of talc in -----	6, 7
Storage, of talc, methods of -----	61	<i>See also</i> States named.	
<i>See also</i> Bins.		Unloading, crude talc, methods of -----	35
T.		V.	
Talc, characteristics -----	1, 33	Vacuum separator, description of -----	53
chemical composition of -----	96	view of -----	53
domestic, quality of -----	112	Veatch, O., work cited -----	6
exports of -----	112	Ventilation, in talc mines -----	26
grades of -----	8, 87, 89	Verdite mine, talc mining and milling methods at -----	126
imports of -----	112	Vermont, soapstone, industry in -----	89
massive, uses of, list of -----	3, 69	mines and mills in, location of -----	90
origin and occurrence -----	4	sold, in, grades of -----	91
powdered, uses of, list of -----	3, 66		
production, United States -----	13		
properties of -----	71		
retention tests of, results of -----	71		
specific gravity of -----	33		
trade names for -----	79		

	Page.	W.		Page.
Vermont, talc industry in-----	89		Washington, talc deposits in-----	9
talc, mines and mills in, de-			Waterbury, Vt., talc mine and mill	
scriptions of-----	91-100		at-----	95
location of-----	90		Wedge-cut drilling, advantages of---	22
mode of occurrence-----	90		Wet fines, handling of-----	40
production in-----	8		Wet grinding, advantages of-----	58
grades sold in-----	91		difficulties of-----	57
Vermont Talc Co., flow sheet of			W. H. Loomis Talc Corporation,	
mill of-----	92		flow sheet of mill of-----	109
mining and milling methods of	91-92		mining and milling, methods	
Vertical emery mill, use of-----	45		of-----	108-109
view of-----	44		rock house of, view of-----	99
Vibrated screens, use of-----	51		Wyoming, talc deposits in-----	9
Virginia, soapstone production in---	117			
talc production in-----	8			



1	W	W
2	W	W
3	W	W
4	W	W
5	W	W
6	W	W
7	W	W
8	W	W
9	W	W
10	W	W
11	W	W
12	W	W
13	W	W
14	W	W
15	W	W
16	W	W
17	W	W
18	W	W
19	W	W
20	W	W
21	W	W
22	W	W
23	W	W
24	W	W
25	W	W
26	W	W
27	W	W
28	W	W
29	W	W
30	W	W
31	W	W
32	W	W
33	W	W
34	W	W
35	W	W
36	W	W
37	W	W
38	W	W
39	W	W
40	W	W
41	W	W
42	W	W
43	W	W
44	W	W
45	W	W
46	W	W
47	W	W
48	W	W
49	W	W
50	W	W
51	W	W
52	W	W
53	W	W
54	W	W
55	W	W
56	W	W
57	W	W
58	W	W
59	W	W
60	W	W
61	W	W
62	W	W
63	W	W
64	W	W
65	W	W
66	W	W
67	W	W
68	W	W
69	W	W
70	W	W
71	W	W
72	W	W
73	W	W
74	W	W
75	W	W
76	W	W
77	W	W
78	W	W
79	W	W
80	W	W
81	W	W
82	W	W
83	W	W
84	W	W
85	W	W
86	W	W
87	W	W
88	W	W
89	W	W
90	W	W
91	W	W
92	W	W
93	W	W
94	W	W
95	W	W
96	W	W
97	W	W
98	W	W
99	W	W
100	W	W